

yardmaster

INTERNATIONAL

1209 All

Please direct enquires to:

Yardmaster International
Cahore Road
Draperstown
BT45 7AP.
Tel: 028 796 28449

Demandes de renseignements à:

TRIGANO JARDIN
Service Commercial
Usine du Boulay
41 170 Cormenon
Mondoubleau
Tel: (02) 54 73 55 55

Bitte alle Anfragen an:

I.N.I.
Kaistraße 7-9
40221 Düsseldorf
TEL: 021130212815



GREEN VERT GRUN

MODEL 1012 SL

Assembly Instructions

Instructions D'assemblage Abris en Métal

Opbouwbeschrijving Metalen Bergingen

Montageanweisungen Metallgerätekäuser

Instrucciones De Montaje

Instruções De Montagem Abrigo Metálico

PARTS LIST	LISTE DE PIÈCES	PART NO.	MODEL & QTY		LENGTH
PART DESCRIPTION	DESCRIPTION DE LA PIÈCE		1012	MM	
Side Wall Panel	Panneau Mural	101.17	12	1770	
Back Wall Panel	Panneau Mural	101.13	6	1370	
Front wall Panel	Panneau Mural	101.07	6	720	
Corner Post	Montant d'Angle	103.06	4	1825	
Corner Post Cap	Chape de montant d'Angle	103.07	4	1825	
Intermediate Post	Montant intermediaire	103.08	3	1825	
Vertical Brace	Attache verticale	103.09	10	1823	
Intermediate Post Cap	Chape de Montant intermediaire	103.13	3	1825	
Door Post Cap	Chape de Montant de Porte	106.04	2	1825	
Door Post	Montant De Porte	106.05	2	1825	
Inter-Roof Panel	Panneau Toit (Milieu)	201.3	8	1520	
Translucent Roof Panel	Fenetre Toit	205.3	2	1520	
L/H Front-R/H Rear Roof	Panneau Toit Avant Gauche/Arrière	203.29	2	1520	
R/H Front-L/H Rear Roof	Panneau Toit Avant Droite/Arrière	204.29	2	1520	
Left Hand Gable	Pignon Gauche	301	2	920	
Right Hand Gable	Pignon Droite	302	2	920	
Centre Gable	Pignons Centraux	305.3	2	995	
Base Rail	Rail Base	401.22	2	2033	
Base Rail	Rail Base	401.2	3	1833	
Base Rail	Rail Base	401.14	1	1233	
Corner Gusset	Gousset D'angle	406	4	86	
Corner Gusset Stiffner	Renfort De Gousset D'angle	407	4	150	
Front Anchor Bracket	Bride d'angle devant	407EA	2	69	
Left/Right Hand Door Guide	Guide De Porte Gauche/Droite	408409.3 EA	2	933	
Side Beam	Poutre Latérale	501.2	2	1833	
Side Beam	Poutre Latérale	501.22	2	2033	
Roof Beam	Poutre Toit	502.2	6	1834	
Roof Beam	Poutre Toit	502.22	6	2034	
Ridge Cover	Faîtière	503.02	4	615	
Ridge Cover	Faîtière	503.03	1	415	
Ridge Cover	Faîtière	503.07	2	490	
Gutter	Gouttière	504.17	2	1744	
Gutter	Gouttière	504.19	2	1944	
L/H Roof Beam Gusset	Gousset De Poutre Faîtière Gauche	505	2	145	
R/H Roof Beam Gusset	Gousset De Poutre Faîtière Droite	506	2	145	
Roof Beam Support	Soutien De Poutre Toit	506.3	4	230	
Ridge Cover Cap	Chape Faîtière	507	2	160	
Left Hand Gutter End Cap	Embout D'extrémité De Gouttière	508	2	45	
Right Hand Gutter End Cap	Embout D'extrémité De Gouttière	509	2	45	
Left Hand Door	Porte Gauche	601	1	1816	
Right Hand Door	Porte Droite	602	1	1816	
Door Track	Glissière De Porte	603.63	2	1390	
Gable Brace	Glissière De Pignon	603.18	4	1395	
Door Roller And Bracket	Galet Et Bride De Porte	6071	4	30	
Door Bracket	Bride De Porte	607EA	2	25	
Door Saddle	Bride De Porte	608.3 EA	1	1226	
Door Handle	Poignée	609 SL	2	100	
Door Pelmet	Faîtière De Porte	615.02	1	1264	
Door Brace	Porte Renforcee	620.3	6	640	

ONDERDELENLIJST	TEILE-LISTE		MENGE	LÄNGE	
BESCHRIJVING VAN DE	TEILE-BEZEICHNUNG	TEILNUMMER	1012	MM	
Zijwandpaneel	Seitewandplatten	101.17	12	1770	
Wandpaneel - achterkant	Hinterseitewandplatten	101.13	6	1370	
Wandpaneel - voorkant	Vorderseitewandplatten	101.07	6	720	
Hoekstijl	Eckpfosten	103.06	4	1825	
Hoekstijlplaat	Eckpfostenverkleidung	103.07	4	1825	
Mittenstijl	Mittelpfosten	103.08	3	1825	
Raamstijl	Vertikalstütze	103.09	10	1823	
Mittenstijlplaat	Mittelpfostenverkleidung	103.13	3	1825	
Deurstijlplaat	Türpfostenverkleidung	106.04	2	1825	
Deurstijl	Türpfosten	106.05	2	1825	
Dak-Tussenplaatl	Dach-Zwischenplatten	201.3	8	1520	
Doorziec	Dach-Oberlicht	205.3	2	1520	
Dakplaat Linksvoor/Rechtsachter	Dachplatten - Vorne Links Bzw. Hinten	203.29	2	1520	
Dakplaat Rechtssvoor/linksachter	Dachplatten - Vorne Rechts Bzw. Hinten	204.29	2	1520	
Smalle dak-tussenplaat	Schmale Dach-Zwischenplatten	202.3	2	1520	
Geveltop -	Giebel - Vorne Links Bzw. Hinten Rechts	301	2	920	
Geveltop -	Giebel - Vorne Rechts Bzw. Hinten Links	302	2	920	
Geveltoppen - Midden	Mittel-Giebel	305	2	995	
Funderingsrail	Grundleiste	401.22	2	2033	
Funderingsrail	Grundleiste	401.2	3	1833	
Funderingsrail	Grundleiste	401.14	1	1233	
Hoekinzetstuk	Hintere Eckenwinkel	406	4	86	
Versterking van Hoekinzetstuk	Eckenwinkelversteifung	407	4	150	
Verankering Steun	Eckenwinkelversteifungen	407EA	2	69	
Deurgeleider Links/Rechtsbuiten	Linke/Rechte äußere Türführung	408409.3 EA	2	933	
Zijbalk	Seitenträger	501.2	2	1833	
Zijbalk	Seitenträger	501.22	2	2033	
Dakbalk	Dachträger	502.2	6	1834	
Dakbalk	Dachträger	502.22	6	2034	
Nokplaat	Firstverkleidung	503.02	4	615	
Nokplaat	Firstverkleidung	503.03	1	415	
Nokplaat	Firstverkleidung	503.07	2	490	
Regengoot	Dachtraufeverkleidung	504.17	2	1744	
Regengoot	Dachtraufeverkleidung	504.19	2	1944	
Linkersteunplaat Nokbalk	Linke Firstträgerwinkel	505	2	145	
Rechtersteunplaat Nokbalk	Rechte Firstträgerwinkel	506	2	145	
Nokbalk Steun	Dachtragbalken	506.3	4	230	
NokplaatEindstuk	Firstverkleidungskappe	507	2	160	
Eindkap	Linke Dachrinnen-Endkappen	508	2	45	
Eindkap	Rechte Dachrinnen-Endkappen	509	2	45	
Linkerdeur	Linke Tür	601	1	1816	
Rechter deur	Rechte Tür	602	1	1816	
Deurrail	Türschiene	603.63	2	1390	
Geveltop-Klomp	Giebel-Vorne Balken	603.18	4	1395	
Deurglijder	Türschieber	6071	4	30	
Deurhoekstuk	Tür-Distanzschiebe	607EA	2	25	
Deurslede	Türschwelle	608.3 EA	1	1226	
Deurhendel	Türgriff	609	2	100	
Raambedekking	Verbindung Teil	615.02	1	1264	
Deurklomp	Türstütze	620.3	6	640	

WALL PANEL PANNEAU MURAL WANDPLATTEN WANDPANEEL

PAINEL DA PAREDE PANELES DE LA PARED

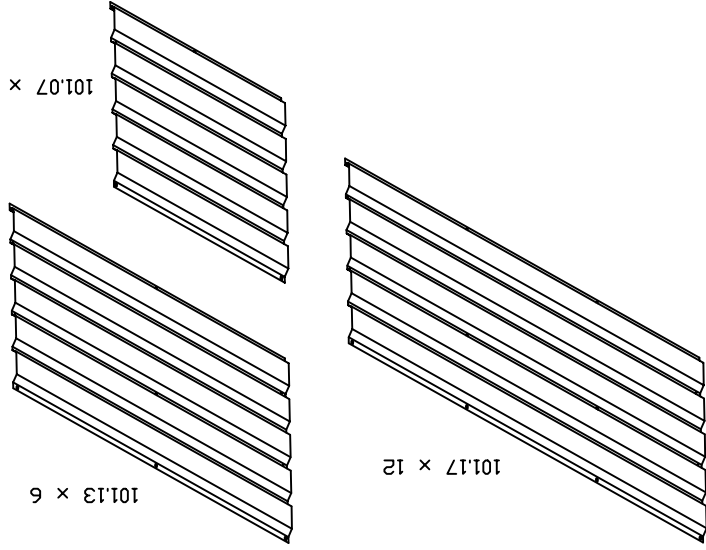

ROOF PANEL PANNEAU TOIT DACHPLATTE DAKPLAAT

PAINEL DO TELHADO PANELES DEL TEJADO

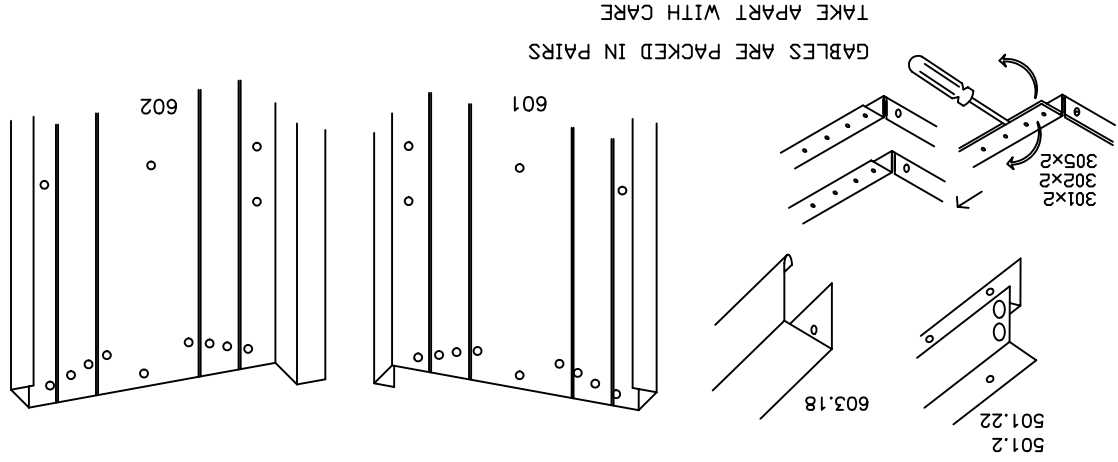
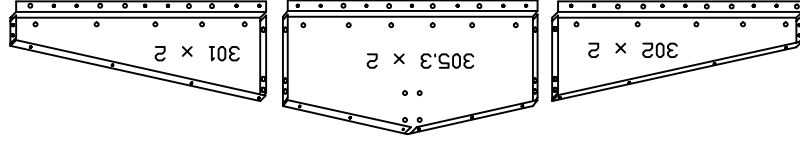
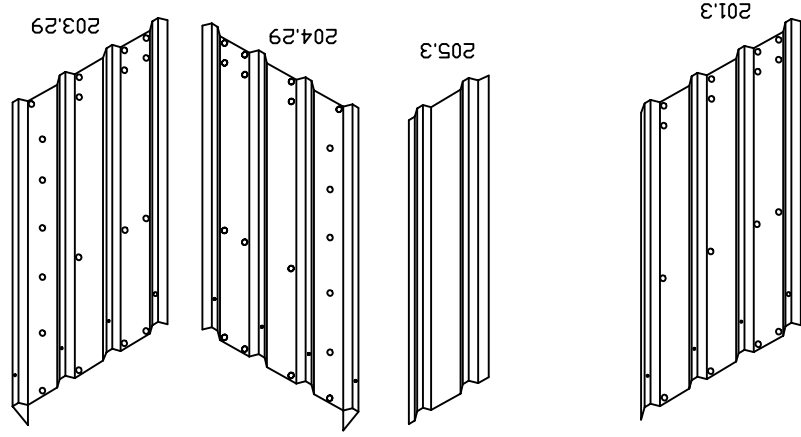

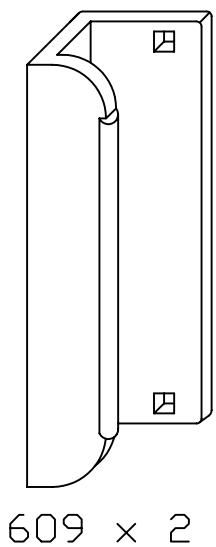

609 x 2

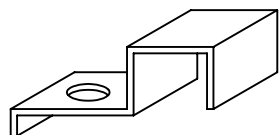

407EA x 4

406 x 4

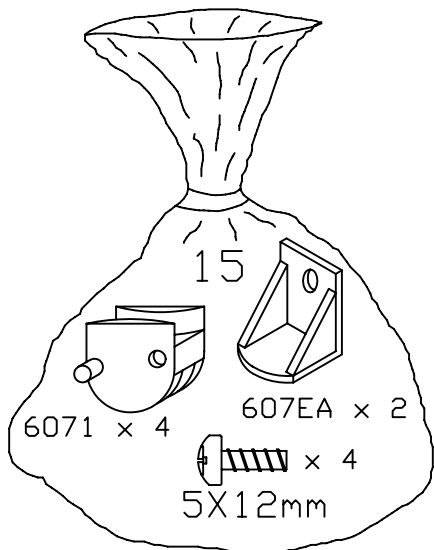
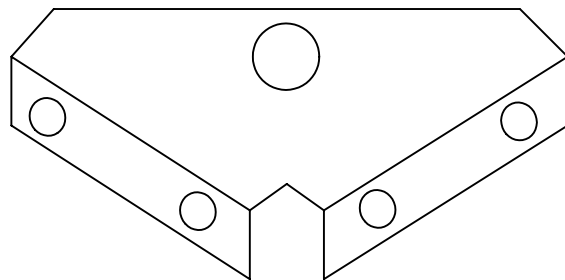

6071 x 4

607EA x 2

5X12mm x 4

5X12mm

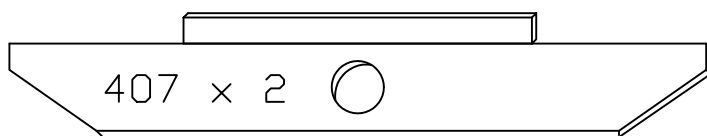

407 x 2

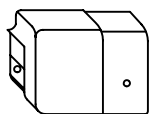

508 x 2

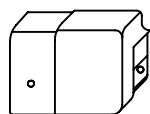

509 x 2



yardmaster

507 x 2

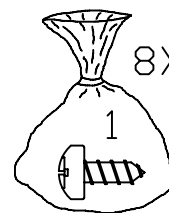

8X9mm

1

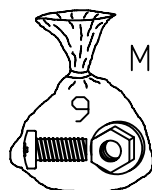

M5x12mm

9

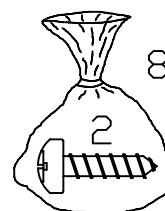

8X12mm

2

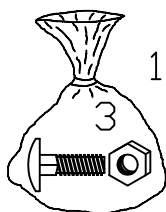

12X5mm

3

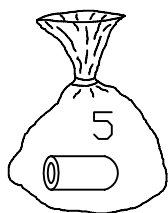

5

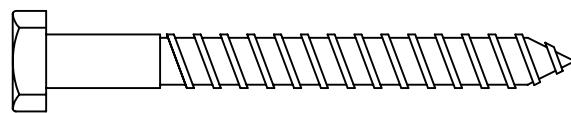

M8X70mm X 2



10

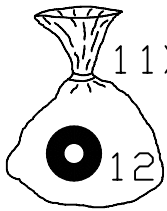

11X4mm

12

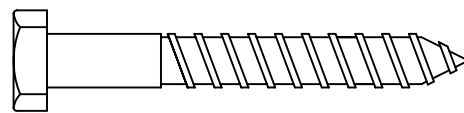

M8X50mm X 4

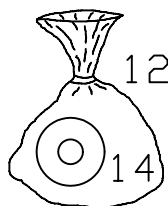

12X4mm

14

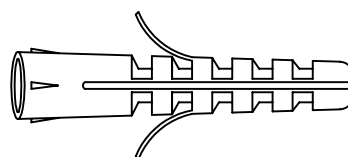

M10X50mm X 6

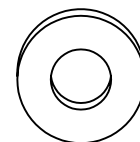

M8X19mm X 6

INSTRUCTIONS .

Before starting, read through the assembly instructions carefully. Check thoroughly all the parts you have received against the parts list (page 1,2) and the diagram (page 3,4). Ensure that no parts are damaged.

THINGS TO REMEMBER !

- 1. WEATHER WARNING ! DO NOT ERECT YOUR BUILDING ON A WINDY DAY. ANY BUILDING LEFT PARTIALLY CONSTRUCTED MAY BE SERIOUSLY DAMAGED (FIG.1).**
- 2. ALL ASSEMBLY OPERATIONS MUST TAKE PLACE ON A COMPLETELY LEVEL SURFACE (FIG. 1)**
- 3. UNLESS OTHERWISE STATED SCREWS AND FIBRE WASHERS (BAGS 1 AND 12) MUST BE USED IN ALL ASSEMBLY OPERATIONS.**
- 4. IT IS RECOMMENDED THAT YOU WEAR THE GLOVES PROVIDED WHEN ASSEMBLING THIS PRODUCT.**
- 5. THE SHED SHOULD BE SECURELY ANCHORED TO A FIRM LEVEL BASE E.G. CONCRETE, PAVING SLABS, WOOD ETC FOR CONCRETE BASE SEE BELOW.**

SITE PREPARATION CONCRETE.

1. Concrete should be laid a minimum of 75mm thick and at least 100mm greater than the overall size of the metal base frame at approx. 25mm above ground level. A sheet of heavy duty polythene placed under the base area will help prevent dampness rising from the ground into the shed. For concrete base measurements see fig. 2.

NOTICE DE MONTAGE .

Avant de commencer à lire attentivement la notice de montage, vérifiez précisément si vous avez bien reçu toutes les pièces énoncées sur la liste page 1,2 ainsi que sur le schéma page 3&4. Assurez vous qu'aucune pièce n'a été endommagée.

N'OUBLIEZ PAS !

- 1. TEMPÊTE DE VENT: NE JAMAIS MONTER VOTRE ABRI PAR GRAND VENT. NE PAS LAISSER UN ABRI PARTIELLEMENT MONTÉ, LES PIÈCES DOIVANT ÊTRE ENDOMMAGÉES (FIG. 1).**
 - 2. TOUTES LES OPÉRATIONS DE MONTAGE DOIVENT ÊTRE RÉALISÉES SUR UNE SURFACE PLANE (FIG 1).**
 - 3. UTILISER SUR TOUTES LES VIS À MÉTAUX D'ASSEMBLAGE**
- PREPARAÇÃO DA LAJE EM BETÃO.**

(SAC NO 1) LES RONDELLES D'ÉTANCHÉITÉ EN FIBRE (SAC NO 12).

- 4. IL EST RECOMMANDÉ QUE VOUS PORTIEZ LES GANTS PRÉVUS À CET EFFET LORS DU MONTAGE DE VOTRE ABRI.**
- 5. L'ABRI DOIT ÊTRE FIXE AU SOL SUR UNE SURFACE PLANE, PAR EXEMPLE, BETON, DALLES EN BETON, BOIS ETC. POUR UNE SURFACE DE BETON, VOIR CI-DESSUS.**

PRÉPARATION DE LA DALLE:

1. Le béton doit être coulé sur une épaisseur de 75mm, et dépasser de 100mm la hauteur du profilé de base soit 25mm au dessus du niveau du sol. L'utilisation d'une toile de polythène épaisse et résistante, placée sous la base aidera à empêcher l'humidité de monter du sol dans l'abri. Pour les dimensions de la dalle en béton, vous reporter à la fig. 2.

MONTAGEANLEITUNG.

VOR BEGINN:

1. Machen Sie sich mit den Montageanweisungen vertraut.
2. Überzeugen Sie sich an Hand der Teileliste (Seite 1,2) und der Schaubilder (seite 3,4), ob alles vollzählig ist und die Teile nicht beschädigt sind.

WICHTIG

- 1. STELLEN SIE DAS HAUS NICHT AN EINEM STÜRMISCHEN TAG AUF. JEDES HAUS WÜRDEN UNTER SOLCHEN WETTERBEDINGUNGEN BESCHÄDIGT WORDEN.**
- 2. DER GARTENSCHUPPEN MUß AUF EINER VOLLSTÄNDIG EBENEN FLÄCHE ERRICHTET WERDEN.**
- 3. SOFERN NICHT ANDERS ANGEZEIGT BENÜTZEN SIE DIE SCHRAUBEN UND WASSERDICHTEN FASERSCHEIBEN (BEUTEL 1 & 12) BEI ALLEN MONTAGEGÄNGEN.**
- 4. TRAGEN SIE DIE BELIEFERTEN HANDSCHUHE BEI DER MONTAGE.**
- 5. DAS HAUS MUß AUF EINER FESTEN EBENEN FLÄCHE VERANKERT WERDEN, Z.B. AUF BETON, BETONPLATTEN, HOLZ. BEI BETONFLÄHEN SEHEN SIE UNTEN.**

VORBEREITUNG DES BETONFUNDAMENTS:

Die Betonplattform soll mindestens 70-80mm stark und mindestens 100mm länger und breiter als der metall-grundrahmen sein. die plattform sollte außerdem mindestens 25mm über dem boden sein. Ein laken aus hochleistungskunststoff unter dem fundament wird dazu helfen, feuchtigkeit vorzubeugen, die von der erde in den schuppen

1. A camada de betão deverá ter uma espessura mínima de 75mm e ocupar uma área pelo menos 100mm

hineindringt.

BOUWHANDLEIDING.

Voordat U met de bouw begint, maakt U zich dan eerst goed vertrouwd met de bouwaanwijzingen. Kruis alle ontvangen onderdelen op de onderdelenlijst (pagina 1,2) en diagram (pagina 3&4) aan. Controleer of de onderdelen niet zijn beschadigd.

BELANGRIJK !

- 1 MONTEER UW SCHUUR NIET OP EEN WINDERIGE DAG. DE KANS DAT ER TÏDENS HET MONTEREN BESCHADIGINGEN ONTSTAAN IS DAN ZEER GROOT AANWEZIG (Afb 1).**
- 2 DE BOUW DIENT UITGEVOERD TE WORDEN OP EEN GEHEEL VLAkke ONDERGROND (Afb 1)**
- 3 TENZY ANDERS AANGEGEVEN MOETEN BIJ HET MONTEREN DE SCHROEVEN EN VEZELRINGEN UIT (Zak 1 en 12) WORDEN GEBR UIKT.**
- 4 HET IS AAN TE RADEN DE MEEGELEVERDE HANDSCHOENEN BIJ HET MONTEREN TE DRAGEN**

VOORBEREIDING VAN DE BOUWPLAATS VAN BETON

1 Het beton dient minimaal 75mm dik te worden gelegd. Ongeveer 25mm boven grondniveau dient het beton minstens 100mm breder te zijn dan de totale maal van het metalen funderingsraam. Afb. 2.

INSTRUÇÕES DE MONTAGEM.

Antes de começar, leia atentamente as instruções de montagem. Verifique cuidadosamente todas as peças que recebeu confrontando-as com a lista (página 1,2) e com o diagrama (páginas 3,4). Certifique-se que nenhuma peça está danificada

NÃO ESQUEÇA !

- 1. AVISO DE TEMPESTADE! NÃO PROCEDA À MONTAGEM DO SEU ABRIGO NUM DIA VENTOSO. QUALQUER ABRIGO DEIXADO PARCIALMENTE MONTADO PODE FICAR SERIAMENTE DANIFICADO (FIG. 1).**
- 2. TODAS AS OPERAÇÕES DE MONTAGEM DEVEM SER EFECTUADAS NUMA SUPERFÍCIE COMPLETAMENTE NIVELADA (FIG. 1).**
- 3. SALVO INDICAÇÃO EM CONTRÁRIO, OS PARAFUSOS E ANILHAS EM FIBRA (SACOS 1E12) DEVEM SER UTILIZADOS EM TODAS AS OPERAÇÕES DE MONTAGEM.**
- 4. RECOMENDAMOS QUE UTILIZE AS LUVAS FORNECIDAS QUANDO PROCEDER À MONTAGEM DESTE PRODUTO.**

mais larga que a dimensão global da estrutura metálica da base e ficar aproximadamente 25mm

acima do nível do chão. Uma tela de polietileno resistente ao desgaste colocada sob a área da base irá ajudar a prevenir a subida de humidade proveniente do chão do abrigo. Para as medidas da base em betão veja a Fig. 2.

INSTRUCCIONES DE MONTAJE.

Antes de comenzar lea detenidamente las instrucciones de montaje. Compruebe que estén todas las piezas enumeradas en la lista de elementos (página 1,2) y en los diagramas (páginas 3 y 4).

Asegúrese además de que ningún elemento esté dañado.

1. PRESTE ATENCIÓN A LA

METEOROLOGÍA. NO INTENTE LEVANTAR EL EDIFICIO EN UN DÍA DE VIENTO. CUALQUIER COMPONENTE QUE QUEDE A MEDIO MONTAR PUEDE SUFRIR DAÑOS IMPORTANTES. (FIG. 1).

2. TODAS LAS OPERACIONES DE MONTAJE DEBEN DE REALIZARSE SOBRE UNA SUPERFICIE TOTALMENTE PLANA Y AL MISMO NIVEL. (FIG. 1)

3. A MENOS QUE SE INDIQUE LO CONTRARIO SE DEBE DE HACER USO DE TORNILLOS Y ARANDELAS DE FIBRA (BOLSAS 1 Y 12) EN TODAS LAS OPERACIONES DE MONTAJE.

4. SE LE RECOMIENDA EL USO DE LOS GUANTES QUE SE ADJUNTAN SIEMPRE QUE SE DISPONGA A MONTAR CUALQUIER

ELEMENTO DEL PRODUCTO.

PREPARACIÓN DEL LUGAR EL HORMIGÓN.

1. En primer lugar, debe extender una capa de hormigón de al menos 75mm de ancho y al menos 100mm mayor que el total del armazón de la base de metal y con 25mm sobre el nivel del suelo. Una pieza de policeno especial resistente que pueda situar bajo la base ayudará a evitar que la humedad del suelo llegue a la nave. Para las medidas de la base de hormigón vea la fig 2.

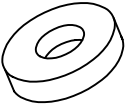
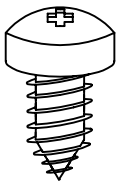

WASHERS TO BE USED ON ALL SCREWS
 VEZELRINGEN VOOR GEBRUIK ONDER ALLE SCHROEVEN
 RONDELLES POUR TOUTES LES VIS
 FASER SCHEIBEN FÜR VERWENDUNG MIT ALLEN SCHRAUBEN
 ARANDELAS QUE DEBEN USARSE CON TODOS LOS TORNILLOS
 ANILHAS PARA SEREM UTILIZADAS EM TODOS OS PARAFUSOS

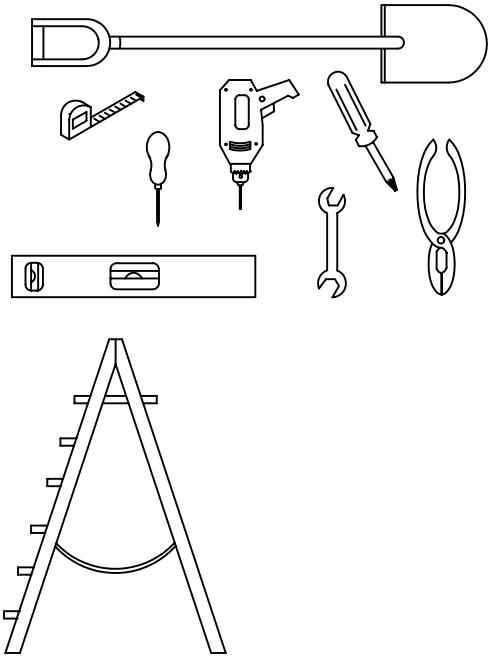

FIG. 1

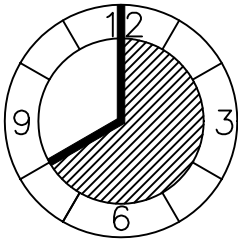
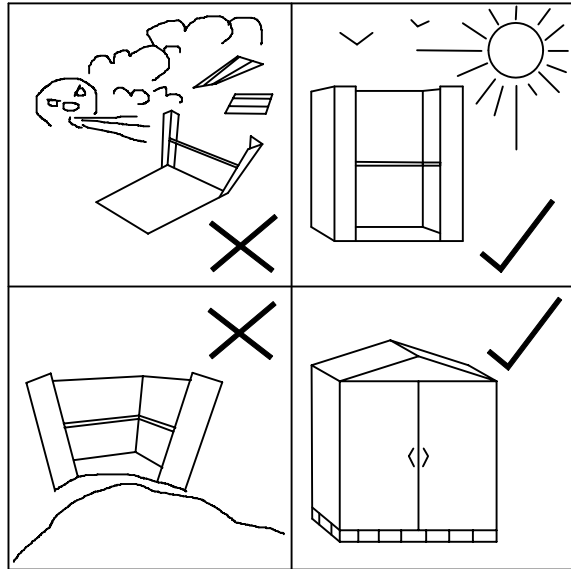
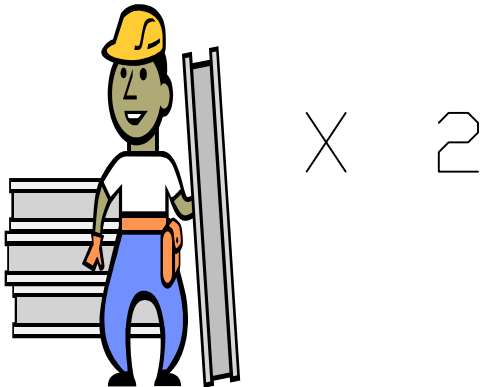
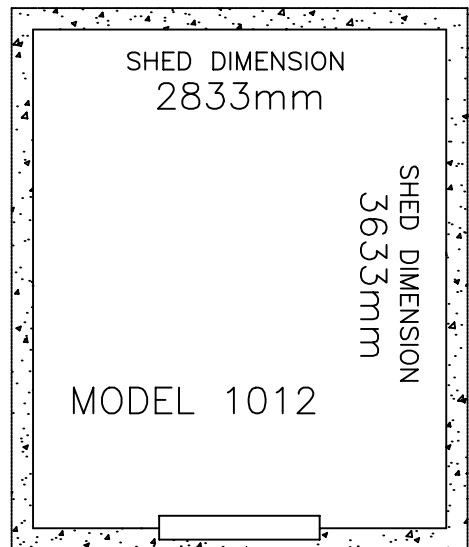

FIG. 2



BASE DIMENSION
3020mm



FRONT DEVANT
 VOORKANT VORDERSEITE
 FRENTE

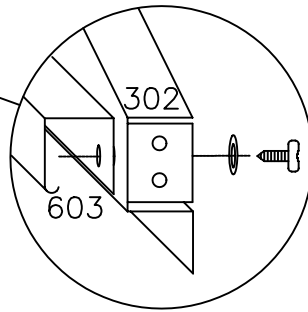
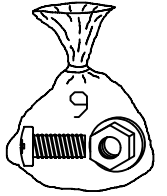
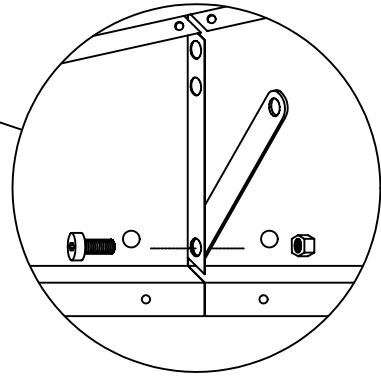
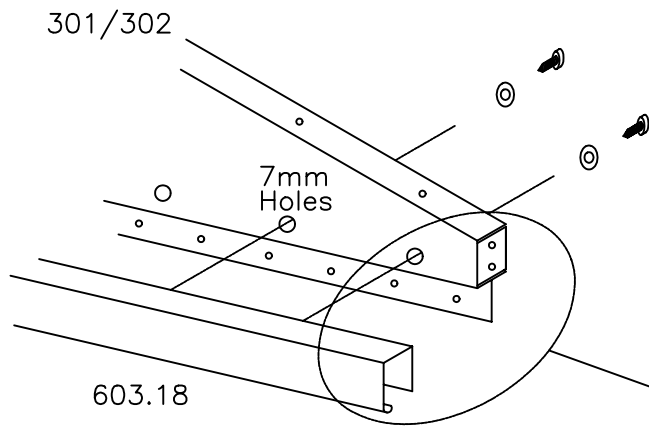
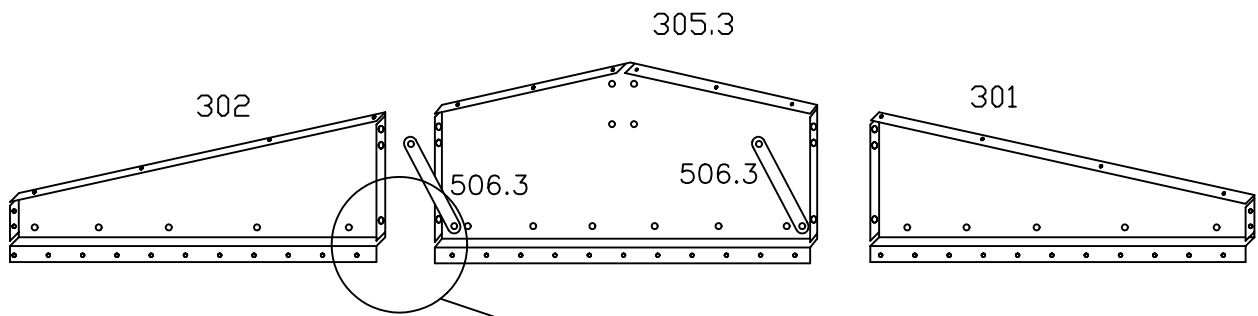

OK

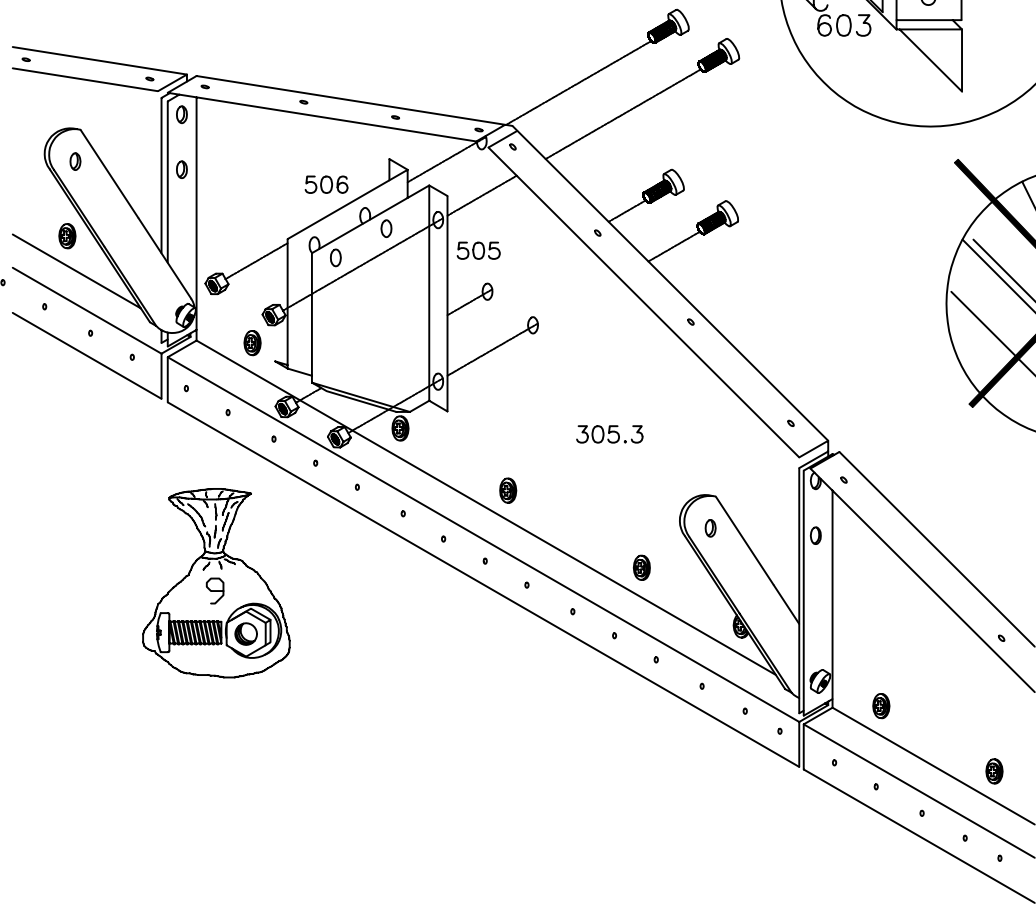
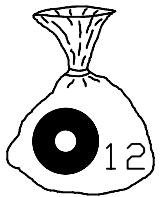
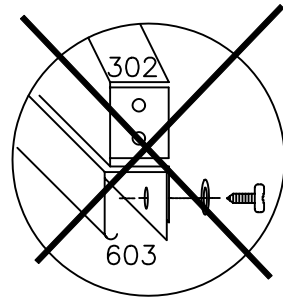
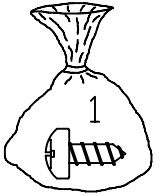

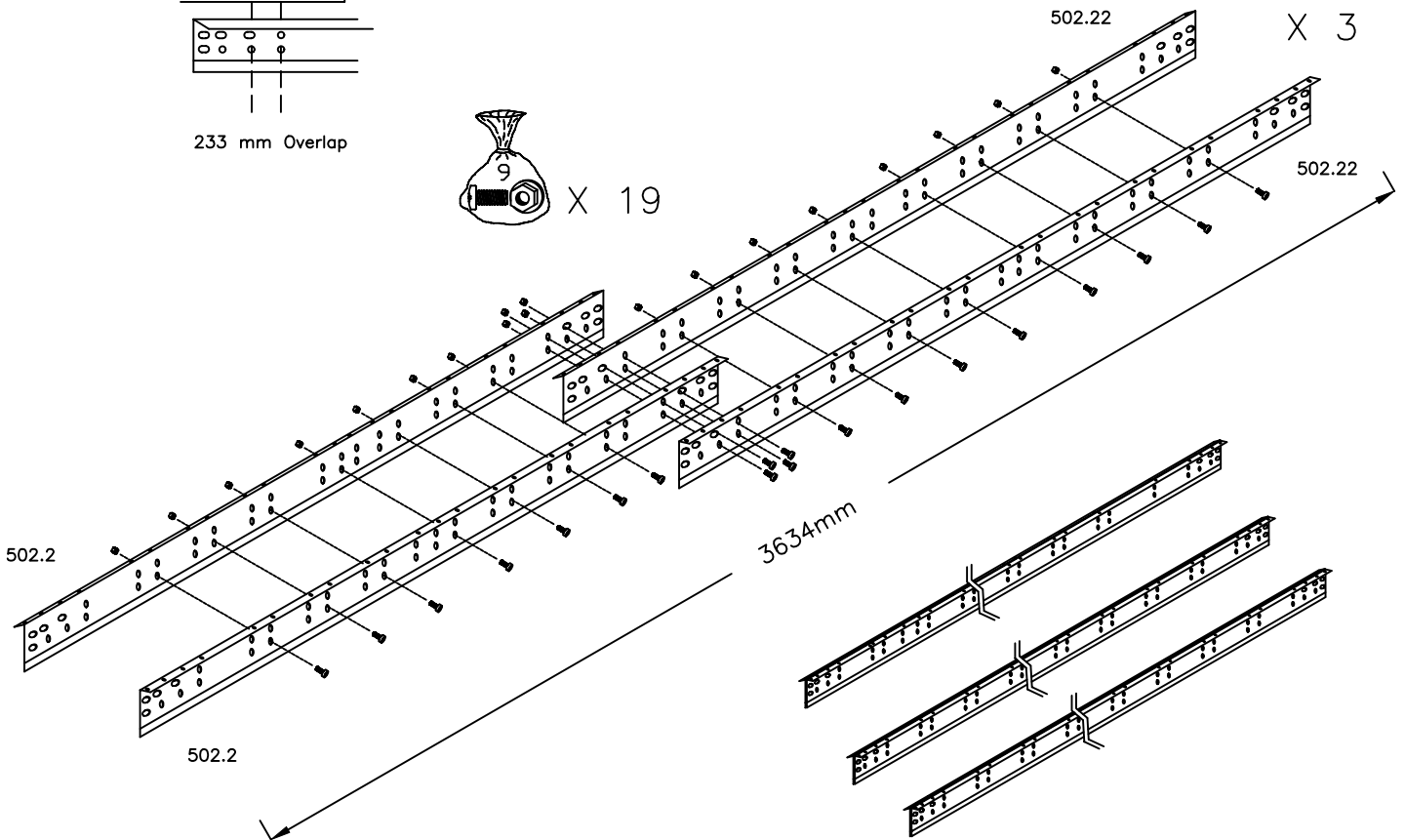
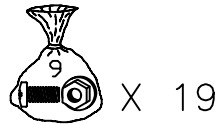
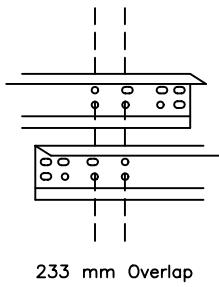
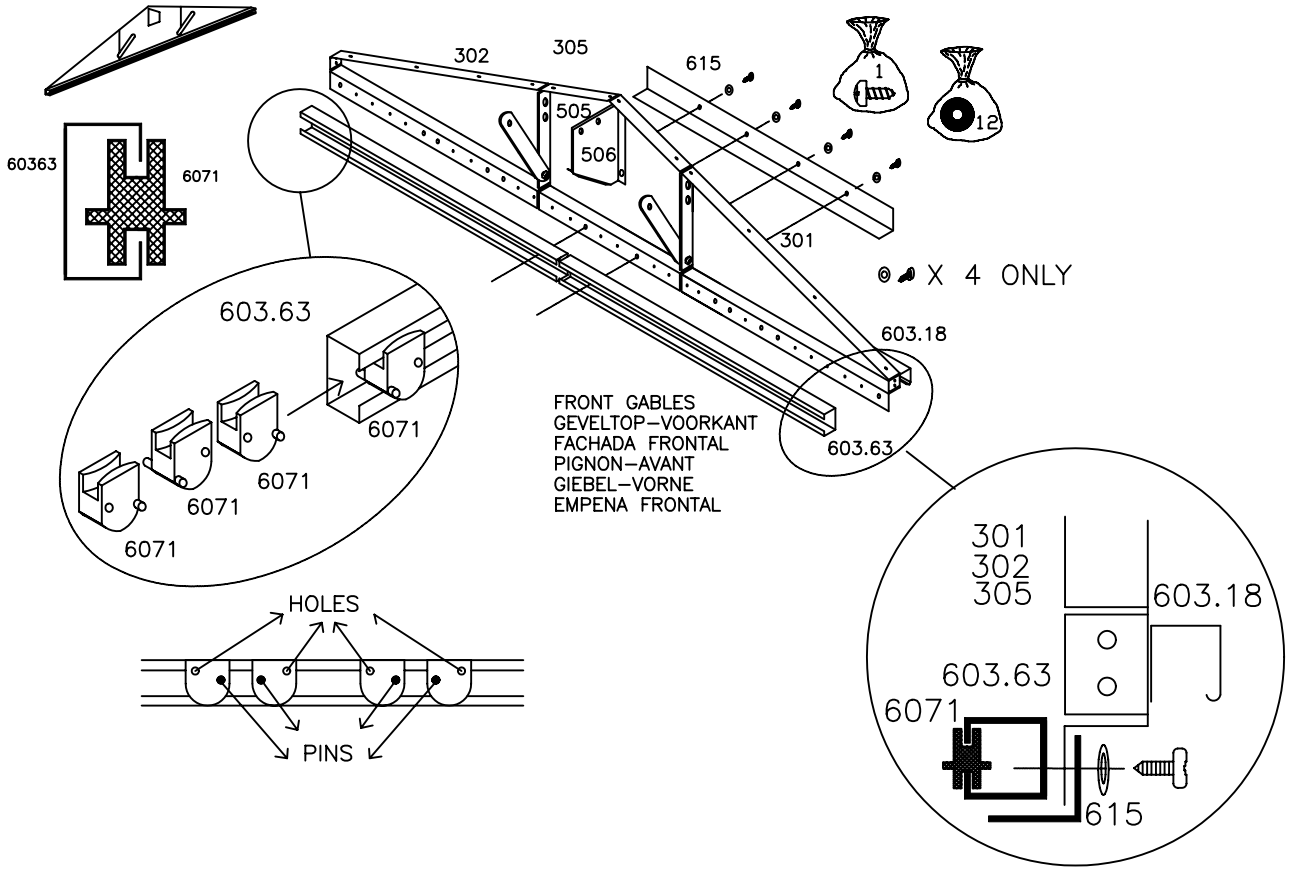

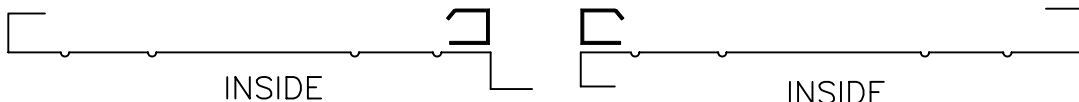
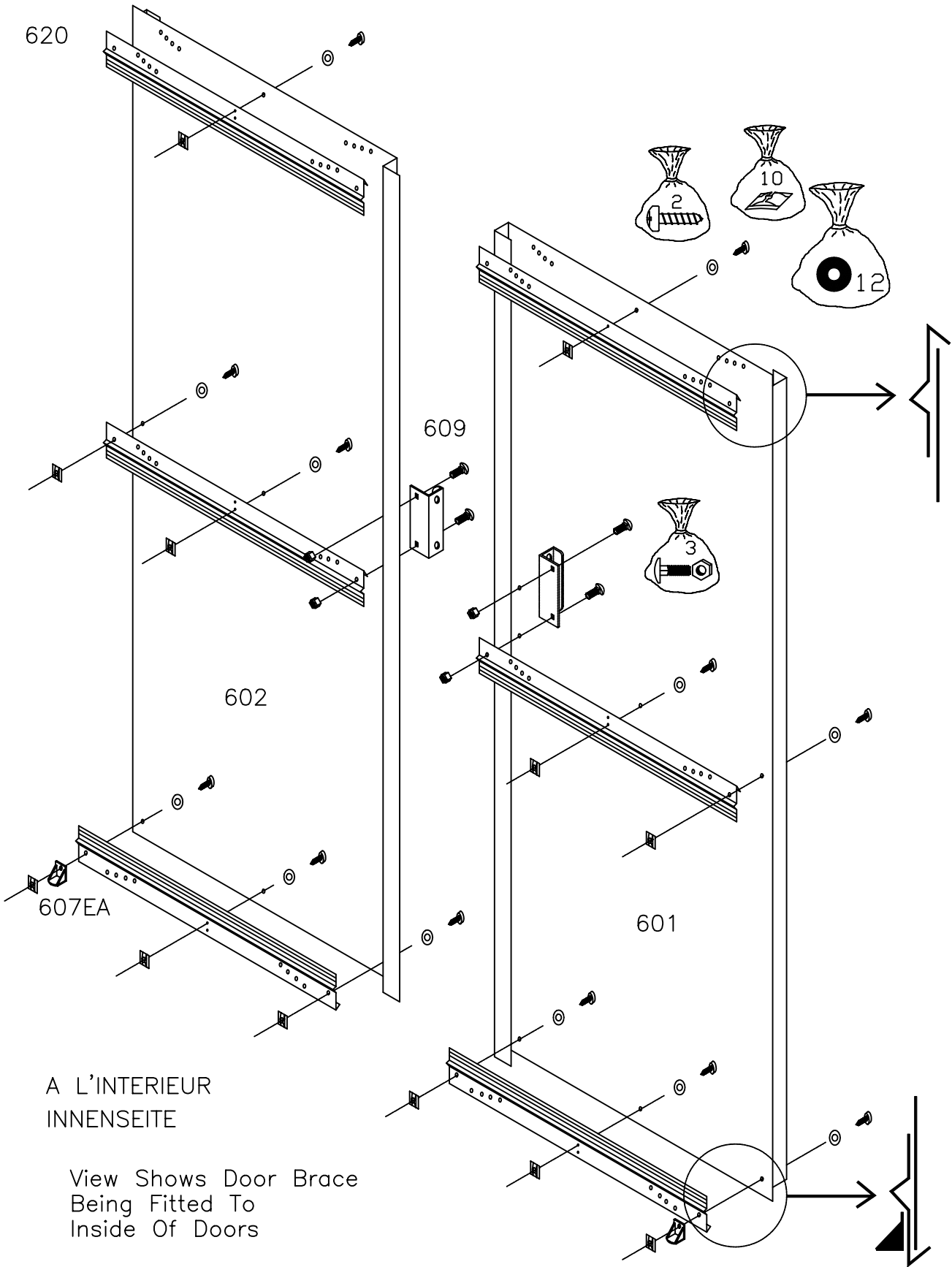

10

A L'INTERIEUR
INNENSEITE

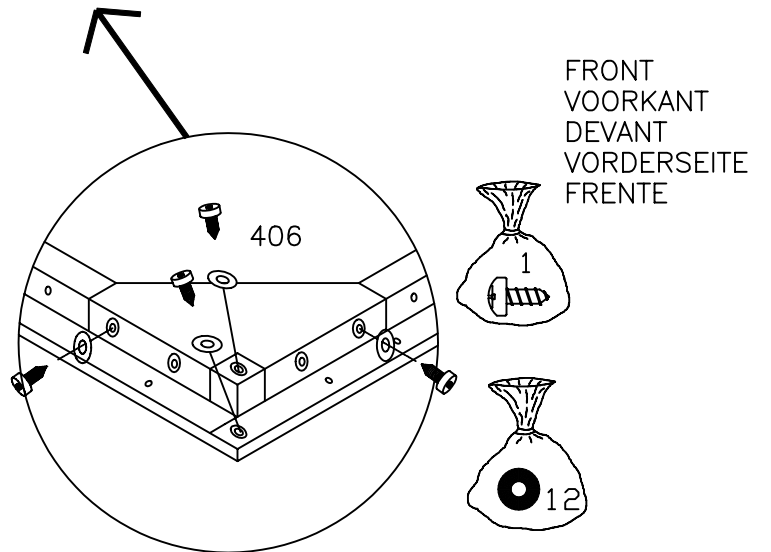
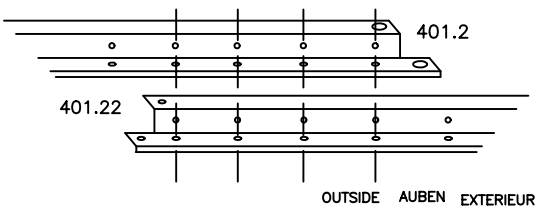
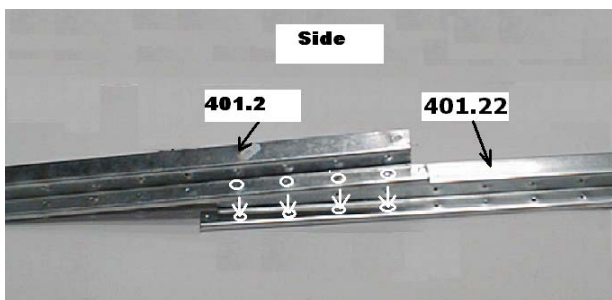
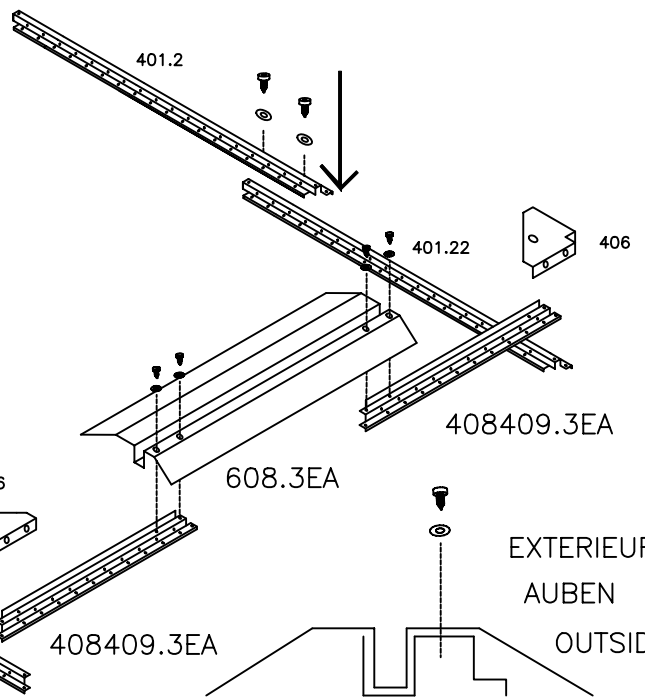
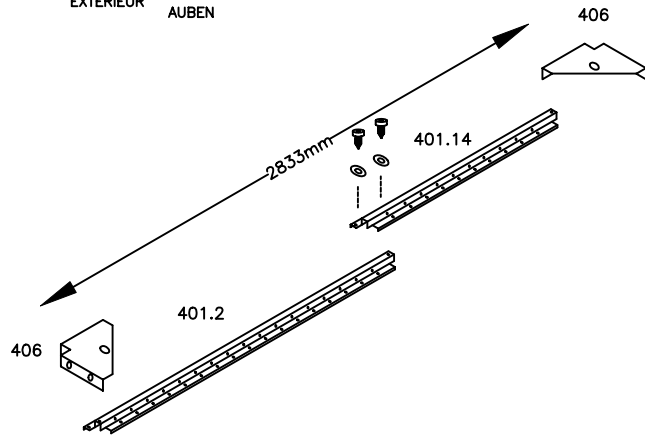
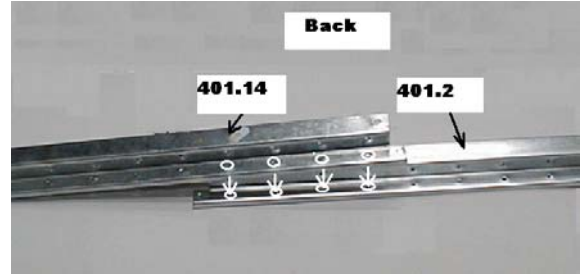
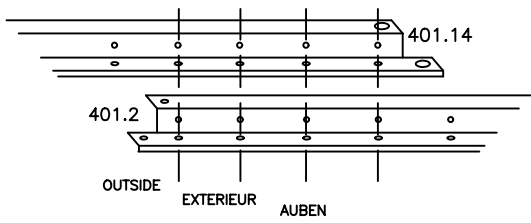

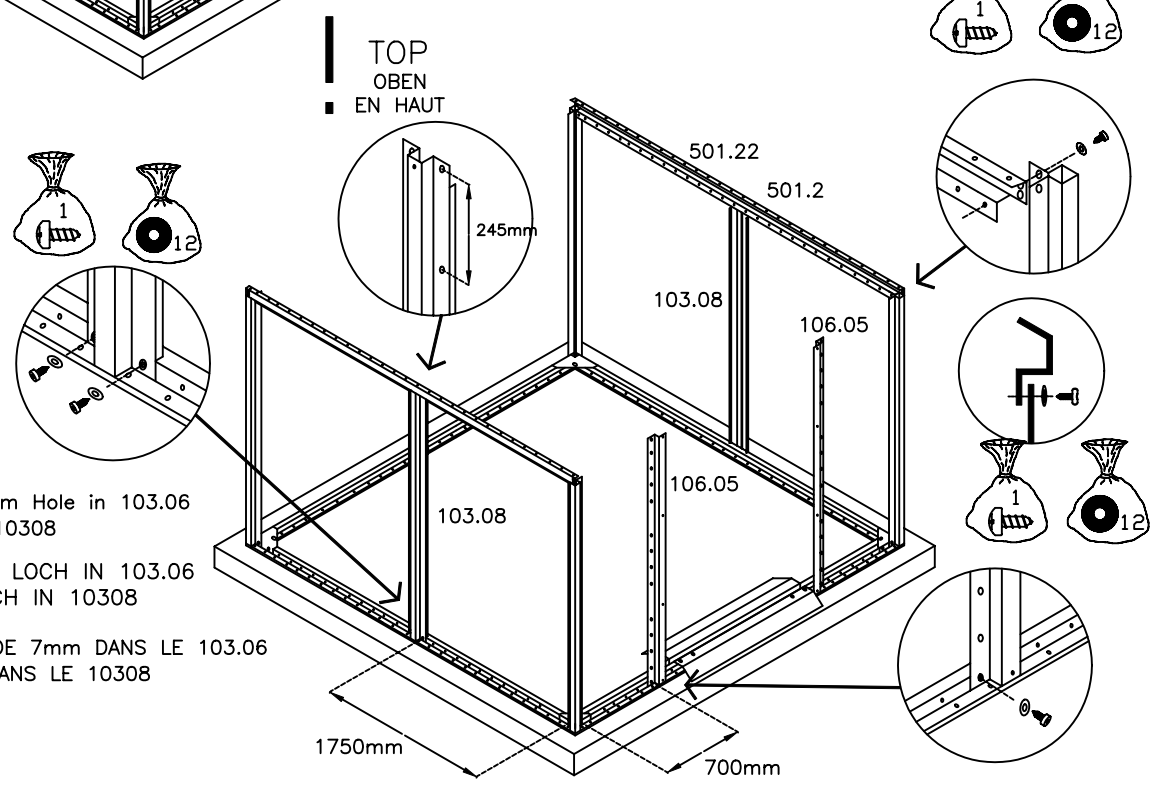
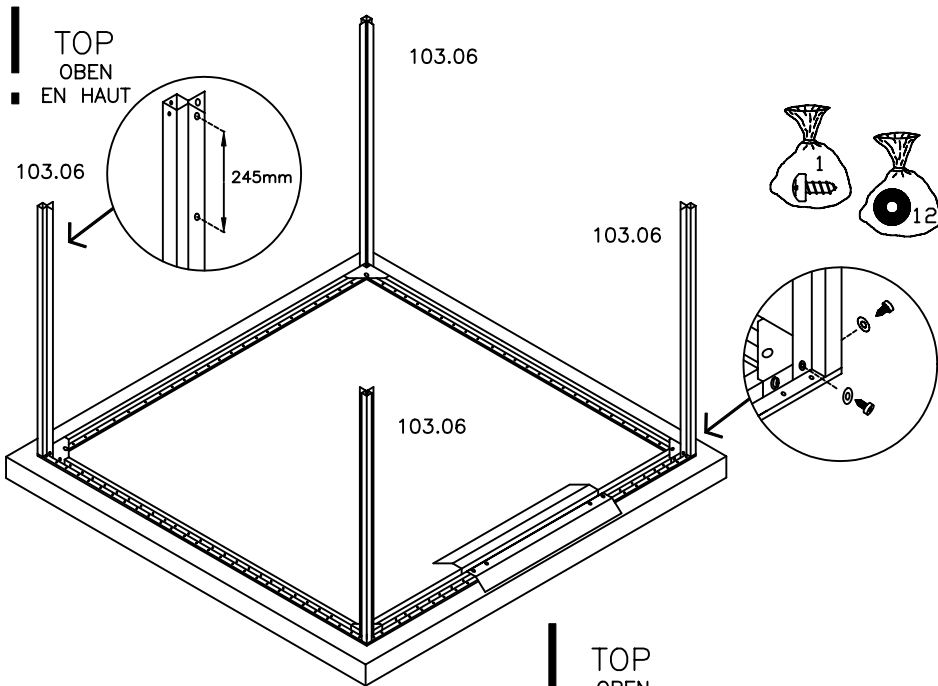

1750mm From 7mm Hole in 103.06
to 7mm hole in 10308

1750mm VOM 7mm LOCH IN 103.06
BIS ZUM 7mm LOCH IN 10308

1750mm AU TROU DE 7mm DANS LE 103.06
AU TROU DE 7mm DANS LE 10308

1750mm

700mm

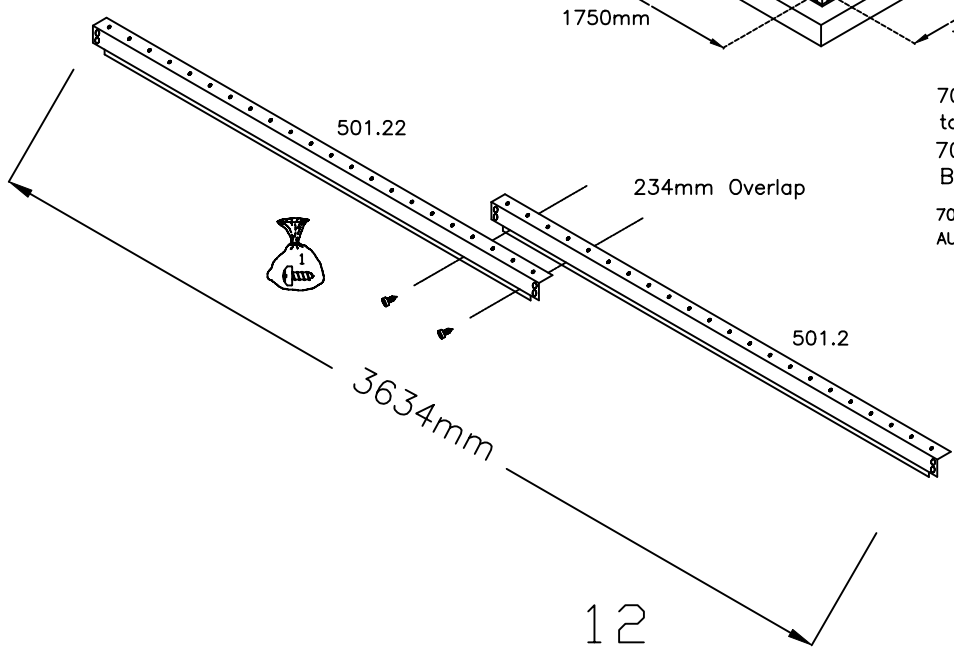

700mm From 7mm Hole in 103.06
to 7mm hole in 10605

700mm VOM 7mm LOCH IN 103.06
BIS ZUM 7mm LOCH IN 10605

700mm DU TROU DE 7mm DANS LE 103.06
AU TROU DE 7mm DANS LE 10605

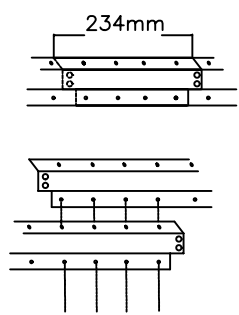

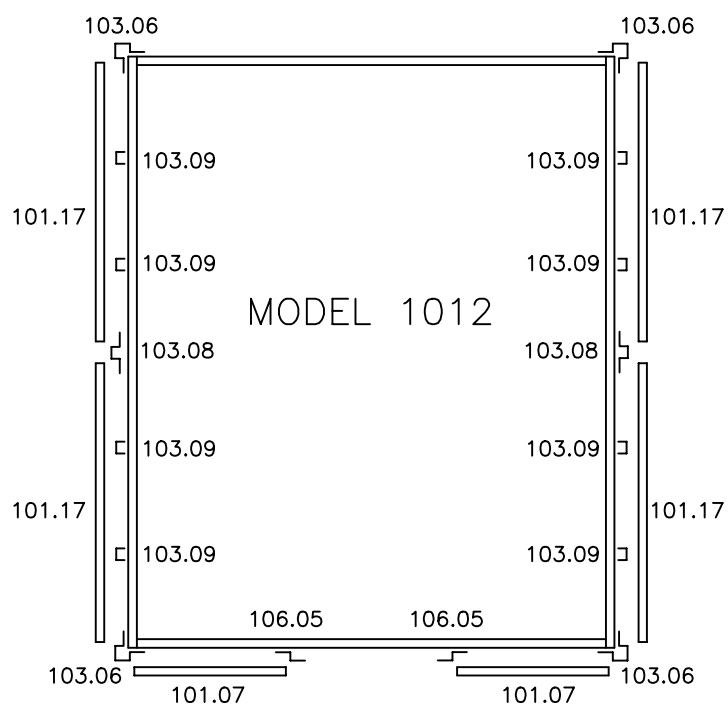
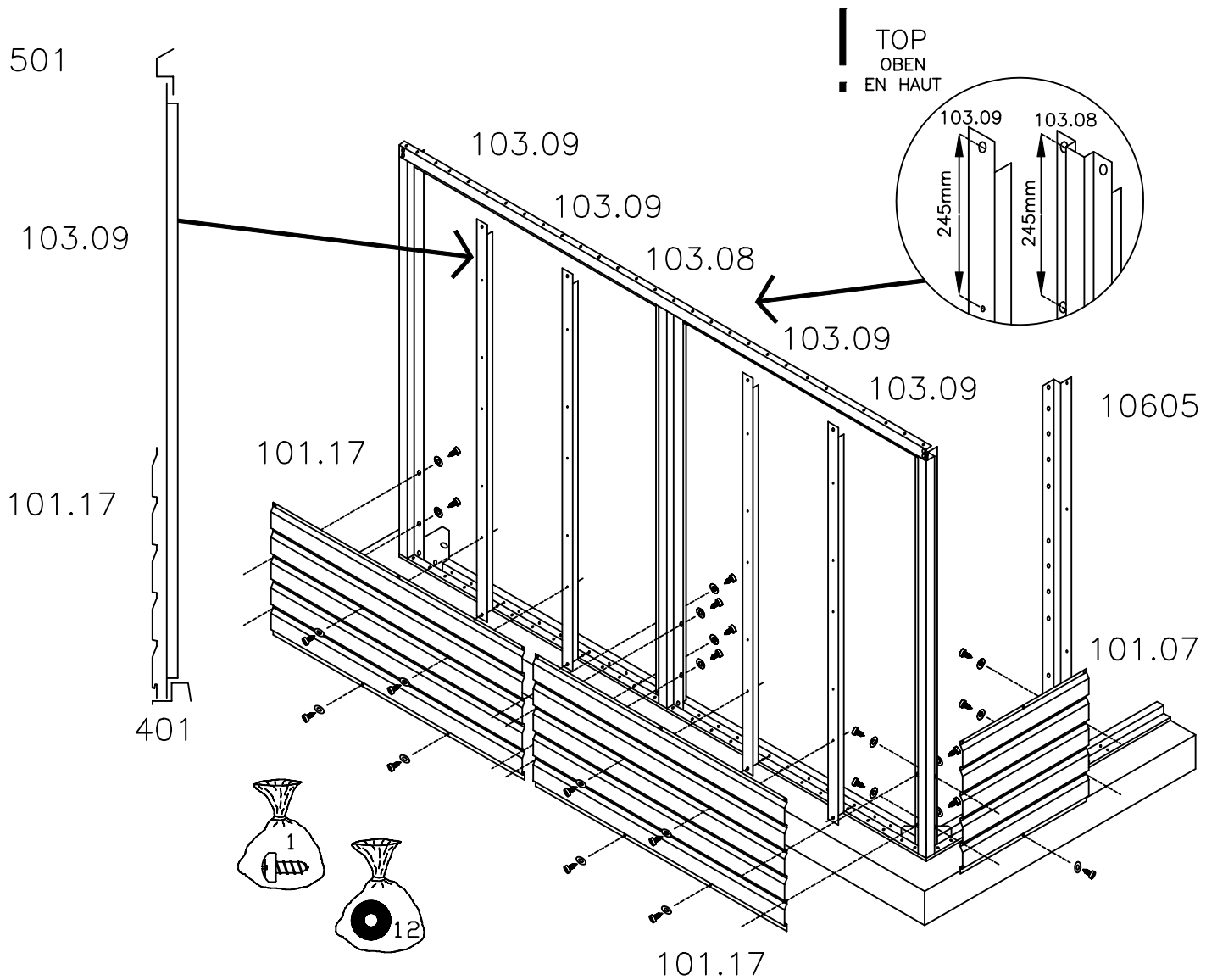

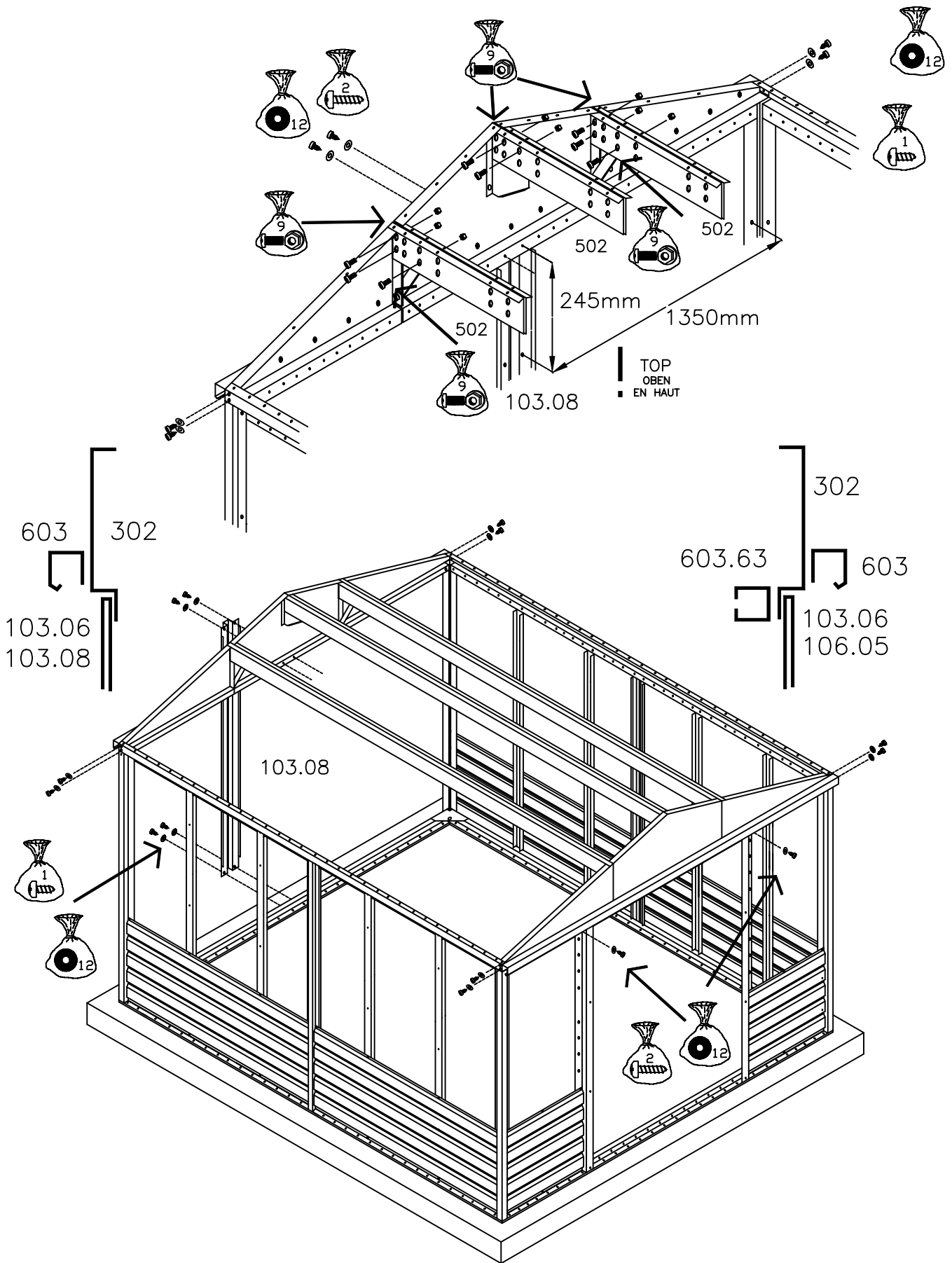

TOP
OBEN
EN HAUT

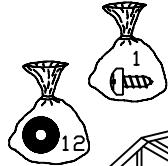
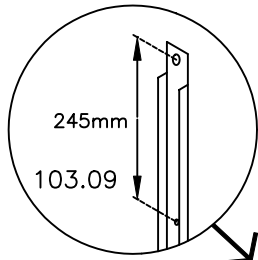

103.09

101.13

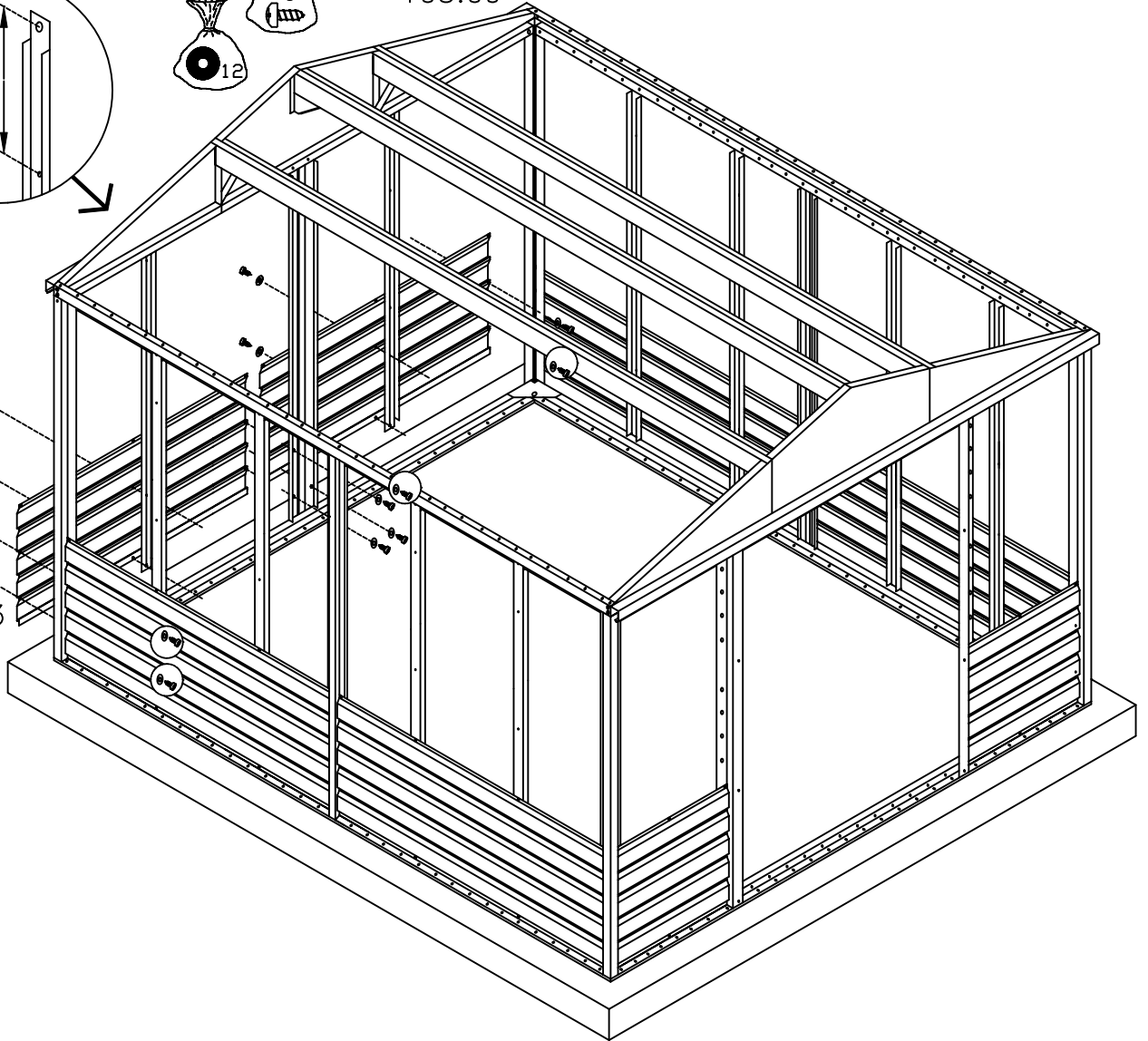

MODEL 1012

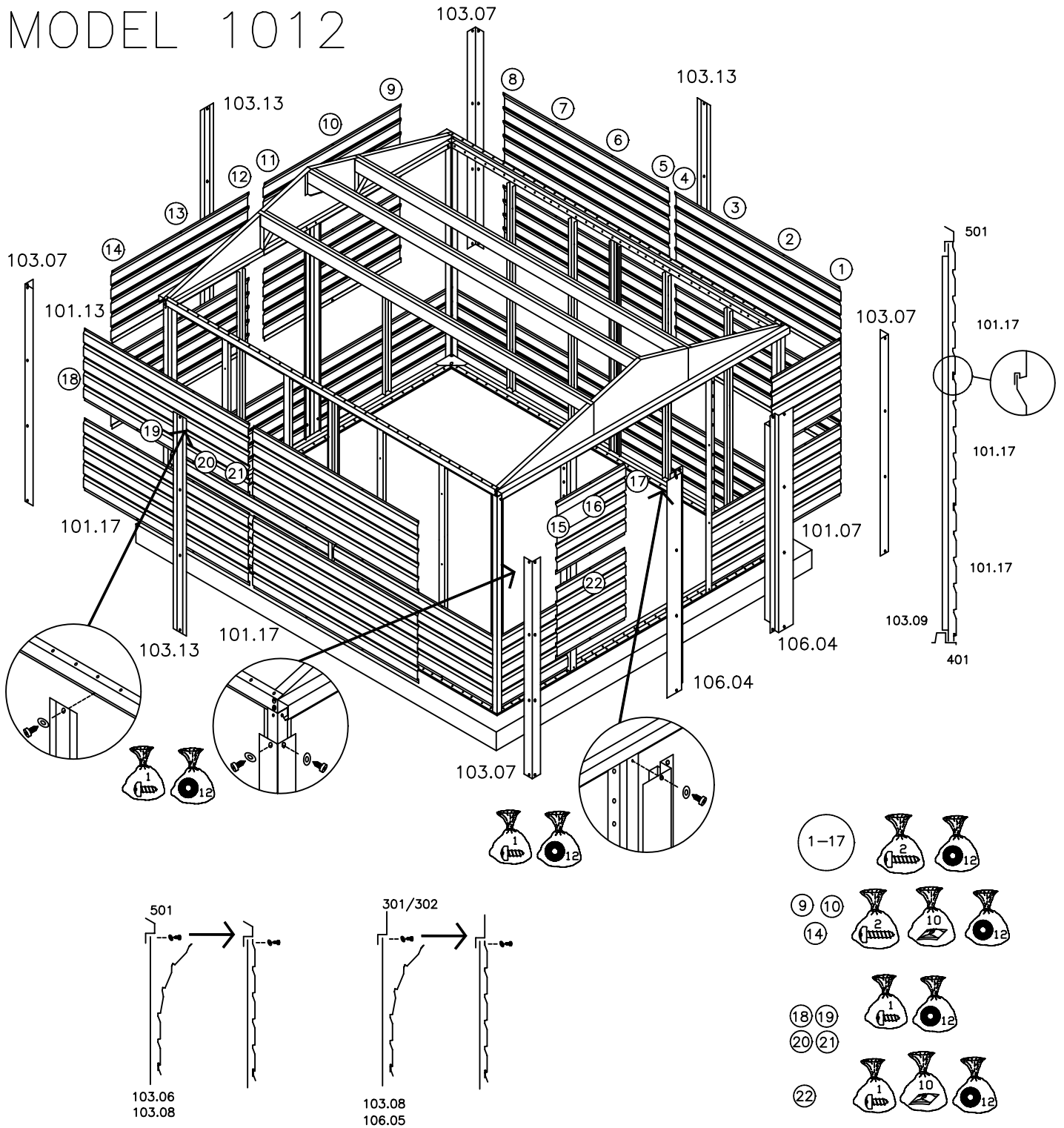

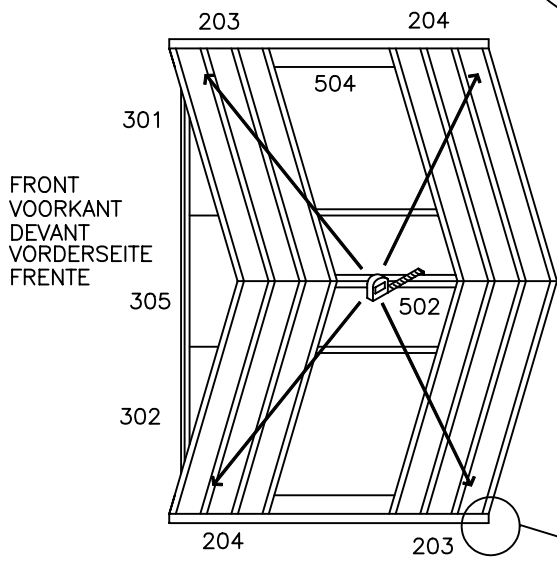
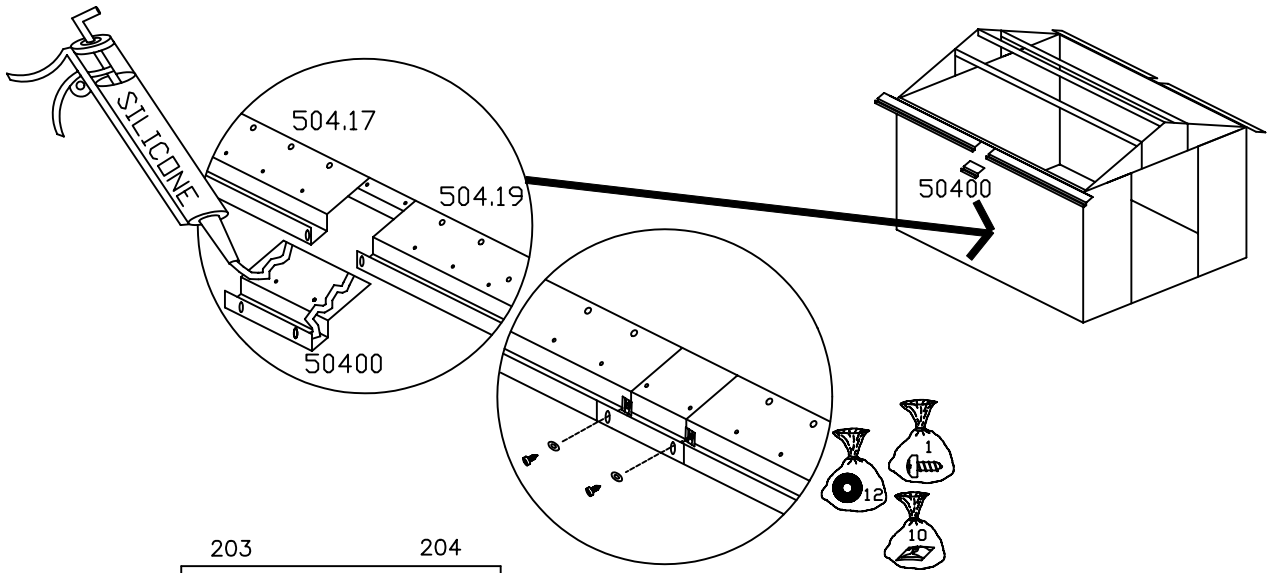
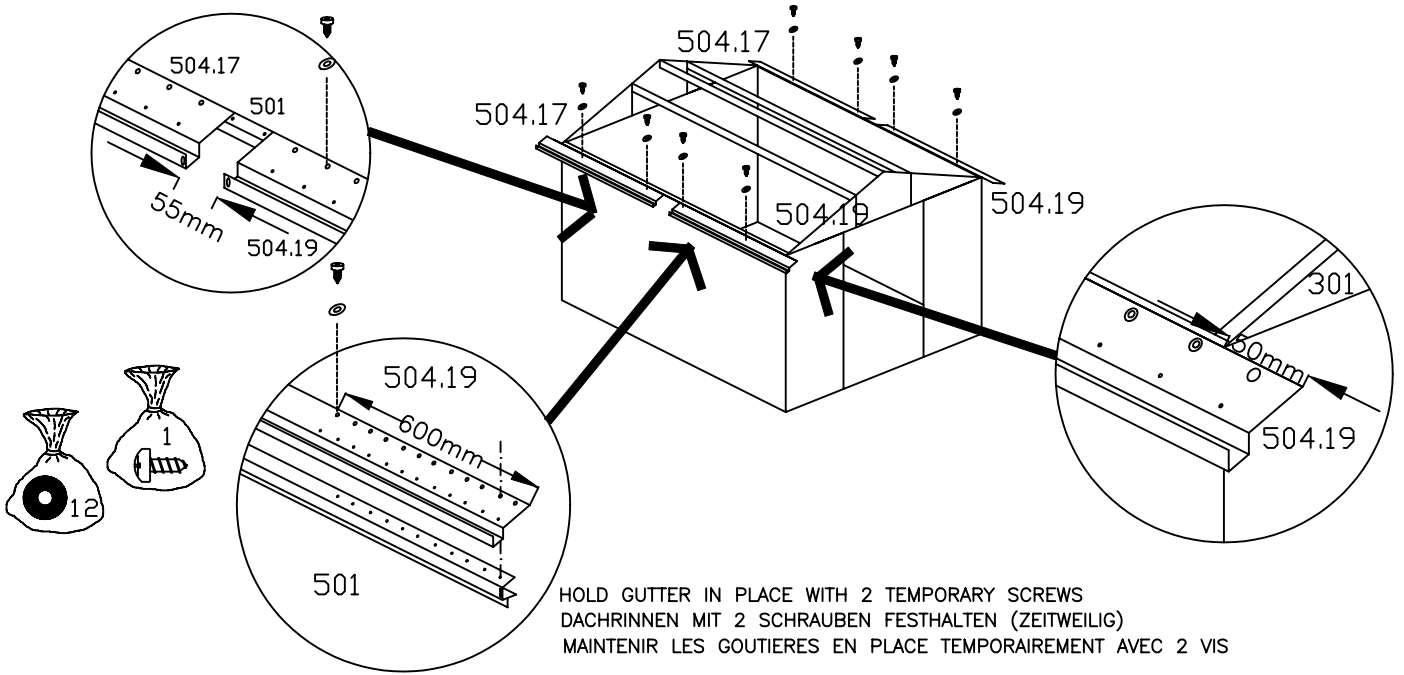

ENSURE ROOF FRAME IS "SQUARE" BEFORE SECURING PANELS
 EQUARREZ LE METIER AVANT DE FIXER LES PANNEAUX
 DACHRAHMEN RECHTWINKLIG VOR DACHPLATTEN FESTZUMACHEN

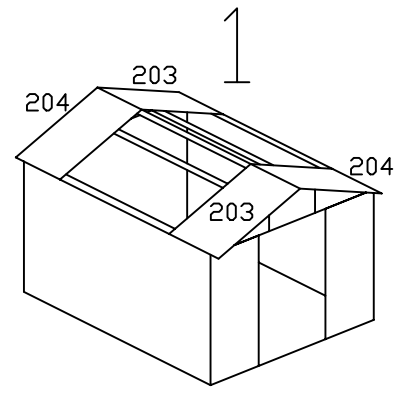
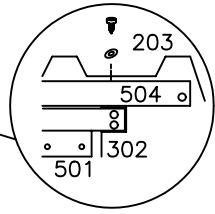

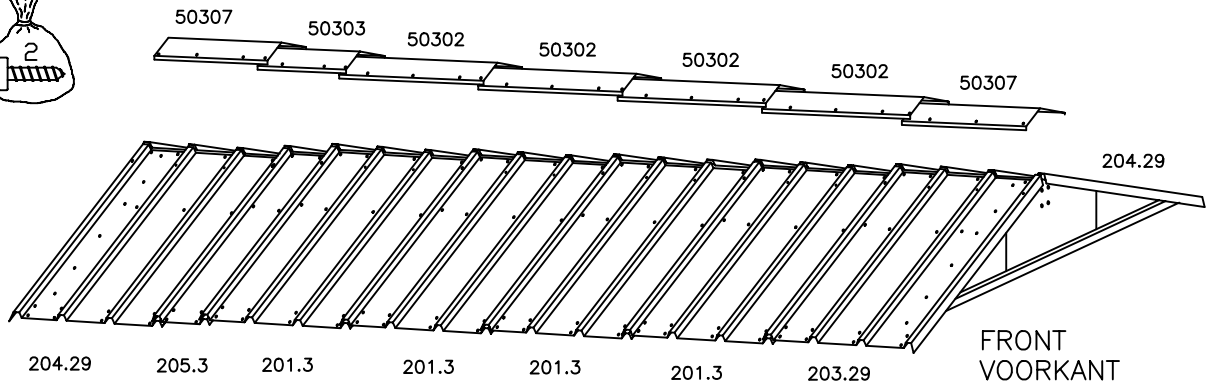
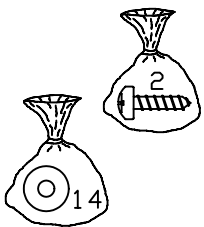
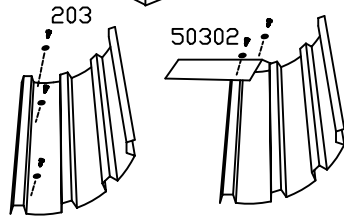
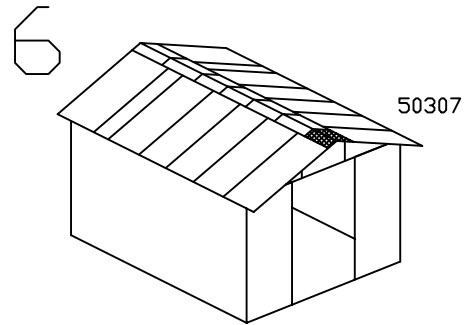
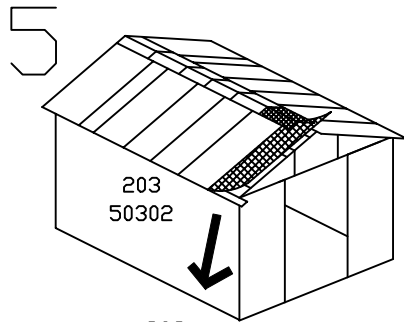
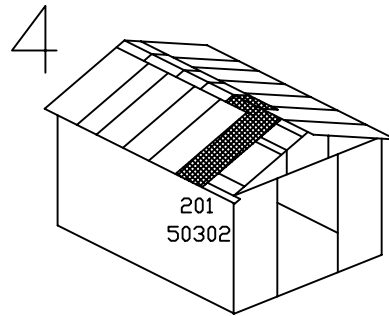
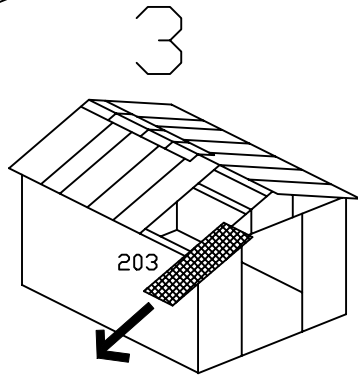
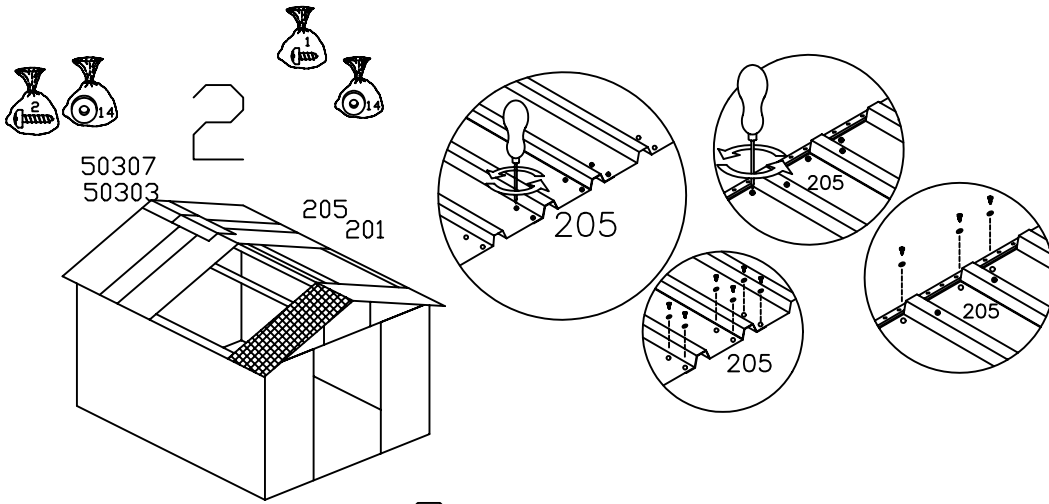

FRONT
VOORKANT
DEVANT
VORDERSEITE
FRENTE

FRONT
 VOORKANT
 DEVANT
 VORDERSEITE
 FRENTE

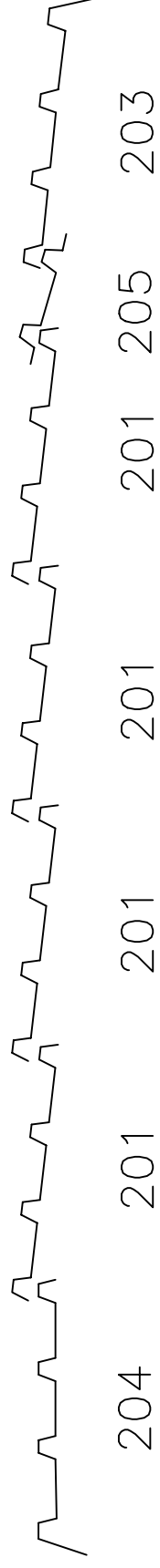
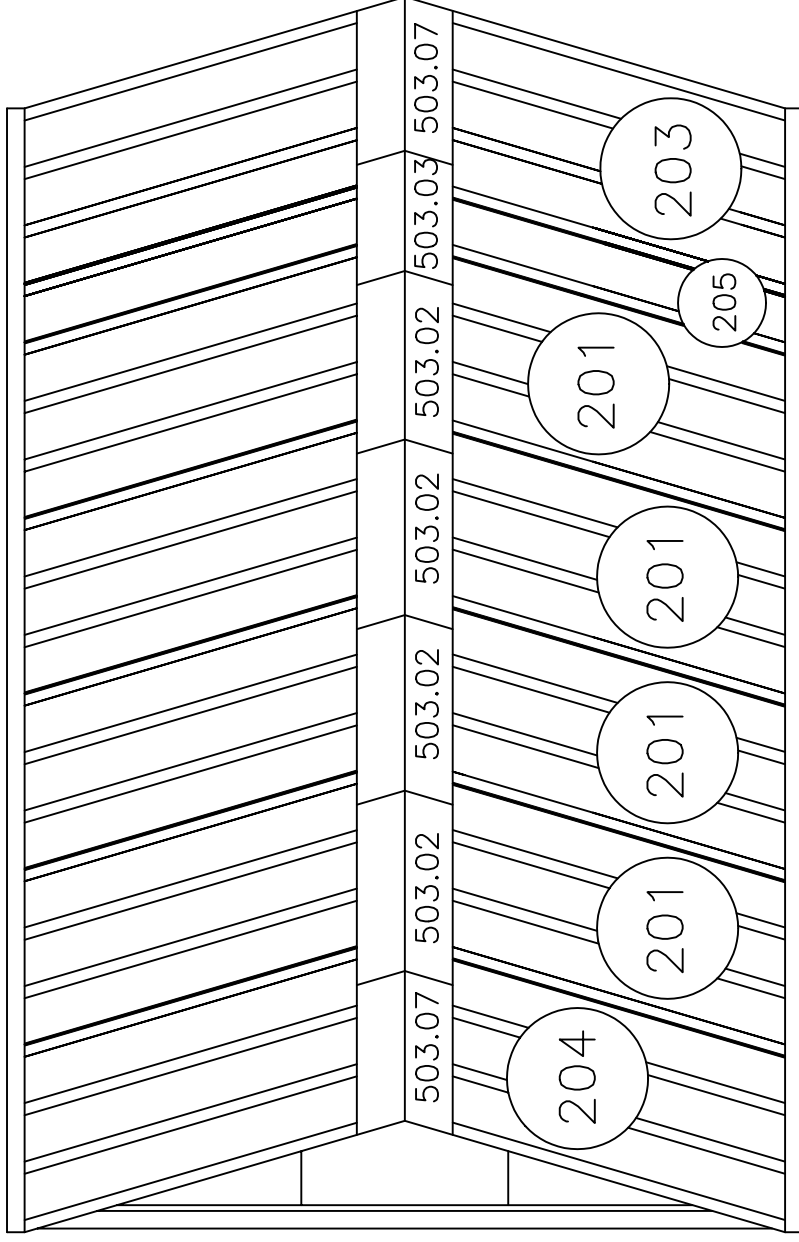

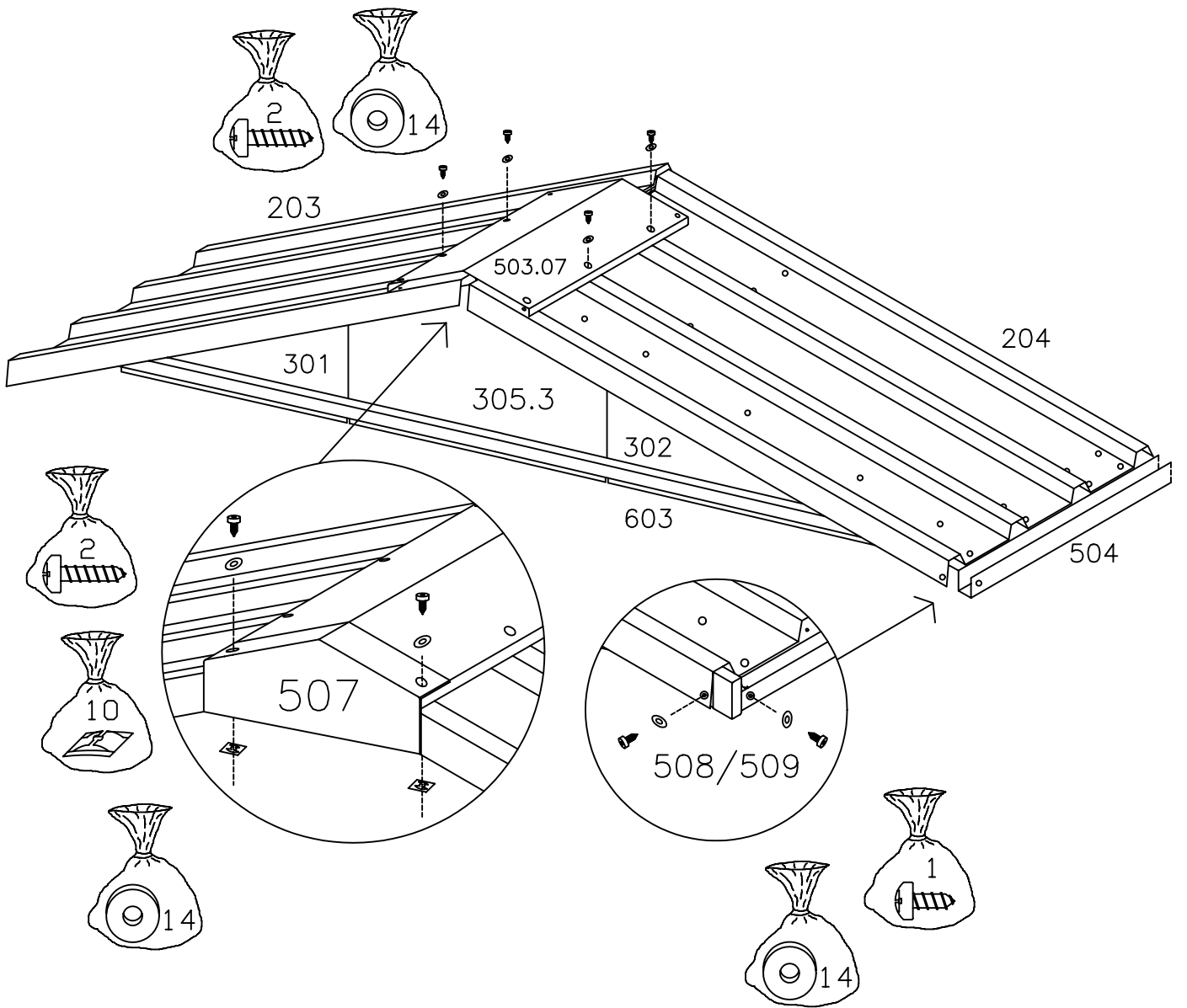

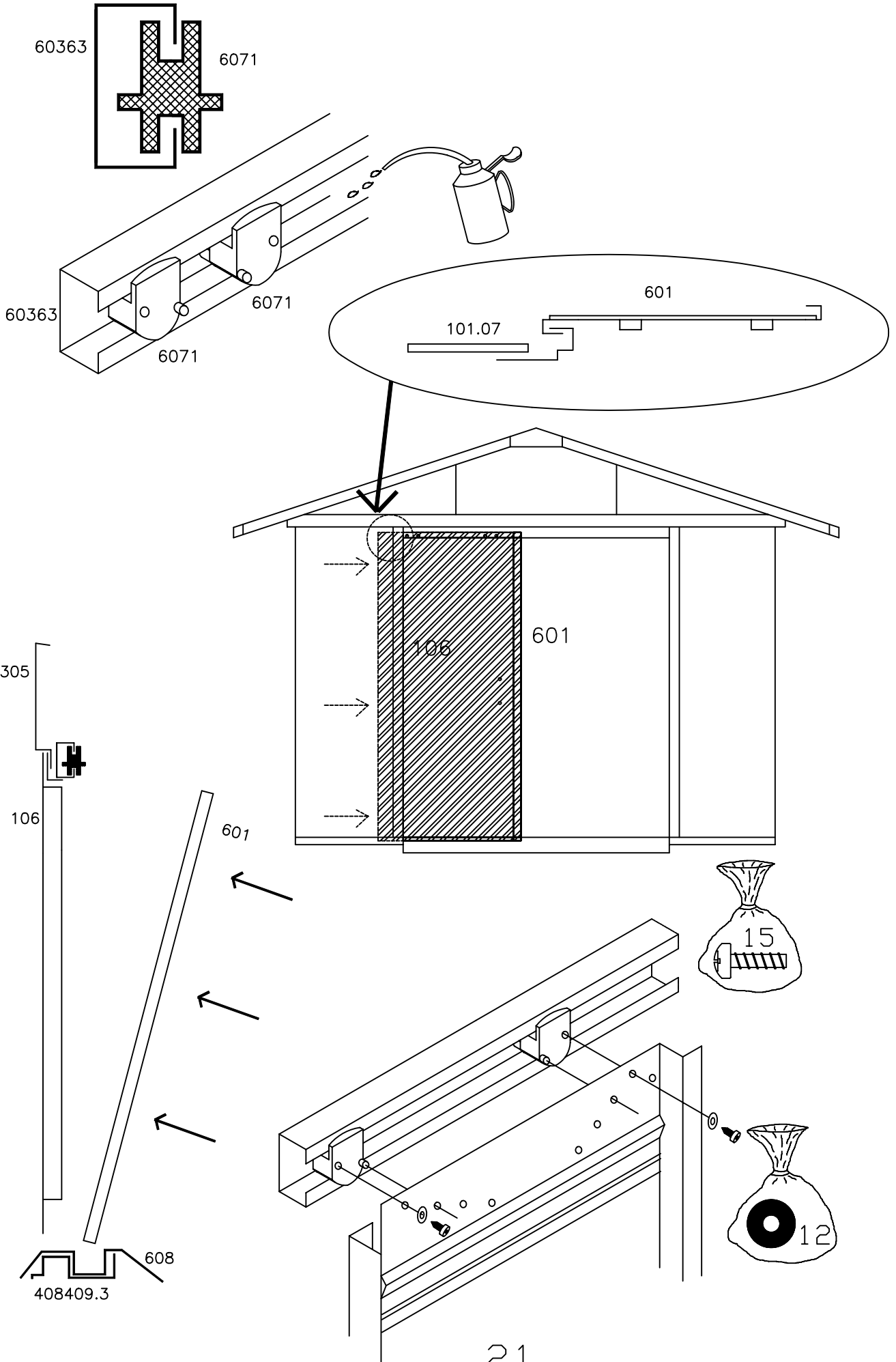

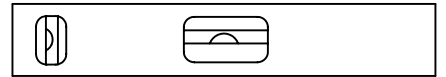
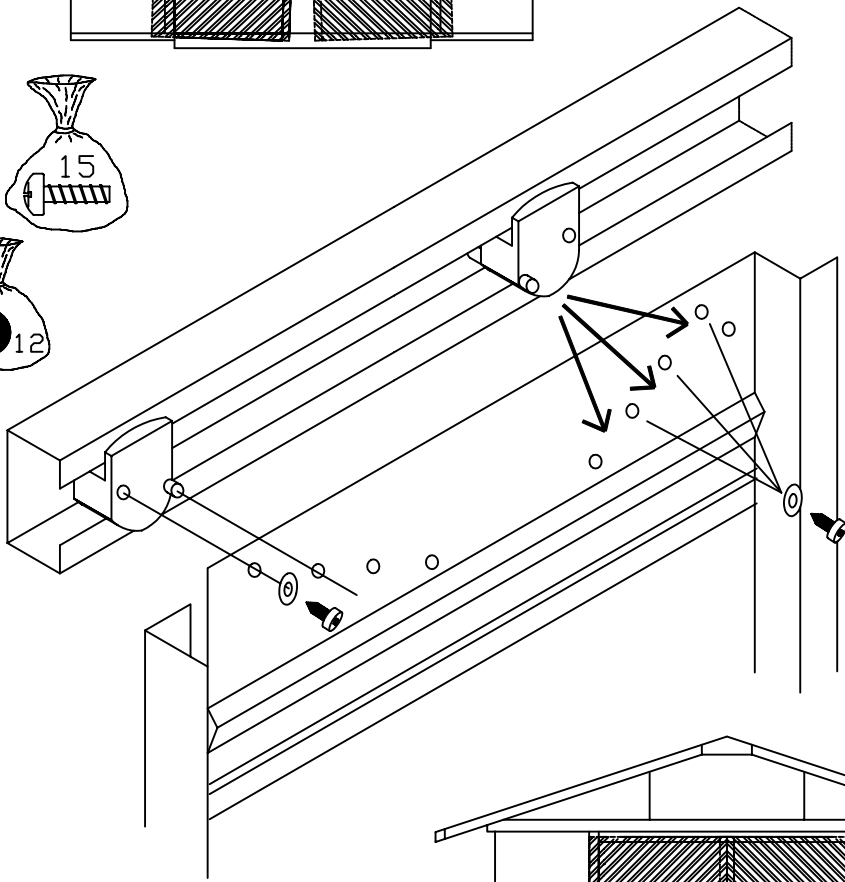
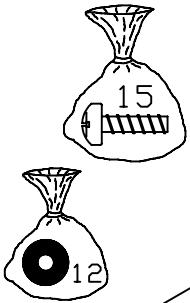
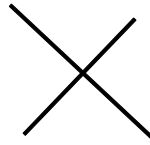
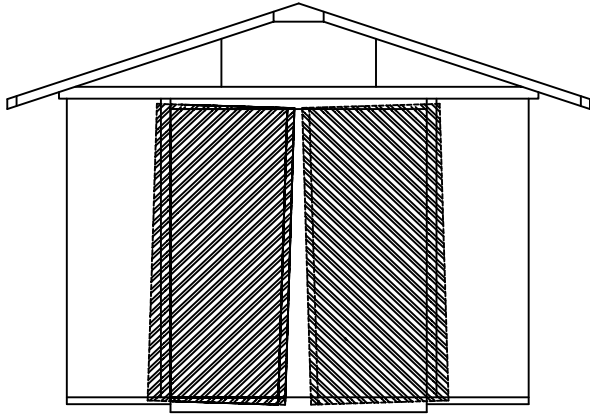

DOOR ADJUSTMENT
TURHOHE
REGLAGE DES PORTES

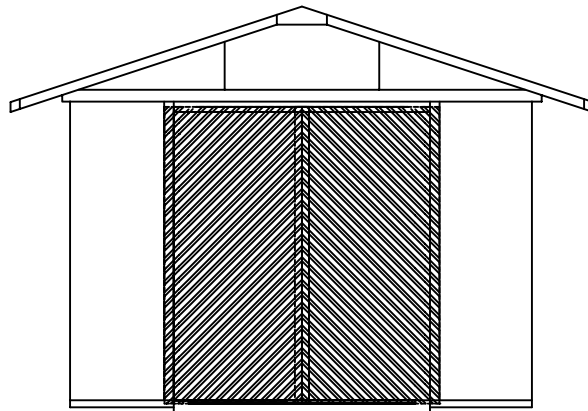
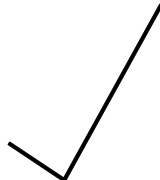

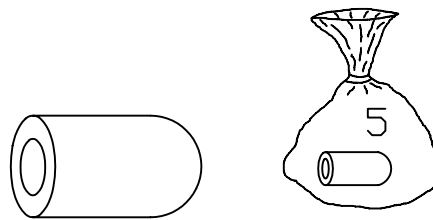
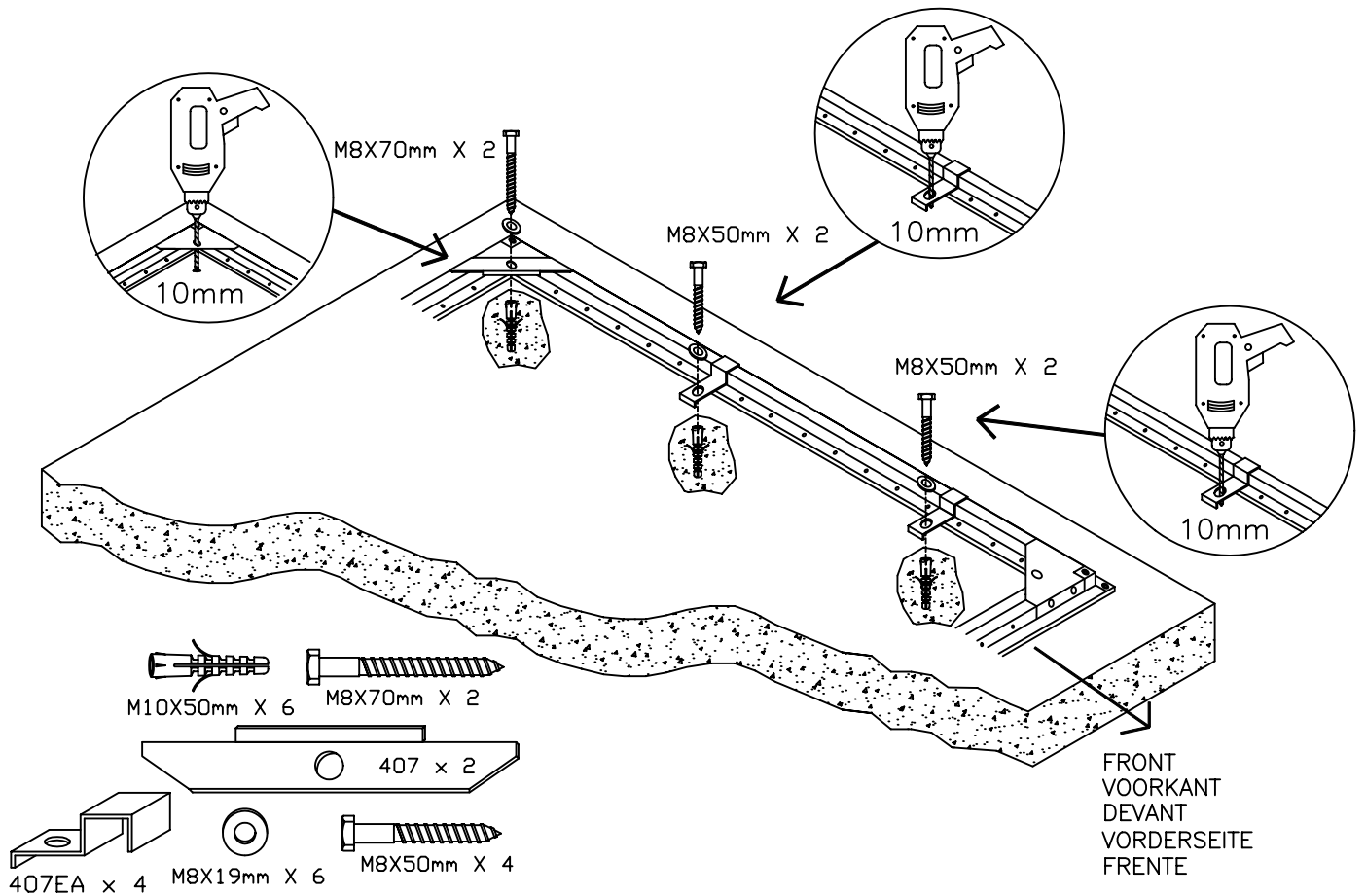

- BAG NO. 5 PLASTIC TIPS USED ON EXPOSED SCREW POINTS ON INSIDE WALLS
- SAC NO. 5 CAPUCHONS EN PLASTIQUE POUR POINTES DE VIS NUES SUR LES PAROIS INTERIEURES
- BEUTEL NO. 5 PLASTIK-AUFSTECKHUTCHEN FUR DIE SCHRAUBENSPIZEN AN DEN INNENWANDEN
- ZAK NO. 5 PLASTIC DOPJES VOOR SCHROEFUITEINDEN AAN DE BINNENWAND
- BOLSA NO. 5 TAPONES DE PLASTICO PARA UTILIZAR EN PUNTOS DONDE QUEDE EXPUESTO EL TORNILLO EN LAS PAREDES INTERIORES
- SACO NO. 5 PONTEIRAS PLASTICAS PARA PONTAS DE PARAFUSOS EXPOSTAS NAS PAREDES INTERIORES