

EN OWNER'S MANUAL /

Instructions for Assembly '10 Ft Top'
Size 10Ft x 8Ft / 3.2 m x 2.4 m
Ver: 0.0

FR MANUEL D'INSTRUCTION/

Instructions pour l'Assemblage '10 Pieds Top'
Dimension 10Pieds x 8Pieds / 3.2 Mètre x 2.4 Mètre
Ver: 0.0

DE Benutzerhandbuch /

Montageanleitung '10 Ft Top'
Größe: 10Ft x 8Ft / 3.2 m x 2.4 m
Ver: 0.0

ES MANUAL DE USO /

Instrucciones de montaje '10 Pies Top'
Tamaño 10Pies x 8Pies / 3.2 Metros x 2.4 Metros
Ver: 0.0

PT MANUAL DO PROPRIETARIO/

Instruções de montagem '10 pés Top'
Tamanho 10pés x 8pés / 3.2 Metro x 2.4 Metro
Ver:0.0

NL Gebruiksaanwijzing voor eigenaar/

Instructies voor bouw '10Voet Top'
Maat 10 voet x 8 voet / 3.2 Meter x 2.4 Meter
Versie: 0.0

CS Příručka uživatele /

Návod k montáži '10 Stopy Top'
Velikost 10 Stopy x 8 Stopy / 3.2 Metr x 2.4 Metr
Verze : 0.0

SK NÁVOD PRE UŽÍVATEĽA /

Návod na zloženie '10 Stopa Top'
Velkost' 10Stopa x 8Stopa / 3.2 m x 2.4 m
Pozri: 0.0

SL PRIROČNIK ZA LASTNIKA

Navodila za montažo '10 Čevljev Top'
Velikost 10Čevljev x 8Čevljev / 3.2 Metrov x 2.4 Metrov
Razl: 0.0

HR Gazdinski Priručnik /

Instrukcije za skupštine '10 Stopalo Top'
Veličina 10 Stopalo x 8 Stopalo/ 3.2 Metar x 2.4 Metar
Ver: 0.0

HU FELHASZNÁLÓI KÉZIKÖNYV /

Útmutató az összeszereléshez '10 Láb Top'
10Láb x 8Láb / 3.2 Méter x 2.4 Méter
0.0 verzió

SV ÄGARENS MANUAL/

Monteringsinstruktioner för '10 Fot Top'
Storlek 10 fot x 8 fot / 3.2 m x 2.4 m
Version: 0.0

IT MANUALE DEL PROPRIETARIO /

Istruzioni per l'assemblaggio '10 Piedi Top'
Dimensione 10 Piedi x 8 Piedi / 3.2Metri x 2.4Metri
Versione 0.0

PL PODRĘCZNIK UŻYTKOWNIKA /

Instrukcja montażu '10Stopy Top'
Wymiary 10Stopy x 8Stopy / 3.2 Metr x 2.4 Metr
Wersja: 0.0

RO MANUAL DE UTILIZARE /

Instrucțiuni de asamblare '10 Picioare Top'
Mărimē 10Picioare x 8Picioare / 3.2 Metri x 2.4 Metri
Ver: 0.0

BG РЪКОВОДСТВО ЗА ПРИТЕЖАТЕЛЯ /

Инструкции за сглобяване '10 Фута Top'
Размер 10 Фута x 8 Фута / 3.2 Метра x 2.4 Метра
Версия: 0.0

TR KULLANIM KILAVUZU /

Montaj Talimatları '10 Fit Top'
10Fit x 8Fit / 3.2 m x 2.4m
Sürüm: 0.0

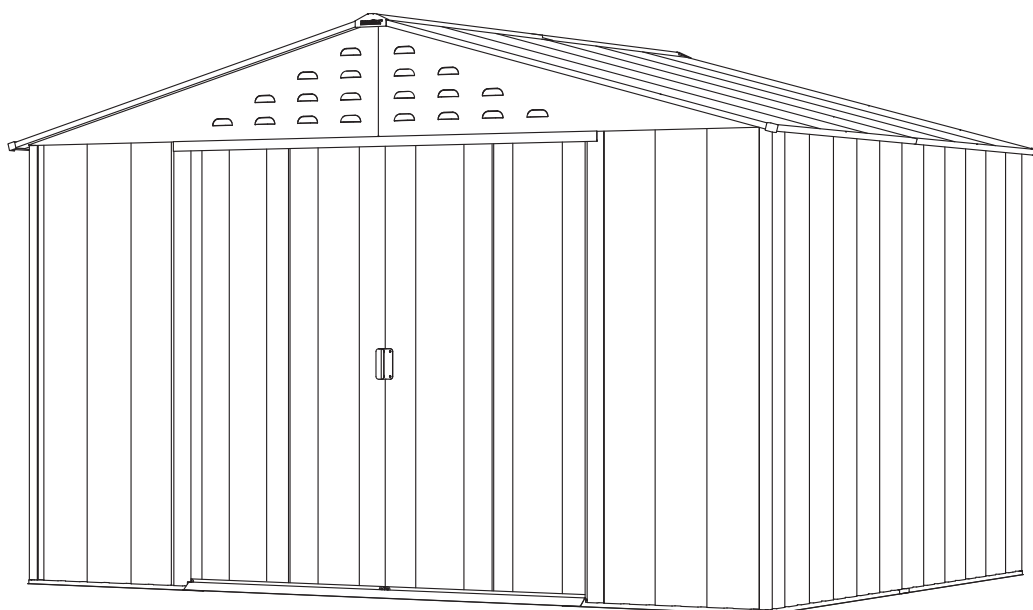
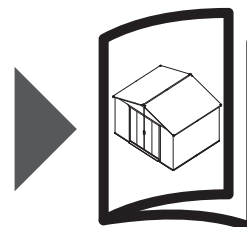

EN

Building Dimensions :

Approximate Size	Storage		Exterior Dimension				Interior Dimension		Door Opening		
	Area	Volume	Base Dimension		Roof Edge to Edge		Wall to Wall				
			inch	cm	inch	cm	inch	cm	inch	cm	
10 Ft x 8 Ft	84 1/4 Sq. Ft	491 5/8 Cu.Ft	Width	122 3/4	311.9	126 5/8	321.8	119 1/2	303.6	49	124.5
3.2 m x 2.4 m	7.82 Sq.m	13.92 Cu.m	Depth	91 7/8	233.4	95 3/4	243.3	87 1/8	221.3		
			Height			82 3/8	209.3	70	177.8	68 1/8	173

Snow load tested max. 12lbs/sq.foot (As per IP Standard).

“We recommend to clear snow from the Roof top after each Snowfall.”

A snow depth of more than 10 cm can become hazardous!

FR

Dimensions du bâtiment :

Taille approximative	Stockage		Dimension extérieure				Dimension intérieure		Ouverture de porte		
	Secteur	Volume	Dimension de base		Toit de bord au bord		Mur à mur				
			pouce	cm	pouce	cm	pouce	cm	pouce	cm	
10 Pieds x 8 Pieds	84 1/4 Carré pieds	491 5/8 Pieds cube	Largeur	122 3/4	311.9	126 5/8	321.8	119 1/2	303.6	49	124.5
3.2 Mètre x 2.4 Mètre	7.82 Mètre carré	13.92 Mètre cube	Profondeur	91 7/8	233.4	95 3/4	243.3	87 1/8	221.3		
			Hauteur			82 3/8	209.3	70	177.8	68 1/8	173

Charge de neige testé max. 12lbs/sq.Foot(conformément à la norme IP).

“Nous recommandons d’enlever la neige du Toit après chaque Enneigement.”

Une épaisseur de neige de plus de 10 cm peut devenir dangereux!

DE

Gebäude Abmessung:

Ungefähre Größe	Speicher		Außen Abmessung				Innen Abmessung		Türöffnung		
	Bereich	Volumen	Fundament Abmessung		Dach Kante bis Kante		(von Wand zu Wand)				
			inch	cm	inch	cm	inch	cm	inch	cm	
10 Ft x 8 Ft	84 1/4 Sq. Ft	491 5/8 Cu.Ft	Breite	122 3/4	311.9	126 5/8	321.8	119 1/2	303.6	49	124.5
3.2 m x 2.4 m	7.82 Sq.m	13.92 Cu.m	Tiefe	91 7/8	233.4	95 3/4	243.3	87 1/8	221.3		
			Höhe			82 3/8	209.3	70	177.8	68 1/2	173

Schneelast max. getestet. 12lbs/sq.Foot (gem. Standard IP).

“Wir empfehlen, Schnee von der Dachspitze nach jedem Schneefall zu löschen.”

Eine Schneetiefe von mehr als 10 cm kann gefährlich werden!

ES

Dimensiones del edificio:

El Tamaño a proxímado	Área de almacenaje		Dimensión exterior				Dimensión interior		Abertura de la puerta		
	Área	Volume	Dimensión de la base		Borde de la azotea al borde		pared a pared				
			Pulgada	cm	Pulgada	cm	Pulgada	cm	Pulgada	cm	
10 Pies x 8Pies	84 1/4 Pies cuadrados	491 5/8 Pies Cúbicos	Anchura	122 3/4	311.9	126 5/8	321.8	119 1/2	303.6	49	124.5
3.2 Metros x 2.4 Metros	7.82 Metros cuadrados	13.92 Metros Cúbicos	Profundidad	91 7/8	233.4	95 3/4	243.3	87 1/8	221.3		
			Altura			82 3/8	209.3	70	177.8	68 1/8	173

Carga de nieve probado max. 12LBS/sq.Foot (según el estándar de IP).

“Se recomienda limpiar la nieve de la azotea después de cada nevada.”

Una profundidad de nieve de más de 10 cm puede llegar a ser peligrosa!

PT

Área de Construção:

Dimensão aproximada	Área de Arrumação		Dimensão Exterior				Dimensão Interior		Abertura da Porta		
	Área	Volume	Dimensão da base		Amplitude do Telhado		(Parede a Parede)				
			Polegada	centímetro	Polegada	centímetro	Polegada	centímetro	Polegada	centímetro	
10 pés x 8 pés	84 1/4 Pies quadrado	491 5/8 Pies cúbico	Comprimento	122 3/4	311.9	126 5/8	321.8	119 1/2	303.6	49	124.5
3.2 Metro x 2.4 Metro	7.82 Metro quadrado	13.92 Metro cúbico	Profundidade	91 7/8	233.4	95 3/4	243.3	87 1/8	221.3		
			Altura			82 3/8	209.3	70	177.8	68 1/8	173

Carga de neve testado max. 12lbs/sq.Foot (conforme padrão IP).

“Recomendamos limpar a neve do topo do telhado após cada queda de neve.”

Uma profundidade de neve de mais de 10 cm pode tornar-se perigosa!

NL

Gebouw afmeting:

Benadering Maat	Opslag		Buitenkant afmeting				Binnenkant afmeting		Deur opening		
	Gebied	Volume	Basis afmeting		Dakrand tot rand		Muur tot muur		inch	cm	
			inch	cm	inch	cm	inch	cm			
10 Voet x 8 Voet	84 1/4 Vierkante voet	491 5/8 Kubieke voet	Wijdte	122 3/4	311.9	126 5/8	321.8	119 1/2	303.6	49	124.5
3.2 m x 2.4 m	7.82 Vierkante meter	13.92 Kubieke meter	Diepte	91 7/8	233.4	95 3/4	243.3	87 1/8	221.3		
			Hoogte			82 3/8	209.3	70	177.8	68 1/8	173

Sneeuw belasting getest max. 12lbs/sq.Foot (volgens het standaard IP-).
 “We raden aan sneeuw uit het dak te verwijderen na elke sneeuwval.”
 Een sneeuwdiepte van meer dan 10 cm kan gevaarlijk worden!

CS

Budova rozměr

Přibližné rozměry	Skladování		Vnější rozměr				Vnitřní rozměr		Otevírání dveří		
	Plocha	Objem	Základní rozměr		Na okraj střechy edge		zdi ke zdi		inch	cm	
			inch	cm	inch	cm	inch	cm			
10 Stopy x 8 Stopy	84 1/4 Čtvereční Stopy	491 5/8 Krychlový Stopy	Šířka	122 3/4	311.9	126 5/8	321.8	119 1/2	303.6	49	124.5
3.2 Metr x 2.4 Metr	7.82 Čtvereční metr	13.92 Krychlový Metr	Hĺoubka	91 7/8	233.4	95 3/4	243.3	87 1/8	221.3		
			Výška			82 3/8	209.3	70	177.8	68 1/8	173

Zkouška zatížení sněhu max. 12 lbs / sq.foot (podle normy IP).
 “Doporučujeme odstranit sníh ze střešního krytu po každém sněžení.”
 Možná hloubka sněhu větší než 10 cm může být nebezpečná!

SK

Stavebné rozmer

Približné veľkosti	Sklad		Vonkajší rozmer				Interiér rozmer		Otvorenie dverí		
	Priestor	Objem	Base rozmer		Strešné okraja k okraju		Zdi k múru		inch	cm	
			inch	cm	inch	cm	inch	cm			
10 Stopa x 8 Stopa	84 1/4 Stopa štvorcový	491 5/8 Stopa kubický	Šírka	122 3/4	311.9	126 5/8	321.8	119 1/2	303.6	49	124.5
3.2 m x 2.4 m	7.82 Meter štvorcový	13.92 Meter kubický	Hĺbka	91 7/8	233.4	95 3/4	243.3	87 1/8	221.3		
			Výška			82 3/8	209.3	70	177.8	68 1/8	173

Testovanie zaťaženia snehu max. 12 libier / sq.foot (podľa IP štandardu).
 “Odporúčame odstrániť sneh zo strechy po každej snehu.”
 Z hĺbky snehu väčšej ako 10 cm sa môže stať nebezpečné!

SL

Zidanje obseg

približno velikost	Skladiščenje		zunanji obseg				notranji obseg		vrata predrtina		
	Območje	Prostornina	osnova obseg		streha rob v rob		obdati obzidati		cola	cm	
			cola	cm	cola	cm	cola	cm			
10 Čevljev x 8 Čevljev	84 1/4 Kvadratnih Čevljev	491 5/8 Kubičnih Čevljev	širina	122 3/4	311.9	126 5/8	321.8	119 1/2	303.6	49	124.5
3.2 Metrov x 2.4 Metrov	7.82 Kvadratnih Metrov	13.92 Kubičnih Metrov	globina	91 7/8	233.4	95 3/4	243.3	87 1/8	221.3		
			višina			82 3/8	209.3	70	177.8	68 1/8	173

Snow obremenitev testiran max. 12lbs / sq.foot (po standardu IP).
 “Priporočamo, da počistite sneg z vrha strehe po vsakem sneženju.”
 Z globino snega več kot 10 cm lahko postane nevarno!

HR

Zgrada dimenzija

Približno određena mjera	Skladištenje		Vanjski dimenzija				Interijer dimenzija		Vrata Open		
	Područje	Svezak	Temeljiti dimenzija		Krov rub to rub		Zidni to zidni				
			inch	cm	inch	cm	inch	cm	inch	cm	
10 Stopalo x 8 Stopalo	84 1/4 Četvornih Stopalo	491 5/8 Kubni Stopalo	širina	122 3/4	311.9	126 5/8	321.8	119 1/2	303.6	49	124.5
3.2 Metar x 2.4 Metar	7.82 Četvornih Metar	13.92 Kubni Metar	dubina	91 7/8	233.4	95 3/4	243.3	87 1/8	221.3		
			visina			82 3/8	209.3	70	177.8	68 1/8	173

Testirano opterećenje max. 12 lbs / sq.foot (prema IP standardu).
 “Preporučujemo čišćenje snijega s vrha krova nakon svakog snijega.”
 Nema dubine snijega veće od 10 cm može biti opasna!

HU

Építési dimenzió

Hozzávetőleges mérete	Tárolás		Külső méret				A belső dimenzió		Ajtónyitás		
	Terület	Mennyiség	Alap dimenzió		Tető élétől él		A fal és a fal				
			Hüvelyk	cm	Hüvelyk	cm	Hüvelyk	cm	Hüvelyk	cm	
10 Láb x 8 Láb	84 1/4 Négyzet Láb	491 5/8 Kőb Láb	Szélesség	122 3/4	311.9	126 5/8	321.8	119 1/2	303.6	49	124.5
3.2 Méter x 2.4 Méter	7.82 Négyzet méter	13.92 Kőbméter	Oldalmagasság	91 7/8	233.4	95 3/4	243.3	87 1/8	221.3		
			Magasság			82 3/8	209.3	70	177.8	68 1/8	173

A terhelés max. 12 lbs / négyzetméter (IP-szabvány szerint).
 “Javasoljuk, hogy minden hóesést követően tisztítsa meg a havat a tetőtől.”
 A 10 cm-nél hosszabb hóvastagság veszélyessé válhat!

SV

Byggnadsdimensioner:

Ungefärlig storlek	Lager		Yttre dimensioner				Inre dimensioner		Dörröppning		
	Area	Volym	Basdimensioner		Tak kant till kant		Vägg till vägg				
			Tum	cm	Tum	cm	Tum	cm	Tum	cm	
10 fot x 8 fot	84 1/4 kvadrat fot	491 5/8 kubik fot	Bredd	122 3/4	311.9	126 5/8	321.8	119 1/2	303.6	49	124.5
3.2 m x 2.4 m	7.82 kvadratmeter	13.92 kubik meter	Djup	91 7/8	233.4	95 3/4	243.3	87 1/8	221.3		
			Höjd			82 3/8	209.3	70	177.8	68 1/8	173

Snow last testas max. 12 kg / kvadratfot (enligt IP-standard).
 “Vi rekommenderar att klara snö från taket efter varje snöfall.”
 Ett snödjup på mer än 10 cm kan bli farligt!

IT

Dimensioni di Costruzione:

Dimensione approssimativa	Deposito		Dimensione Esterna				Dimensioni Interne		Apertura della Porta		
	Area	Volume	Dimensione della Base		Soffitto da Lato a Lato		Da Muro a Muro				
			Inches	Centimetri	Inches	Centimetri	Inches	Centimetri	Inches	Centimetri	
10 Piedi x 8 Piedi	84 1/4 Piedi Quadrati	491 5/8 Piedi Cubici	Ampiezza	122 3/4	311.9	126 5/8	321.8	119 1/2	303.6	49	124.5
3.2 Metri x 2.4 Metri	7.82 Metri Quadrati	13.92 Metri Cubici	Profondità	91 7/8	233.4	95 3/4	243.3	87 1/8	221.3		
			Altezza			82 3/8	209.3	70	177.8	68 1/8	173

Snow carico testato max. 12 lbs / sq.foot (come per IP standard).
 “We consigliamo di eliminare la neve dalla tetto del tetto dopo ogni nevicata.”
 Una profondità di neve di oltre 10 cm può diventare pericolosa!

PL

Wymiary budowlane:

Przybliżone wymiary	Magazynowa		Wymiary zewnętrzne				Wymiary wewnętrzne		Otwieranie drzwi		
	Powierzchnia	Kubatura	Wymiary fundamentów		Dachu od krawędzi do krawędzi		od ściany do ściany				
			Cal	cm	inch	cm	inch	cm	inch	cm	
10 Stopy x 8 Stopy	84 1/4 Stopy kwadratowy	491 5/8 Stopy sześcienny	Szerokość	122 3/4	311.9	126 5/8	321.8	119 1/2	303.6	49	124.5
3.2 Metr x 2.4 Metr	7.82 Metr kwadratowy	13.92 Metr sześcienny	Głębokość	91 7/8	233.4	95 3/4	243.3	87 1/8	221.3		
			Wysokość			82 3/8	209.3	70	177.8	68 1/8	173

Obciążenia śniegiem testowałem max. 12lbs/sq.Foot (jak na IP Standard).

“Zalecamy wyczyszczenie śniegu z dachu dachu po każdym śniegu.”

Możliwość śniegu powyżej 10 cm może stać się niebezpieczna!

RO

Cladirea dimensiuni

Dimensiunea aproximativa	Depozitarea		Dimensiunea exterioara				Dimensiunea interne		deschiderea usii		
	Suprafata	Volumul	Baza dimensiuni		Acoperisul marginea la marginea		perete in perete				
			inch	cm	inch	cm	inch	cm	inch	cm	
10 Picioare x 8 Picioare	84 1/4 Picioare pătrați	491 5/8 Picioare cubi	Latimea	122 3/4	311.9	126 5/8	321.8	119 1/2	303.6	49	124.5
3.2 Metri x 2.4 Metri	7.82 Metri pătrați	13.92 Metri cubi	Adancimea	91 7/8	233.4	95 3/4	243.3	87 1/8	221.3		
			Inaltimea			82 3/8	209.3	70	177.8	68 1/8	173

Rezultatea de încărcare maximă testată. 12 lbs / sq.foot (conform standardului IP).

“Vă recomandăm să eliminați zăpada din partea superioară a acoperișului după fiecare zăpadă.”

O adâncime de zăpadă mai mare de 10 cm poate deveni periculoasă!

BG

Сградата измерение

Ориентировачна размер	Съхранение		Външно измерение				Министърът на вътрешните измерение		Вратата отваряне		
	Площ	Обем	База измерение		Покрив край до край		Стената на стената				
			Инча	Сантиметра	Инча	Сантиметра	Инча	Сантиметра	Инча	Сантиметра	
10 Фута x 8 Фута	84 1/4 Квадратни Фута	491 5/8 Кубични Фута	Ширина	122 3/4	311.9	126 5/8	321.8	119 1/2	303.6	49	124.5
3.2 Метра x 2.4 Метра	7.82 Квадратни Метра	13.92 Кубични Метра	Дълбочина	91 7/8	233.4	95 3/4	243.3	87 1/8	221.3		
			Височина			82 3/8	209.3	70	177.8	68 1/8	173

Тестване на тежестта на снемане макс. 12 кг / кв. Фут (според IP Стандарт).

“След всеки снеговалеж препоръчваме да изчистите снега от покрива на покрива.”

Дълбочина на снега повече от 10 см може да стане опасна!

TR

İnşaat boyutu

Tahmini büyüklüğü	Depo		Dış boyutlar				İç boyutu		Kapı açılması		
	Alan	Hacim	Temel boyutundaki		sertliği için harekete		Duvardan duvara				
			İnç	Sanтимetre	İnç	Sanтимetre	İnç	Sanтимetre	İnç	Sanтимetre	
10 Fit x 8 Fit	84 1/4 Metre Fit	491 5/8 Kübik Fit	Genişlik	122 3/4	311.9	126 5/8	321.8	119 1/2	303.6	49	124.5
3.2 m x 2.4 m	7.82 Metrekare	13.92 Kübik metre	Derinlik	91 7/8	233.4	95 3/4	243.3	87 1/8	221.3		
			Yükseklik			82 3/8	209.3	70	177.8	68 1/8	173

Saat yükü test max. 12lbs / sq.foot (IP Standardına göre).

“Her Kar yağışı sonrasında Çatı üstten kar temizlemenizi öneririz.”

Kar derinliği 10 cm'den fazla tehlikeli olabilir!

EN Tools You Will Need

- | | |
|----------------------------------|---------------------|
| 1. Cordless Drill - Philips Head | 6. Tape Measure |
| 2. Screwdriver - Philips Head | 7. Hand Gloves |
| 3. Carpenters Square | 8. Eye Protector |
| 4. 8' Step Ladder | 9. Box Spanner-7 mm |
| 5. Level - 3ft. | |

FR Outils dont vous aurez besoin

- | | |
|-------------------------------------|--------------------------------|
| 1. Perceuse sans fil – Tête Philips | 6. Ruban à mesurer |
| 2. Tournevis - Tête Philips | 7. Gants |
| 3. Équerre du Menuisier | 8. Protecteur des Yeux |
| 4. Escabeau 8' | 9. Clé de serrage de boîte-7mm |
| 5. Niveau - 3ft. | |

DE Benötigte Werkzeuge

- | | |
|---|------------------------|
| 1. Akku-Bohrschrauber - Kreuzschlitzbit | 6. Maßband |
| 2. Kreuzschlitz-Schraubenzieher | 7. Handschuhe |
| 3. Winkelmaß | 8. Schutzbrille |
| 4. 8' Leiter | 9. Kasten- |
| 5. Wasserwaage – 1 m | Schraubenschlüssel-7mm |

ES Equipar con herramienta Usted Necesitará

- | | |
|---|--------------------------------|
| 1. Taladro inalámbrico - cabeza Philips | 6. Cinta métrica |
| 2. Destornillador - cabeza Philips | 7. Guantes de la mano |
| 3. Carpinteros Plaza | 8. Protector de Ojo |
| 4. Escalera de 8' | 9. Llave de tuerca de caja-7mm |
| 5. Nivelan - 3ft. | |

PT Ferramentas que irá precisar

- | | |
|------------------------------------|-----------------------------------|
| 1. Cordless Berbequim | 6. Fita Métrica |
| 2. Chave de fenda – cabeça estrela | 7. Luvas |
| 3. Esquadro de carpinteiro | 8. Protector Ocular |
| 4. Escadote 8" | 9. Chave de parafuso de caixa-7mm |
| 5. 3ft. Nivel | |

NL Gereedschappen die u nodig zult hebben

- | | |
|---|--------------------|
| 1. Snoerloze boormachine met gekruiste kop | 6. Meetlint |
| 2. Snoerloze schroevendraaier met gekruiste kop | 7. Handschoenen |
| 3. Winkelhaak | 8. Oogbescherming |
| 4. Ladder met acht treden | 9. Vak spanner-7mm |
| 5. Waterpas | |

CS Budete potřebovat toto nářadí

- | | |
|---------------------------------|--------------------------|
| 1. Bezdrátová vrtačka - Philips | 6. Svinovací metr |
| 2. Vrták - Philips | 7. Rukavice |
| 3. Tesařské náměstí | 8. Ochranné brýle |
| 4. 8mí stupňový žebřík | 9. Krabicový klíč - 7 mm |
| 5. Vodováha - 3ft. | |

SK Nástroje, ktoré budete potrebovať

- | | |
|--------------------------------------|----------------------|
| 1. Bezdrôtová vrtačka - Philips Head | 6. Meter |
| 2. Šraubovák – Philips Head | 7. Rukavice |
| 3. Stolársky meter | 8. Ochranu na oči |
| 4. 8' Rebrík | 9. Kľúčový kľúč 7 mm |
| 5. Zdvihák – 3 stopy. | |

SL Orodje, ki ga boste potrebovali

- | | |
|------------------------------------|--------------------|
| 1. Brezžična vrtalna- glava Philip | 6. Merilni trak |
| 2. Vijačnik-glava Philip | 7. Rokavice |
| 3. Mizarski kvadrat | 8. zaščitna očala |
| 4. 2438,4 mm dvokraka lestev | 9. Polje kľuč-7 mm |
| 5. Nivelirka - 0,91 m | |

HR Alati, Trebat će Vam

- | | |
|--------------------------------------|------------------------------|
| 1. Bežični Svrđlo – Philips Voditelj | 6. Traka Divizor |
| 2. Vijak Vozač - Philips Voditelj | 7. Ručni Rukavice |
| 3. Drvodjelac Četverokut | 8. Oko Zaštitnik |
| 4. 8' Korak Ljestve | 9. Kutija za ključeve - 7 mm |
| 5. Razina – 3 stoplo. | |

HU A szükséges szerszámok

- | | |
|---------------------------------------|------------------|
| 1. Vezeték nélküli fúró – csillagfejű | 6. Mérőszalag |
| 2. Csavarhúzó – csillagfejű | 7. Kesztyűk |
| 3. Ácsderékszög | 8. Szemvédő |
| 4. 8-fokú létra | 9. Csőkulcs-7 mm |
| 5. Vízszintmérő. | |

SV Verktyg du kommer att behöva

- | | |
|--------------------------------------|------------------------|
| 1. Sladdlös bormaskin - Philips borr | 6. Måttband |
| 2. Skruvmejsel - krysshuvud | 7. Verktygshandskar |
| 3. Vinkelhake | 8. Ögonskydd |
| 4. 8-fots stege | 9. Box skiftnyckel-7mm |
| 5. vattenmått - 3fot. | |

IT Gli Attrezzi di cui Avrai Bisogno

- | | |
|--|-----------------------------|
| 1. Trapano senza fili – Punta a stella | 6. Metro a Nastro |
| 2. Cacciavite – Punta a stella | 7. Guanti |
| 3. Squadra metallica | 8. Protezione per gli occhi |
| 4. Scala ad 8 pioli | 9. Chiave a tubo - 7mm |
| 5. Livello – 3 piedi | |

PL Potrzebne narzędzia

- | | |
|---|----------------------|
| 1. Bezprzewodowa wkrętarka – krzyżakowa | 6. Taśma miernicza |
| 2. Śrubokręt krzyżakowy | 7. Rękawice ochronne |
| 3. Kałownik stolarski | 8. Okulary ochronne |
| 4. 8' Drabina składana | 9. Klucz-Box 7mm |
| 5. Poziomica – 91,4 cm | |

RO Instrumentele de care aveți nevoie

- | | |
|-------------------------------------|--------------------------|
| 1. Șurubelniță – cap Philips | 6. Ruletă de măsurat |
| 2. Mașină de găurit – cap Philips | 7. Mănuși de protecție |
| 3. Echer de dulgherie | 8. Protecție pentru ochi |
| 4. Scară cu trepte de 8' (20.32 cm) | 9. Caseta Spanner-7mm |
| 5. Nivel - 3ft. | |

BG Инструменти, които ще ви трябват

- | | |
|---|------------------------|
| 1. Безжична бормашина - с глава Philips | 6. Рулетка |
| 2. Отвертка – с глава Philips | 7. Ръкавици |
| 3. Прав ъгъл | 8. Маска за очите |
| 4. Стълба – 20 см (8') | 9. Гаечная коробка-7mm |
| 5. Нивелир – 1 м (3ft). | |

TR İhtiyaç duyacağınız aletler

- | | |
|------------------------------------|------------------------|
| 1. Kablosuz Matkap- Philips Başlık | 6. Mezura |
| 2. Tornavida-Philips Başlık | 7. Eldiven |
| 3. Marangoz gönyesi | 8. Göz Koruyucu |
| 4. 8 Basamaklı Merdiven | 9. Geçme Anahtar – 7mm |
| 5. Seviye- 91,5 cm. | |

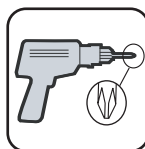

1

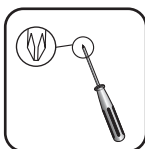

2



3



4

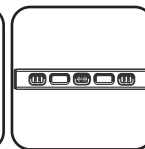

5

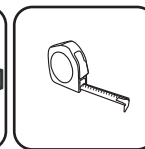

6

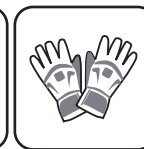

7



8

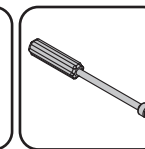

9

EN Parts List

FR Liste des pièces

DE Teileliste

ES La Lista de Partes

PT Lista de Peças

NL Onderdelenlijst

CS Seznam součástí

SK Zoznam častí

SL Seznam delov

HR Dijelovi Lists

HU Alkatrésztlista

SV Komponentlista

IT Lista delle varie parti

PL Lista części

RO Lista elementelor componente

BG Списък на частите

TR Parça Listesi

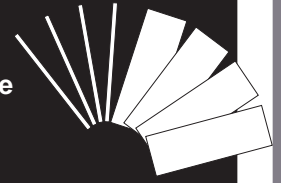

- EN**
1. Check all parts prior to installation.
 2. Use screws with plastic washers on top of prepainted surface only.
 3. Before starting installation, please refer Safety & Precautions.

- FR**
1. Vérifier toutes les pièces avant l'installation.
 2. Utilisez des vis avec des rondelles en plastique sur le dessus de la surface pré peinte seulement.
 3. Avant de commencer l'installation, référez-vous svp à Sécurité et Précautions.

- DE**
1. Prüfen Sie alle Teile vor der Montage.
 2. Benutzen Sie bei lackierten Oberflächen nur Schrauben mit Plastikunterlegscheiben.
 3. Lesen Sie vor dem Aufbau die Sicherheitsanweisungen.

- ES**
1. Verifica todo despide antes de instalación.
 2. Use los tornillos con las arandelas plásticas encima pre pintadas en la superficie solamente.
 3. Antes de comenzar la instalación, consulte Seguridad y Precauciones.

- PT**
1. Confirme todas as peças antes da instalação.
 2. Utilize parafusos com anilhas plásticas em cima da superfície prepainted apenas.
 3. Antes de iniciar a instalação, cheque item "Segurança e Cuidados".

- NL**
1. Controleer vooraf of alle onderdelen aanwezig zijn.
 2. Gebruik schroeven met plasticen ring aan de bovenkant of voor gelakt ondergrond.
 3. Voordat u begint met installeren, verwijzing naar veiligheid voorschriften.

- CS**
1. Něž začnete s montáží, zkontrolujte všechny součásti.
 2. Používejte šrouby z plastovým těsněním pouze na natřenou plochu.
 3. Před montáží si prosím přečtěte Bezpečnost a bezpečnostní opatření.

- SK**
1. Skontrolujte všetky časti pred inštaláciou.
 2. Použite skrutky s plastovými podložkami len na natretej ploche.
 3. Skôr ako začnete s inštaláciou, prečítajte si Bezpečnosť a bezpečnostné opatrenia.

- SL**
1. Pred montažo preverite vse dele.
 2. Uporabite vijake s plastičnimi podložkami samo na vrhu grundirane površine.
 3. Pred začetkom namestitve, glejte VARNOST & VARNOSTNI UKREPI.

- HR**
1. Provjera svih dijelova prije instalacije.
 2. Koristite vijaka sa plastičnim podmetakima na vrhu od unaprijed obojana površina.
 3. Prije nego Vi počnete instalacija, molim vas pogledajte Sigurnost i mjere opreza

- HU**
1. Ellenőrizzen minden alkatrészt az összeszerelés megkezdése előtt.
 2. Előre festett felületeken csak műanyag alátétekkel használja a csavarokat.
 3. Az összeszerelés megkezdése előtt kérjük vegye figyelembe a biztonsági utasításokat.

- SV**
1. Kolla alla delar före installationen.
 2. Använd skruvar med plastbrickor bara på målade ytor.
 3. innan man startar installationen ska man läsa igenom säkerhet & försiktighetsåtgärder.

- IT**
1. Controlla tutte le parti prima dell'installazione.
 2. Usa viti con rondelle di plastica sulla parte superiore delle superfici preverniciate.
 3. Prima di incominciare con l'installazione, per favore leggi attentamente I punti illustrati nel paragrafo Sicurezza ed Installazione.

- PL**
1. Sprawdź wszystkie części zanim przystąpisz do montażu.
 2. Używaj śrub z plastikowymi uszczelkami wyłącznie na wcześniej pomalowanej powierzchni.
 3. Przed rozpoczęciem instalacji należy przeczytać rozdział Bezpieczeństwo i środki ostrożności.

- RO**
1. Verificați toate părțile componente înainte de instalare.
 2. Folosiți șuruburi cu șaibe de plastic doar pe suprafața prevopsită.
 3. Înainte de a începe asamblarea, consultați capitolul. Măsuri de siguranță și protecție.

- BG**
1. Проверете всички части преди монтажа.
 2. Използвайте винтове с пластмасови шайби само върху предварително боядисани повърхности.
 3. Преди започване на монтажа, моля разгледайте Безопасност и Защита.

- TR**
1. Kurulumdan önce tüm parçaları kontrol ediniz.
 2. Önceden boyanmış yüzey için sadece Vida ve plastik pul kullanınız.
 3. Montaja başlamadan önce lütfen Güvenlik ve Önlemler kısmına bakınız.





	MA01	1
	MA02	1
	MA03	2
	MA04	2
	MA05	2
	MA06	1
	MA07	4
	ME01	1
	ME02	1
	MA10	1
	MA11	1
	MA12	1
	MA13	1
	MA14	1
	ME20	2
	ME21	2
	MA26	4
	ME03	2
	ME04	2
	ME14	1
	ME05	2
	ME06	2
	ME07	2
	ME08	1
	ME09	1
	ME10	3
	ME11	2
	ME12	1
	ME13	1
	MA18	2
	ME15	2
	ME16	4
	ME17	4
	ME18	2
	ME19	2
	ME22	2

	ME23	1
	ME24	1
	MA30	1
	MA31	1
	MA32	2
	ME25	2
	ME26	2
	ME27	4
	ME28	9
	ME29	2
	ME30	2
	ME31	2
	ME32	4
	ME33	2
	ME34	1
	ME36	1
	ME35	1
	ME37	1

	TC	4
	MA47	4
	MA48	8
	MA49	2
	PW	4Slab
	PC	6Slab
	WST	3.4 Mtr
	F1	28
	S1	390
	S2	74
	S8	28
	S3	80

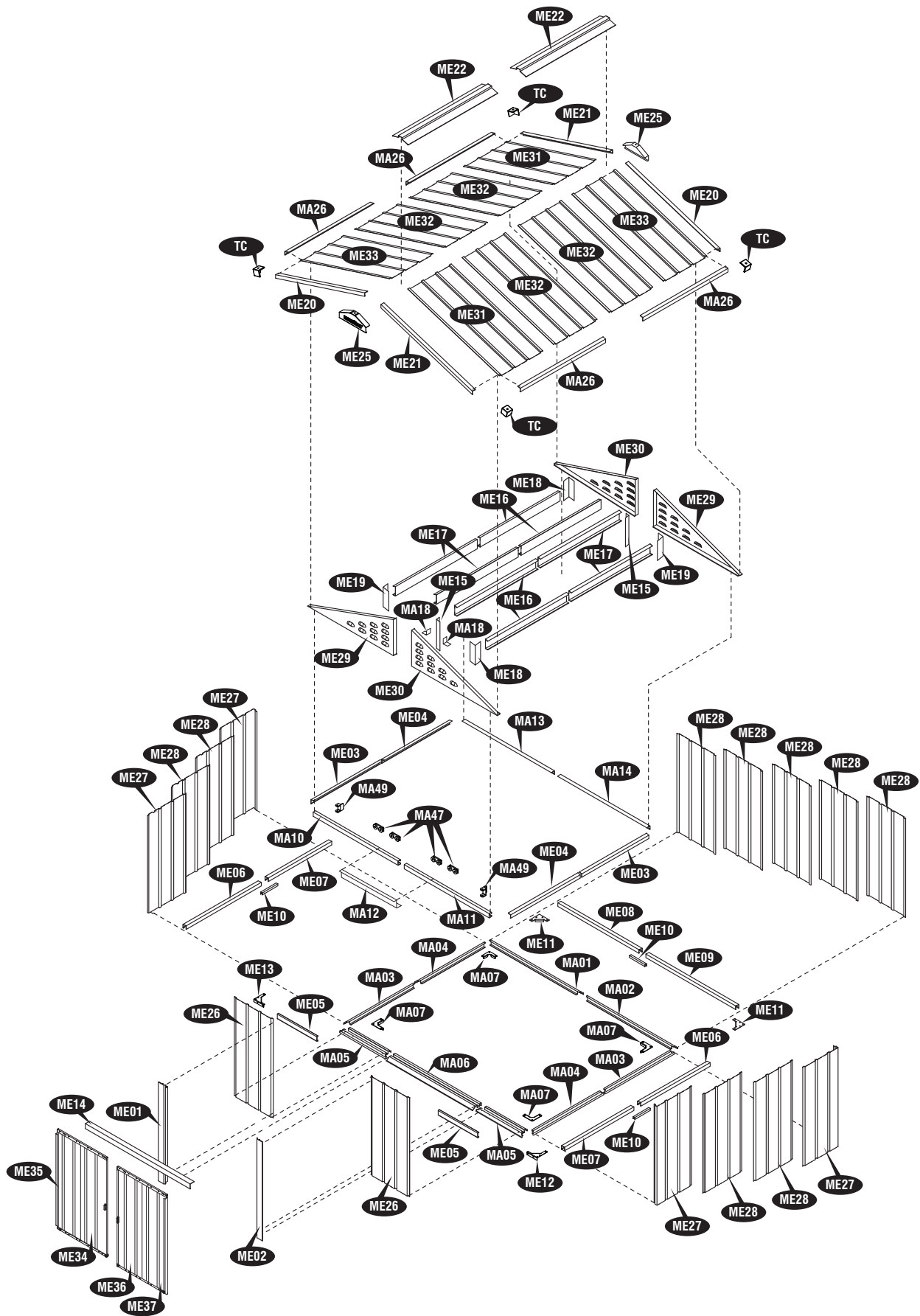



-  **1** → #28-32
- 2** → # 33-52
- 3** → # 53-68
- 4** → # 69-74

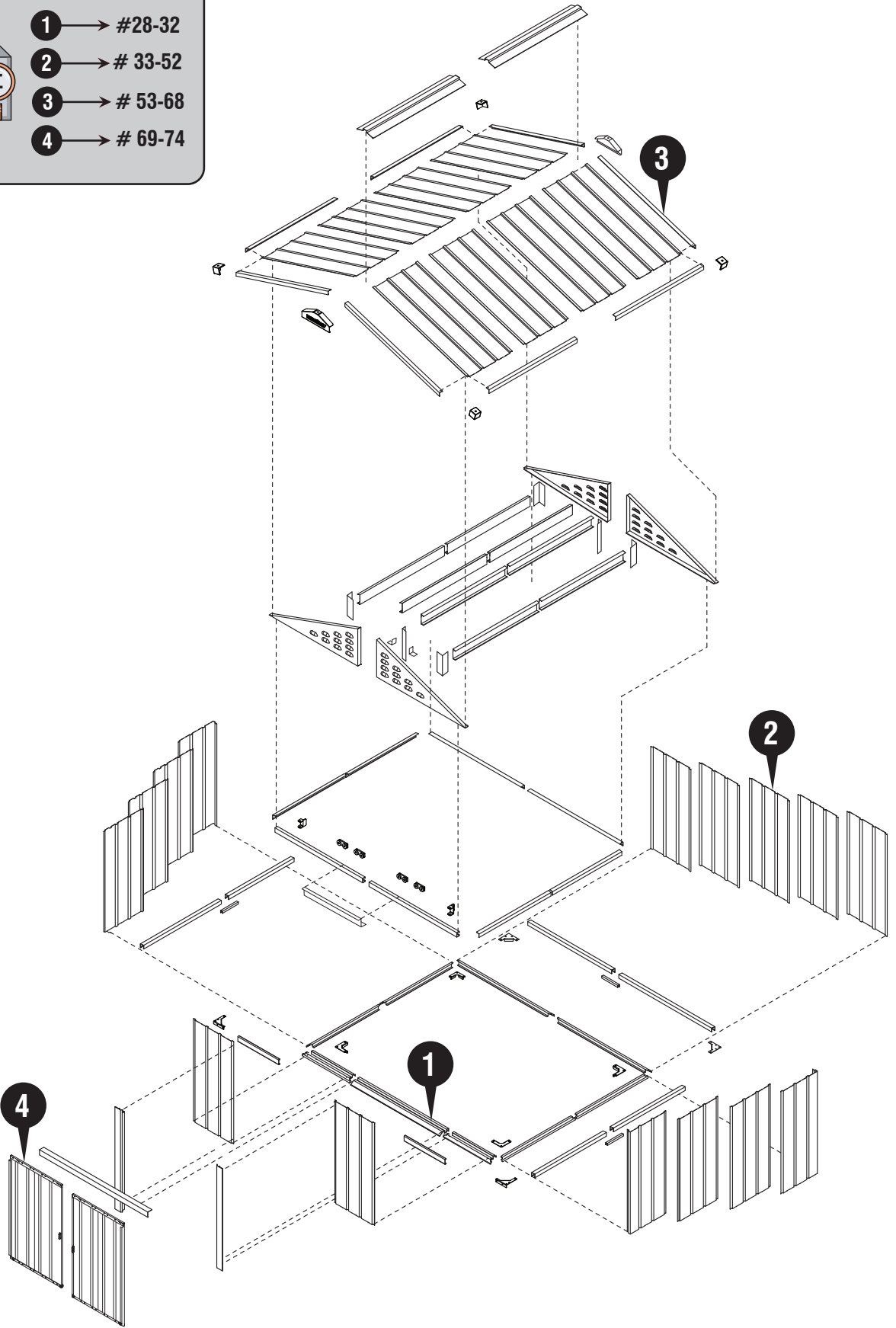



EN Foundation	CS Základy	IT Fondamenta
FR Fondation	SK Základ	PL Podstawa
DE Fundament	SL Temelj	RO Fundația
ES La base	HR Temelj	BG Фундамент
PT Fundação	HU Alap	TR Temel
NL Fundering	SV Grunden	

- (EN) DuraMax must be installed on a DuraMax Foundation, level wooden platform or a level concrete foundation.
(FR) Duramax doit être installé sur une fondation Duramax, une plate-forme en bois de niveau ou une fondation en béton de niveau
(DE) Duramax muss auf einem Duramax Fundament, einer ebenen Holzplattform oder einem ebenen Betonfundament installiert werden
(ES) Duramax debe instalarse sobre una base Duramax, una plataforma de madera nivelada o una base de hormigón nivelada.
(PT) Duramax deve ser instalado em uma base Duramax, plataforma de madeira de nível ou uma base de concreto nivelada.
(NL) Duramax moet geïnstalleerd worden op een Duramax foundation, level houten platform of een betonconcentratie.
(CS) Duramax musí být instalován na základně Duramax, dřevěnou plošinu nebo rovinnou základovou konstrukci.
(SK) Firma Duramax musí byť inštalovaná na základni Duramax, na drevenej plošine alebo na úrovni betónu.
(SL) Duramax mora biti nameščen na temelju Duramax, ravne lesene ploščadi ali ravne betonske podlage
(HR) Duramax mora biti instaliran na temeljima Duramax, drvenoj platformi ili razini konkretnog betona.
(HU) A Duramax-ot Duramax alapra, szintetikus fapadlóra vagy szintetikus betonra kell telepíteni.
(SV) Duramax måste installeras på en Duramax-grund, en plan träplattform eller en jämn betongfundament.
(IT) Duramax deve essere installato su una base Duramax, una piattaforma di legno a livello o una base di calcestruzzo a livello.
(PL) Duramax musi być zainstalowany na fundamencie Duramax, poziomą platformę drewnianą lub poziomą podbudowę betonu.
(RO) Duramax trebuie instalat pe o fundație Duramax, platformă de lemn de nivel sau fundație de beton.
(BG) Duramax трябва да се монтира на основата на Duramax, дървена платформа на нивото или на бетонна основа.
(TR) Duramax, bir Duramax vakfı, düz ahşap platform veya düz bir beton temel üzerine kurulmalıdır.



- (EN) If you have DURAMAX Foundation, please follow instruction manual in that package. If not, follow the below OPTION1 or OPTION 2.
(FR) Si vous avez DURAMAX Foundation, veuillez suivre manuel dans ce paquet. Si non, suivez le ci-dessous OPTION 1 ou OPTION 2.
(DE) Duramax muss auf einem Duramax Stiftung oder ein Niveau hölzernen Plattform oder einem Niveau Betonfundament montiert werden.
(ES) Duramax debe estar instalado en una base Duramax o una plataforma de madera de nivel o una base de hormigón nivelada.
(PT) Duramax deve ser instalado sobre uma base Duramax ou uma plataforma de madeira nível ou uma fundação de concreto nível.
(NL) Duramax moet op een Duramax stichting of een vlakke houten platform of een vlakke betonnen fundering worden geïnstalleerd.
(CS) Pokud máte DURAMAX Foundation, postupujte podle pokynů v tomto balení. Pokud ne, postupujte podle níže uvedených možností OPTION 1 nebo OPTION 2
(SK) Ak máte DURAMAX Foundation, postupujte podľa pokynov v tomto balíku. Ak nie, postupujte podľa nižšie uvedených možností OPTION 1 alebo OPTION 2.
(SL) Če imate DURAMAX Foundation, sledite navodilom v tem paketu. Če ne, sledite spodnjemu OPCIJI 1 ali MOŽNOSTI 2.
(HR) Ako imate DURAMAX Foundation, slijedite upute za uporabu u tom paketu. Ako ne, slijedite dolje OPTION 1 ili OPTION 2.
(HU) Ha rendelkezik DURAMAX Alapítványsal, kérjük, kövesse az adott csomagban található használati utasítást. Ha nem, kövesse az alábbi OPTION 1 vagy OPTION 2 opciókat.
(SV) Om du har DURAMAX Foundation, följ instruktionsboken i det paketet. Om inte, följ följande alternativ 1 eller alternativ 2.
(IT) Se hai la DURAMAX Foundation, segua il manuale di istruzioni in quel pacchetto. In caso contrario, segui la seguente OPZIONE 1 o OPZIONE 2.
(PL) Jeśli masz DURAMAX Fundacji, postępuj zgodnie z instrukcją obsługi w tym pakiecie. Jeśli nie, wykonaj poniżej opcję 1 lub 2 opcję.
(RO) Dacă aveți Fundația DURAMAX, vă rugăm să urmați manualul de instrucțiuni din acel pachet. Dacă nu, urmați OPȚIUNEA 1 sau OPȚIUNEA 2 de mai jos.
(BG) Ако имате DURAMAX Foundation, моля, следвайте инструкциите за употреба в тази опаковка. Ако не, следвайте OPTION 1 или OPTION 2.
(TR) DURAMAX Vakfı'na sahipseniz, lütfen bu pakette yer alan kullanım kılavuzunu izleyin. Değilse, aşağıdaki OPTION 1 veya OPTION 2'yi izleyin.

EN Wooden Platform (Not Included)

FR Plate-forme en bois (non incluse)

DE Holzplattform (nicht im Lieferumfang)

ES La Plataforma de madera (no Incluyó)

PT Plataforma de madeira (Não incluída)

NL Houten platform (niet inbegrepen)

CS Dřevěný základ (není součástí)

SK Drevený podklad (Nedodáva sa)

SL Leseni pod (ni priložen)

HR Drveni platform (Nije Uključena)

HU Fa emelvény (Nem szerepel a csomagban)

SV Träplattform (inte inkluderad)

IT Piattaforma di legno (non incluso)

PL Platforma drewniana (nie objęte)

RO Platformă de lemn (Nu este inclusă)

BG Дървена платформа (Не е включена)

TR Tahta Platform (Pakete dahil değildir)



1

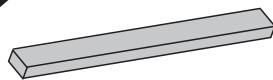

125"x 3 1/2" X 2" (x2)

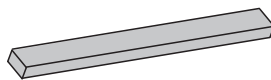

87"x 3 1/2" X 2" (x6)

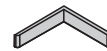

(x4)

(EN) Lay 2 x 4 Flat Pressure Treated Weather proof Wood Studs:
(Actual size 2"x 3 1/2", 50mm x 88.9mm)

(FR) Aire Plate 2" x 4" Pression de l'épreuve des intempéries
traités goujons de bois:
(Taille réelle 2"x 3 1/2", 50mm x 88.9mm)

(DE) 2 x 4 Latten flachlegen Druck behandelt wetterfestes Holz-Stollen
(Aktuelle Größe 2"x 3 1/2", 50 x 88.9)

(ES) Colocar 2 x 4 en llano Presión de prueba del tiempo tratar vigas de madera
(Tamaño real 2"x 3 1/2", 50mm x 88.9mm)

(PT) Deitar 2" x 4"mm Plano Pressão à prova de intempéries tratados
parafusos prisioneiros de madeira:
(tamanho atual 2"x 3 1/2", 50mm x 88.9mm)

(NL) Laag 2 x 4 Vlak Druk behandeld weer bewijs hout hengsten
(Precieze maat 2 x 3 1/2, 50 mm x 88.9 mm)

(CS) Polož 2 x 4 plohy tlak ošetřené počasí proof dřevo hřeby.
(Skutečné velikosti 2" x 3 1/2", 50 x 88.9)

(SK) Plocha 2 x 4 tlak ošetřené počasie dôkaz drevené gombíky.
(Skutočné veľkosti 2" x 3 1/2", 50 x 88.9)

(SL) Položite ravno 2 x 4 pritisk obravnavaajo vreme dokaz lesa klinov
(Dejanska velikost 2"x 3 1/2", 50 x 88.9)

(HR) Stavite 2 x 4 ravno Pressure Obradeni vremenski dokazni drveni klin.
(Stvarnoj veličini 2"x 3 1/2", 50 x 88.9)

(HU) 2 x 4 sima nyomás kezelt időjárás bizonyítékot szegekkel fa
(Tényleges méret 2"x 3 1/2", 50 x 88.9)

(SV) Lagg 2 x 4 platt Tryck behandlat väder bevis trä dubbar.
(Verklig storlek 2"x 3 1/2", 50mm x 88.9mm)

(IT) Laici 2 x 4 pressione trattati Meteo prova.
(Dimensione attuale 2" x 3 1/2", 50 mm x 88.9 mm)

(PL) Połóż płasko słupki 2x4 Ciśnienia traktowane
pogodowodó drewna stadniny
(Rzeczywisty rozmiar 2"x 3 1/2", 50mm x 88.9mm)

(RO) Așezați plăcile 2 x 4 pe o suprafață plană
Pressure tratate de intemperii Wood Studs
(Dimensiunea reală 2" x 3 1/2", 50 x 88.9)

(BG) Поставете плоскост с размери 2 x 4 Pressure
Третирани Противотехнически дървесни щифтове.
(Застроена 2"x 3 1/2", 50 x 88.9)

(TR) 2 x 4 ölçüsünde zemin Pressure Tedavi Hava
geçirmez Ahşap Studs.
(2"x 3 1/2", 50 x 88.9 Gerçek boyut)

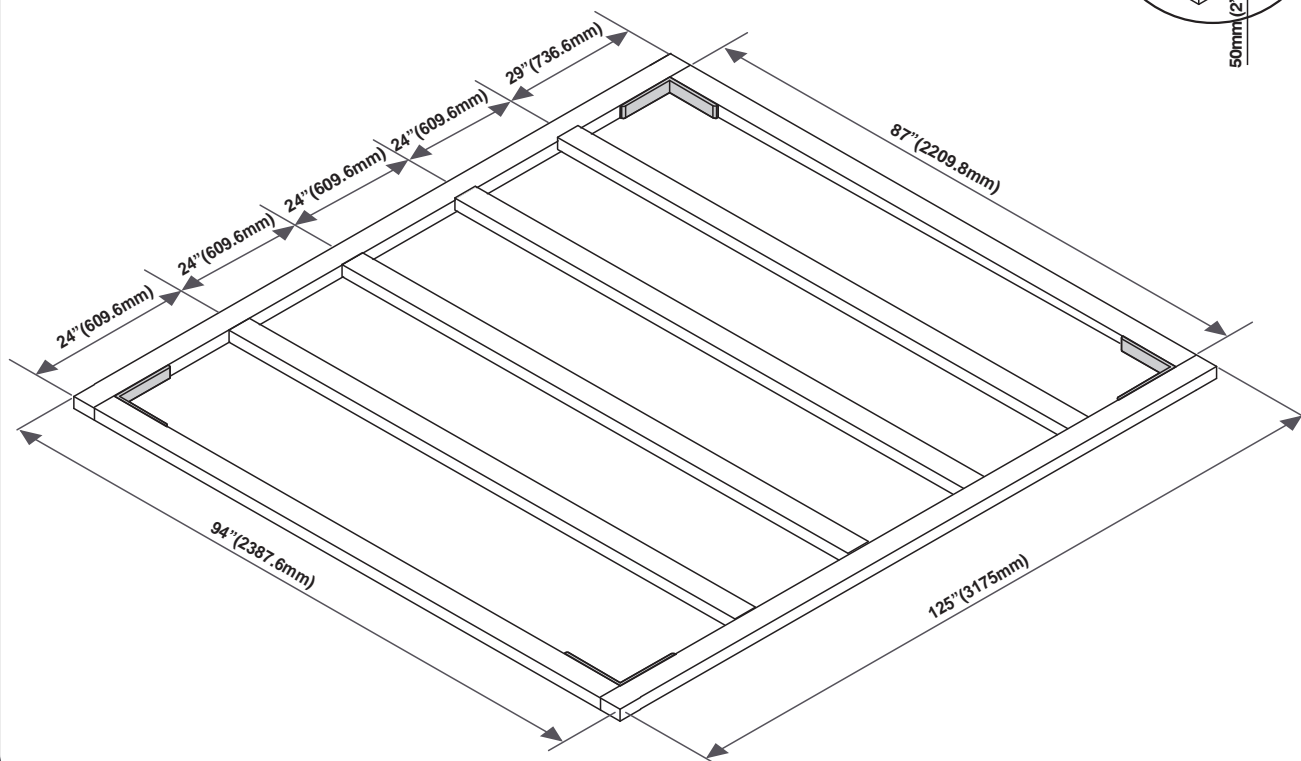
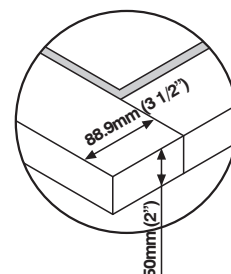

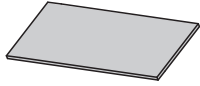

94"x 48" X 3/4" (x2)

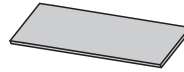

94"x 29" X 3/4" (x1)



(EN) Exterior Grade (CDX) - 3/4" (19mm) Weather proof Marine grade plywood

(FR) Qualité extérieure (CDX) - 3/4 po (19mm) météo preuve Marine grade contreplaqué..

(DE) Aussenansicht Grade (CDX) - 3/4" (19mm) Wetter Beweis Marine Grade Sperrholz.

(ES) Calidad para exteriores (CDX) - 3/4" (19mm) de madera contrachapada grado tiempo de prueba Marina.

(PT) Grade exterior (CDX) - 3/4" (19mm) tempo prova da classe madeira compensada marinha.

(NL) Exterieur Grade (CDX) - 3/4" (19mm) weer bewijs Marine grade multiplex.

(CS) vnější Grade (CDX) - 3/4" (19mm) počasí důkaz Marine překližované desky.

(SK) exteriéru Grade (CDX) - 3/4" (19mm) počasie dôkaz Marine preglejku.

(SL) zunanost razred (CDX) - 3/4" (19mm) vreme dokaz Marine Les

(HR) Exterior Grade (CDX) - 3/4" (19mm) Mjerno vrijeme morskara razreda šperploča..

(HU) külső fokozat (CDX) - 3/4" (19mm) Időjárás bizonyítékot tengeri minőségű rétegelt lemezt.

(SV) exteriör Grade (CDX) - 3/4" (19mm) väder bevis Marine grade plywood.

(IT) borchie di legno esterna Grade (CDX) - 3/4" (19mm) compensato Meteo prova Marine

(PL) Zewnętrzny stopień (CDX) - 3/4" (19mm) pogoda dowód Marine sklejkę :

(RO) Exterior Grad (CDX) - 3/4" (19mm) Rezistență la intemperii placaj de calitate marină.

(BG) Exterior Grade (CDX) - 3/4" (19mm) Противотемпературен шперплат.

(TR) Exterior Grade (CDX) - 3/4" (19mm) Hava geçirmez Deniz sınıfı kontrplak

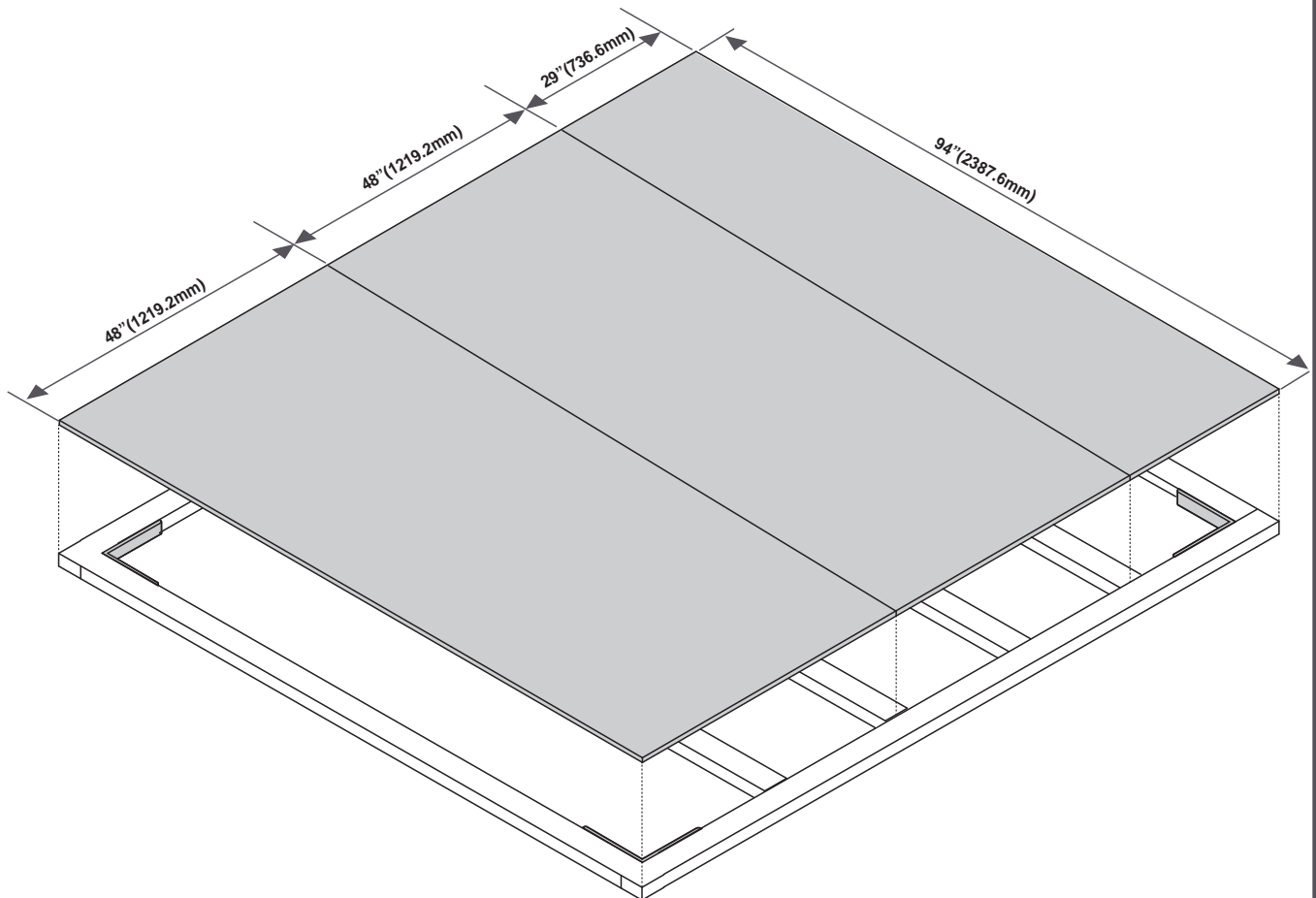

EN Concrete Platform

CS Betonové Platforma

IT Piattaforma in cemento

FR Plate-forme en béton armé

SK Betónové Platforma

PL Platforma betonowa

DE Betonauflage platform

SL Betonski Platform

RO Platforma de beton

ES Plataforma Concreta

HR Betonski Platform

BG Бетон Платформа

PT Plataforma concreta

HU Beton Platform

TR Beton Platform

NL Betonnen plaat

SV Betongplattform



EN To ensure that your shed withstands high winds, we recommended to use this floor option.

A concrete pad or a large size concrete patio stone squares is recommended for suitable floor base. Make sure it is firm and level and will allow drainage away from the site. Make a level concrete foundation, that has an outside dimension of 126 3/4" x 95 3/4" (3219mm x 2434mm). For a concrete pad base, prepare a level bed for a firm footing layer of crushed stone. The concrete pad should then be poured to a thickness of 4 inches (100mm) to 5 inches (125mm). Allow to dry thoroughly for at least 48 hours. Manufacturer is not responsible for the choice and construction of the foundation.

FR Pour vous assurer que votre hangar résiste à des vents violents, nous avons recommandé d'utiliser cette option de plancher.

Une dalle de béton ou une grande taille concrètes dalles de patio de est recommandé pour base appropriée au sol. Assurez-vous qu'il est ferme et niveau et permettre un bon drainage du site. Faire niveau fondation en béton, qui a une dimension extérieure de 126 3/4" x 95 3/4" (3219mm x 2434mm) Pour hanger de base.

Pour une dalle en béton, préparer une couche de graviers de nive au. La dalle doit faire entre 10 et 12.5 cm. Laissez sécher 1cm pour 10 jours. Le fabricant n'est pas responsable du choix et de la construction des fondations.

DE Um sicherzustellen, dass Ihr Schuppen hohen Winden standhält, empfiehlt es sich, diese Bodenoption zu benutzen.

Eine konkrete Auflage oder eine große Größe konkreten Patio Stein Quadrate wird empfohlen für die geeignete Standring. Stellen Sie sicher, es ist fest und Ebene und Entwässerung von der Website ermöglicht. Machen Sie eine Ebene Betonfundament, die eine externe Dimension von 126 3/4" x 95 3/4" (3219mm x 2434mm).

für eine konkrete Auflage hat base, einer soliden Basis Schicht aus Schotter ein Niveau Bett vorzubereiten. Die konkrete Auflage sollte dann zu einer Dicke von 4 Zoll (100 mm) bis 5 Zoll (125 mm) gegossen werden. Gründlich mindestens 48 Stunden trocknen lassen. Hersteller ist nicht verantwortlich für die Auswahl und Konstruktion der Stiftung.

ES Para asegurarse de que su cobertizo resiste vientos fuertes, se recomienda utilizar esta opción baja.

Un cojín concreto o los cuadrados concretos del tamaño grande de una piedra del patio se recomiendan para la base conveniente para el suelo. Asegúrese de que sea firme y llana y que permita drenaje lejos del sitio. Hacer una fundación nivel concreto que tiene una dimensión fuera de 126 3/4" x 95 3/4" (3219mm x 2434mm) cobertizo para Básico.

Para una base concreta del cojín, prepare una cama llana para una capa de pie firme de la piedra machacada. El cojín concreto se debe entonces verter a un grueso de 4 pulgadas (100mm) a 5 pulgadas (125mm). Permita secarse a fondo por lo menos 48 horas. El fabricante no es responsable de la opción y de la construcción de la fundación.

PT Para garantir que o seu galpão resiste a ventos fortes, recomendamos usar esta opção de andar.

Um bloco de concreto ou um quadrados de pedra de pátio de concreto de tamanho grande é recomendado para base apropriado do assoalho. Certifique-se que é firme e nivelada e permitirá drenagem longe do local. Fazer base de uma fundação de concreto nivel, que tem uma dimensão exterior de 126 3/4" x 95 3/4" (3219mm x 2434mm)

Em um bloco de concreto, preparar uma cama de nível para uma camada firme de brita. O base de concreto deve ser derramado em seguida a uma espessura de 4 polegadas (100mm), 5 polegadas (125mm). Deixe para secar completamente pelo menos 48 horas. Fabricante não é responsável pela escolha e construção da Fundação.

NL Om ervoor te zorgen dat uw schuur bestand is tegen hoge winden, raden wij u aan deze vloeroptie te gebruiken.

Een concrete pad of een groot formaat concrete patio stenen pleinen wordt aanbevolen voor geschikt woord basis. Zorg ervoor dat het is stevig en niveau en drainage zal bestaan weg van de site. Een niveau concrete stichting, die een externe dimensie van 126 3/4" x 95 3/4" (3219mm x 2434mm)

For a concrete pad base, prepare a level bed for a firm footing layer of crushed stone. The concrete pad should then be poured to a thickness of 4 inches (100mm) to 5 inches (125mm). Allow to dry thoroughly for at least 48 hours. Manufacturer is not responsible for the choice and construction of the foundation.

CS Abyste zajistili, že váš haly odolává silnému větru, doporučujeme použít tuto podlahu.

Pro vhodnou podlahovou základnu se doporučuje betonová podložka nebo velké betonové terasové čtverce. Ujistěte se, že je pevný a rovný a umožní odvodnění od místa. Vytvořte hladký betonový podklad, který má vnější rozměr 126 3/4" x 95 3/4" (3219mm x 2434mm) pro základní shed.

U betonové podložky připravte rovnou lůžko pro pevnou podkladovou vrstvu drčeného kamene. Betonová vložka by měla být nalita do tloušťky od 100 palců do 5 palců (125 milimetrů). Nechte důkladně vyschnout po dobu nejméně 48 hodin. Výrobce nezodpovídá za volbu a výstavbu nadace.

SK Aby ste zabezpečili, že vaša haly odolá vysokému vetru, odporúčame použiť túto podlahovú možnosť.

Na vhodnú podlahovú základňu sa odporúča betónová podložka alebo veľké betónové terasové kamenné štvorce. Uistite sa, že je pevný a rovný a umožní odvodnenie z miesta. Vytvorte základový betónový základ, ktorý má vonkajší rozmer 126 3/4" x 95 3/4" (3219mm x 2434mm) pre základňu.

Pre betónové podložky pripravte rovnú vrstvu pre pevnú základovú vrstvu drveného kameňa. Betónová podložka by mala byť potom naliatá do hrúbky 4 palce (100 mm) až 5 palcov (125 mm). Nechajte dôkladne vysušiť aspoň 48 hodín. Výrobca nie je zodpovedný za výber a výstavbu nadácie.

SL Da bi zagotovili, da bo vaša hiša odtegnila visoke vetrove, smo priporočili, da uporabite to možnost.

Za primerne talne podlage je priporočljiva betonska podloga ali betonski trgi z velikimi površinami. Priprčajte se, da je čvrsta in raven ter omogočila drenažo stran od mesta. Izdelajte ravno betonsko podlago, ki ima zunanjo dimenzijo dimenzij 126 3/4" x 95 3/4" (3219mm x 2434mm) za Basic Shed.

Za betonsko podlago pripravite ravno posteljo za trdno podlago iz drobljenega kamna. Betonsko ploščo je treba nato vliti do debeline 4 palcev (100 mm) do 5 palcev (125 mm). Pustite, da se temeljito posuši najmanj 48 ur. Proizvajalec ni odgovoren za izbiro in gradnjo temeljev.

HR Da bismo osigurali da vaš prolaz izdrži jak vjetar, preporučujemo da upotrijebite tu podu.

Za pogodnu podnu bazu preporučuje se betonska podloga ili velike kamene ploče od betona. Pobrinite se da je čvrsta i razina i omogućit će odvod daleko od stranice. Izradite temeljni betonski temelj koji ima vanjsku dimenziju od 126 3/4" x 95 3/4" (3219mm x 2434mm) za Basic Shed.

Za betonsku podlogu, pripremite krevet na razini za čvrsto podnožje slomljenog kamena. Betonsku podlogu treba zatim izliti na debljinu od 100 mm do 125 inča. Ostavite temeljito suhom najmanje 48 sati. Proizvođač nije odgovoran za odabir i izgradnju zaklade.



HU Annak érdekében, hogy a fészker ellenálljon a magas szeleknek, javasoljuk, hogy használja ezt a padlót. Betonpárna vagy nagyméretű betonpadló kőpadok ajánlottak megfelelő padlóalakra. Győződjön meg arról, hogy szilárd és vízszintes, és lehetővé teszi a vízvezetést távol a helyszíntől. Végezzünk el egy szintetikus alapot, amely 126 3/4" x 95 3/4" (3219mm x 2434mm) külső méretekkel rendelkezik a Basic Shed számára. Betonpárnás aljzat esetén készítsen egy szintes ágyat egy szilárd alapozórétegre. A betonpárnát ezután 100 mm-es és 125 mm-es vastagságúra kell önteni. Legalább 48 órán keresztül hagyja alaposan száradni. A gyártó nem vállal felelősséget az alapítvány kiválasztásához és megépítéséért.

SV För att säkerställa att din skjul tål hög vind rekommenderar vi att du använder det här golvalternativet. En betongkudde eller en stor betongplattform stenplattor rekommenderas för lämplig golvyta. Se till att den är fast och jämn och gör det möjligt att dränera bort från platsen. Gör en jämn betongfundament, som har en yttre dimension av 126 3/4" x 95 3/4" (3219mm x 2434mm) för Basic Shed. För en betongplatta bas, förbereda en nivå säng för ett fast fotskikt av krossad sten. Betongplattan ska sedan hällas till en tjocklek av 4 tum (100 mm) till 5 tum (125 mm). Låt torka noggrant i minst 48 timmar. Tillverkaren ansvarar inte för valet och bygandet av stiftelsen.

IT Per garantire che il tuo capannone sopporta venti elevati, abbiamo consigliato di utilizzare questa opzione a pavimento. Si consiglia un tappetino in calcestruzzo o un quadrato in pietra di cemento in grande formato per una base adatta. Assicurarsi che sia stabile e livellato e permetterebbe di drenare lontano dal sito. Realizzare una base di calcestruzzo di livello, che ha una dimensione esterna di 126 3/4" x 95 3/4" (3219mm x 2434mm) per Basic Shed. Per una base di rilievo in calcestruzzo, preparare un letto a livello per un solido strato di pietra schiacciata. Il tappetino di calcestruzzo deve quindi essere versato ad uno spessore da 100 mm a 125 centimetri. Lasciare asciugare accuratamente per almeno 48 ore. Il produttore non è responsabile della scelta e della costruzione della fondazione.

PL W celu zapewnienia, że szopy wytrzymują wysokie wiatry, zalecamy skorzystanie z tej opcji podłogi. Betonu pad lub duży rozmiar konkretne patio kamień kwadratów jest zalecane dla odpowiedniej bazy piętro. Upewnij się, że to jest prosto i stabilnie i pozwoli drenaż witrny. Zrobić fundamentie betonowym poziom, który ma wymiar zewnętrzny 126 3/4" x 95 3/4" (3219mm x 2434mm). Do betonu pad podstawy, przygotować łóżko poziom dla firmy stopie warstwę tłucznia. Betonu pad powinien być następnie przelewa się do grubości 4 cali (100mm) do 5 cali (125mm). Pozostawić do wyschnięcia dokładnie na co najmniej 48 godzin. Producent nie jest odpowiedzialny za wybór i budowie fundamentów.

RO Pentru a vă asigura că vaporul dvs. rezistă unor vânturi puternice, am recomandat să folosiți această opțiune pentru podea. Un tampon de beton sau o pătrată de piatră din beton de dimensiuni mari este recomandată pentru o bază adecvată pentru podea. Asigurați-vă că este ferm și la nivel și va permite scurgerea departe de site. Asigurați o fundație de beton de nivel, care are o dimensiune exterioră de 126 3/4" x 95 3/4" (3219mm x 2434mm) pentru Shed Basic. Pentru o bază de bază de beton, pregătiți un pat de nivel pentru un strat ferm de piatră zdrobită. Plăcuța de beton trebuie apoi turnată la o grosime de 4 inci (100 mm) până la 5 inci (125 mm). Lăsați-l să se usuce bine timp de cel puțin 48 de ore. Producătorul nu este responsabil pentru alegerea și construirea fundației.

BG За да сте сигурни, че Вашата барака издържа високи ветрове, препоръчваме да използвате тази опция за пода. За подходяща подова основа се препоръчва използването на бетонна подложка или големи бетонни квадратни плочки. Уверете се, че тя е здрава и равна и ще позволи дренаж далеч от мястото. Направете нивелирана бетонна основа, която има външен размер от 126 3/4" x 95 3/4" (3219mm x 2434mm) за основен навес. За бетон основа на подложка, подгответе ниво легло за твърда основа слой от натрошен камък. След това бетонната подложка трябва да се излива на дебелина от 4 инча (100 mm) до 5 инча (125 mm). Оставете да изсъхне напълно за поне 48 часа. Производителят не носи отговорност за избора и изграждането на основата.

TR Sunduğunuzdan yüksek rüzgarlara dayanıklı olmasını sağlamak için bu zemin seçeneğini kullanmanızı öneririz. Uygun taban tabanı için beton bir yastık veya büyük boy bir beton bahçe avlusu karosu önerilir. Sert ve sağlam olduğundan ve drenajın yerinden uzaklaşmasına izin vereceğinden emin olun. Basic Shed için dış boyut 126 3/4" x 95 3/4" (3219mm x 2434mm) olan düz bir beton temel oluşturun. Beton pad taban için, ezilmiş taştan sağlam bir taban tabakası için düz bir yatak hazırlayın. Beton pedi daha sonra 4 inç (100mm) ile 5 inç (125mm) arasındaki bir kalınlığa dökülmelidir. En az 48 saat boyunca iyice kurummasına izin verin. Üretici, vakfın seçimi ve yapımı için sorumlu değildir.

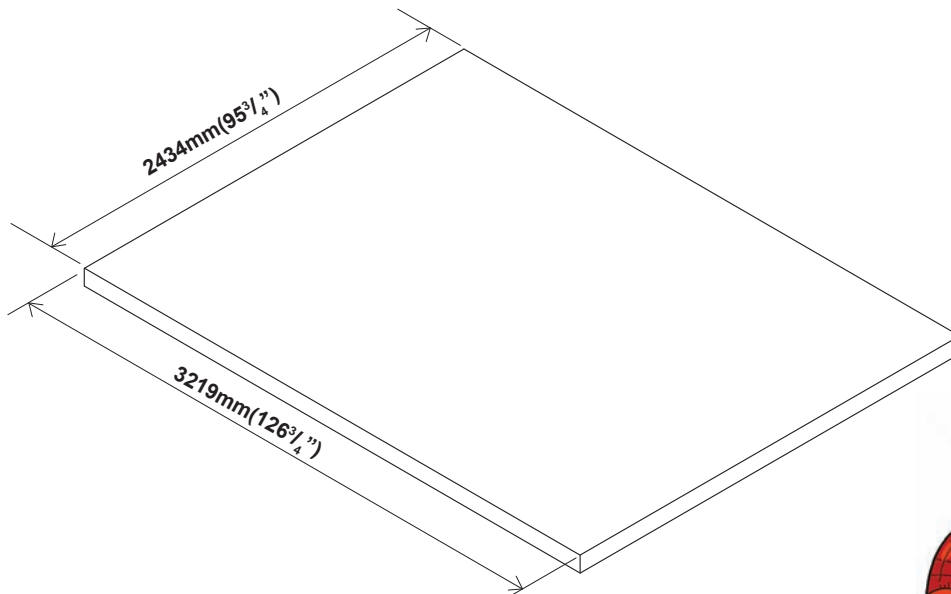



1	EN	Base Frame	CS	Základní kostra	IT	Cornice di Base
	FR	Canaux de base	SK	Základňový rám	PL	Rama fundamentowa
	DE	Bodenrahmen	SL	Osnovni okvir	RO	Rama bazei
	ES	Armazón de la base	HR	Baza okvir	BG	Основа Рама
	PT	Base de armação	HU	Alapváz	TR	Temel Çerçevesi
	NL	Basis frame	SV	Basram		

- EN** 1. Set the Torque limit of your Screw drill to #3 or #4 to ensure the Screws do not strip the Metal reinforcements.
2. It is important that these instructions are followed step by step.
3. Don't install under windy conditions.
- FR** 1. Réglez la limite de couple de votre perceuse Vis à n # 3 ou n # 4 pour s'assurer que les vis ne supprime pas les renforts métalliques
2. Il est important que ces instructions soient suivies pas à pas.
3. Ne pas installer sous conditions de vent.
- DE** 1. Stellen Sie die Torque Limit Ihres Schraube Bohrer # 3 oder # 4, um die Schrauben sicher nicht strip den Metallverstärkungen.
2. Diese Anleitung muss unbedingt Schritt für Schritt befolgt werden.
3. Die Montage nicht bei windigem Wetter vornehmen.
- ES** 1. Establecer el límite de par de su taladro tornillo de # 3 y # 4 para asegurar los tornillos no tira los refuerzos metálicos.
2. es importante que estas instrucciones se sigan paso a paso.
3. No instale las condiciones abajo de mucho viento.
- PT** 1. Defina o limite de Torque de sua broca parafuso para # 3 ou # 4 para garantir que os parafusos não tira os reforços de metal.
2. É importante que estas instruções sejam seguidas passo a passo.
3. Não instale sob condições com forças ventanosas.
- NL** 1. Stel de Torque limiet van uw Schroef boormachine op # 3 en # 4 om de schroeven zorgen niet strip de Metal versterkingen.
2. Het is belangrijk dat volgende instructies stap voor stap worden gerespecteerd.
3. Nooit de schuur installeren onder winderige omstandigheden.
- CS** 1. Nastavte mezní hodnotu točivého momentu vrtacího vrtáku na #3 nebo #4, abyste zajistili, že šrouby neztáhnou kovové výztuhy.
2. Je důležité aby jste tento návod sledovali krok za krokem.
3. Nemontujte při větrném počasí.
- SK** 1. Nastavte limit krútiaceho momentu vrtacieho vrtáka na #3 alebo #4, aby ste zaistili, že skrutky nezaberajú kovové výstuhy.
2. Je nutné dodržiavať tieto inštrukcie krok za krokom.
3. Neinštalujte za veterných podmienok.
- SL** 1. Za omejitev vrtilnega momenta vijalnega vijaka nastavite #3 ali #4, da zagotovite, da vijaki ne ojačitijo kovinskih ojačitev.
2. Pomembno je, da sledite opisanim navodilom korak za korakom.
3. Montaže ne izvijajte, kadar piha močen veter.
- HR** 1. Postavite granicu zakretnog momenta Vašeg vijčanog bušilica na #3 ili #4 kako biste osigurali da vijci ne skidaju metalna pojačanja.
2. To je važno da ovih instrukcije su slijedili korak po korak.
3. Nemojte instalirati pod vjetrovitim uvjetima.
- HU** 1. Állítsa a csavarhúzó nyomatékhatárait #3 vagy #4-re, hogy a csavarok ne csavarják le a fém vasalatokat
2. Fontos, hogy az itt következő instrukciókat lépésről lépésre betartsa.
3. Szeles időben ne végezzen összeszerelést.
- SV** 1. Ställ in momentskraven på din skruvborr till #3 eller #4 för att säkerställa att skruvarna inte slår av metallförstärkningarna.
2. Det är viktigt att dessa instruktioner följs steg för steg.
3. Installera inte när det är blåsigt.
- IT** 1. Impostare il limite di coppia della fresa a vite a #3 o #4 per assicurare che le viti non striscia i rinforzi metallici
2. E' molto importante che queste istruzioni vengano seguite passo dopo passo.
3. Non installare in presenza di forte vento.
- PL** 1. Zestaw limit momentu obrotowego twój śruby wiercenia do # 3 lub # 4, aby upewnić się, że śruby nie taśmy wzmocnień
2. Bardzo ważne jest, by dokładnie stosować się do niniejszej instrukcji.
3. Nie należy montować w przypadku silnego wiatru.
- RO** 1. Setati limita de cuplu a burghiului dvs. de şurub la #3 sau #4 pentru a vă asigura că şuruburile nu lărgeşte armăturile metalice.
2. Este importantă respectarea pas cu pas a acestor instrucțiuni.
3. Nu instalați dacă vântul atinge viteze mari.
- BG** 1. Нагласете границата на въртящия момент на винтовата витла до #3 или #4, за да се уверите, че винтовете не изрязват металните подсилвания.
2. Важно е да следвате инструкциите стъпка по стъпка.
3. Да не се монтира при ветровито време.
- TR** 1. Vidaların Metal takviyeleri soymadığından emin olmak için Vidalı matkabınızın Moment sınırını #3 veya #4'e ayarlayın.
2. Talimatların sırasıyla uygulanması önemlidir.
3. Rüzgarlı havalarda kurmayınız.



EN Parts needed

FR Pièces nécessaires

DE Benötigte Teile

ES Las partes necesarias

PT Peças Necessárias

NL Onderdelen nodig

CS Potřebné součásti

SK Potrebné časti

SL Dele, ki jih boste potrebovali

HR Dijelovi potreban

HU Szükséges részek

SV Delar som behövs

IT Parti occorrenti

PL Niezbędne elementy

RO Elementele componente necesare

BG Необходими части

TR Gerekli parçalar

MA01	1
MA02	1
MA03	2
MA04	2
MA05	2
MA06	1
MA07	4
S1	32



1

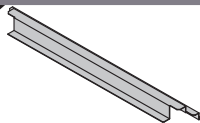

MA01 (x1)
MA02 (x1)



S1 (x4)

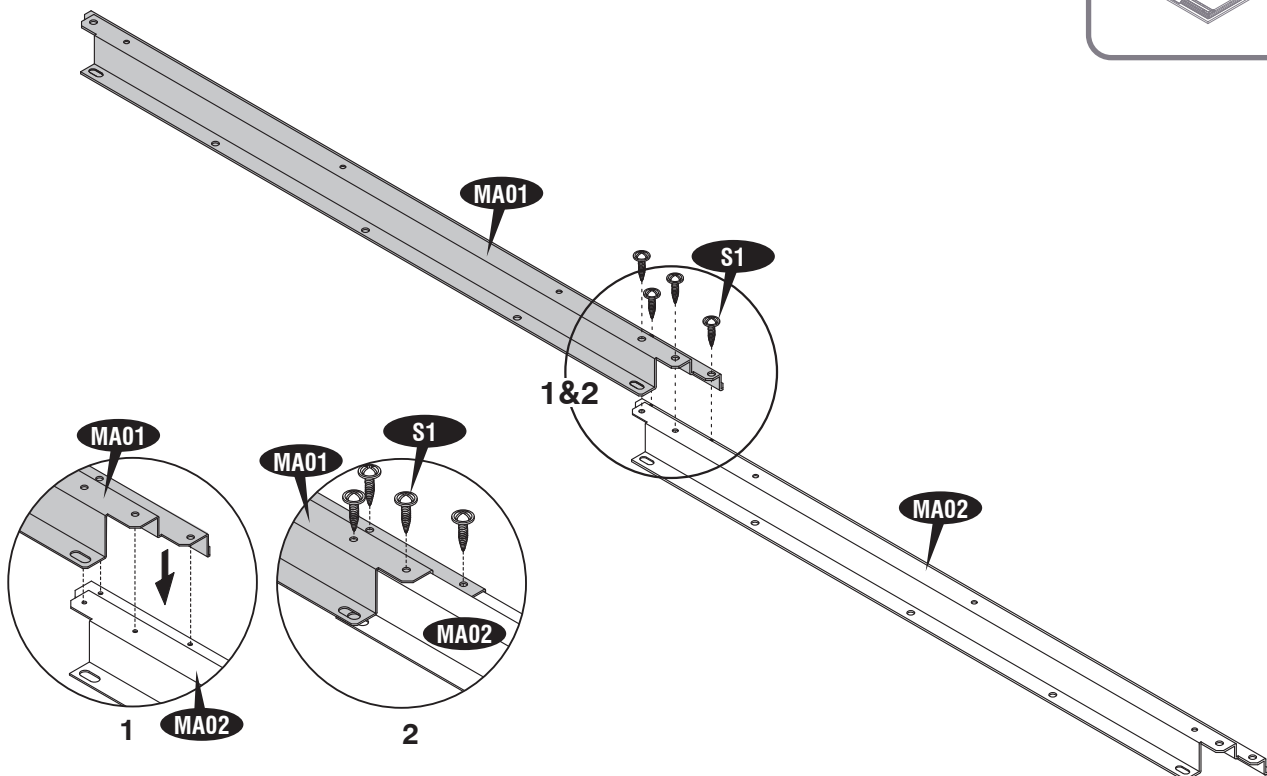
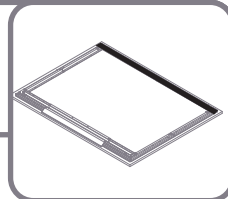

2

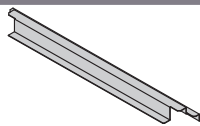

MA03 (x2)
MA04 (x2)



S1 (x8)



x2

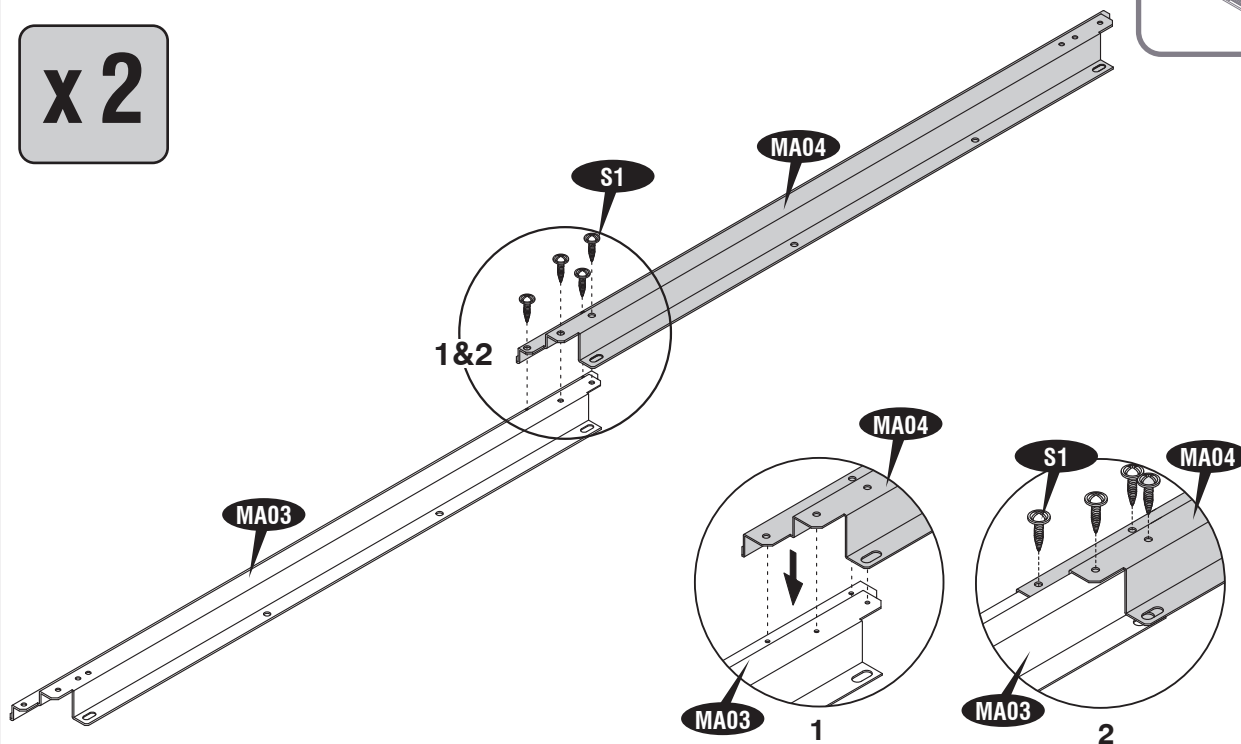

3

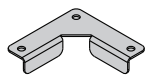

MA07 (x2)



S1 (x8)

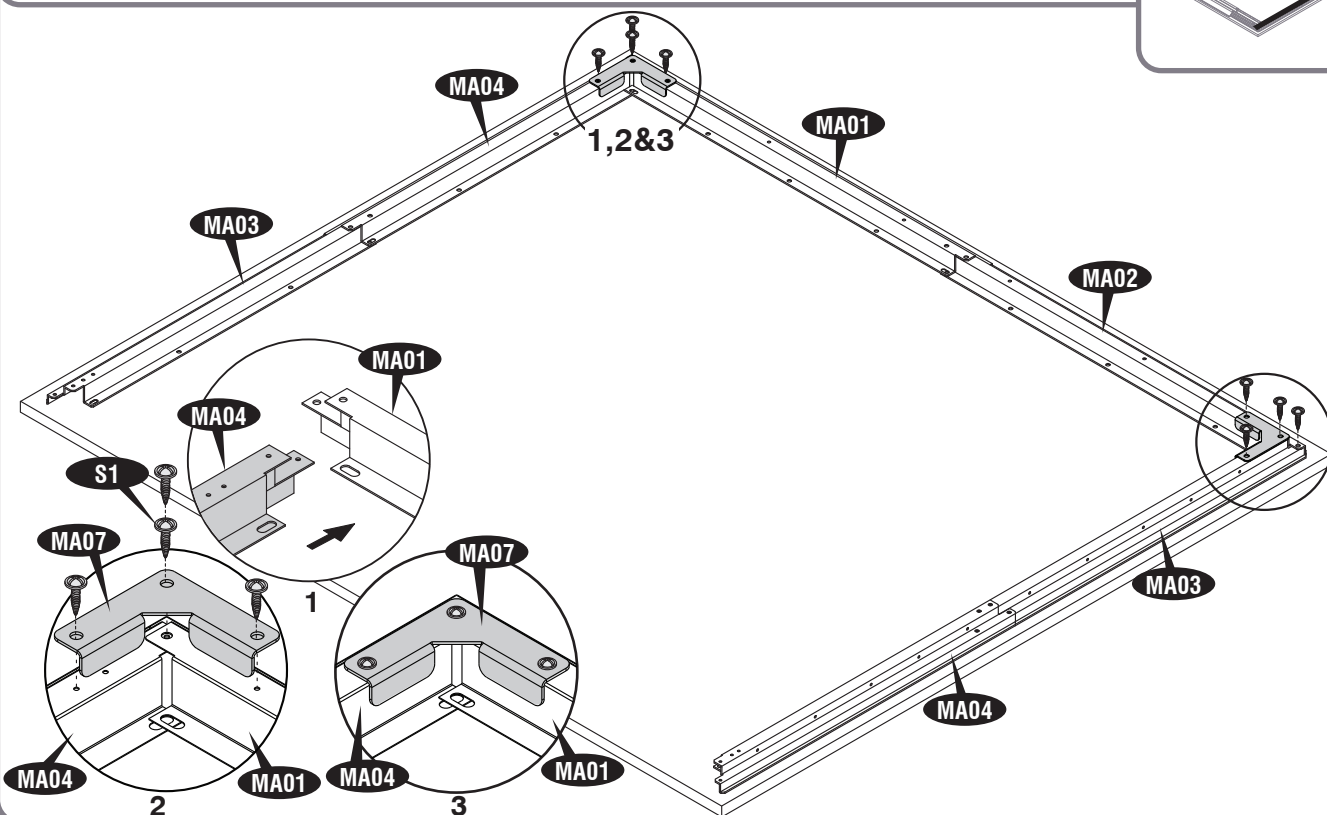

4

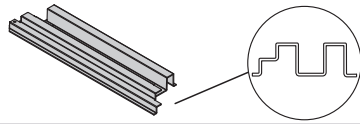

MA05 (x2)

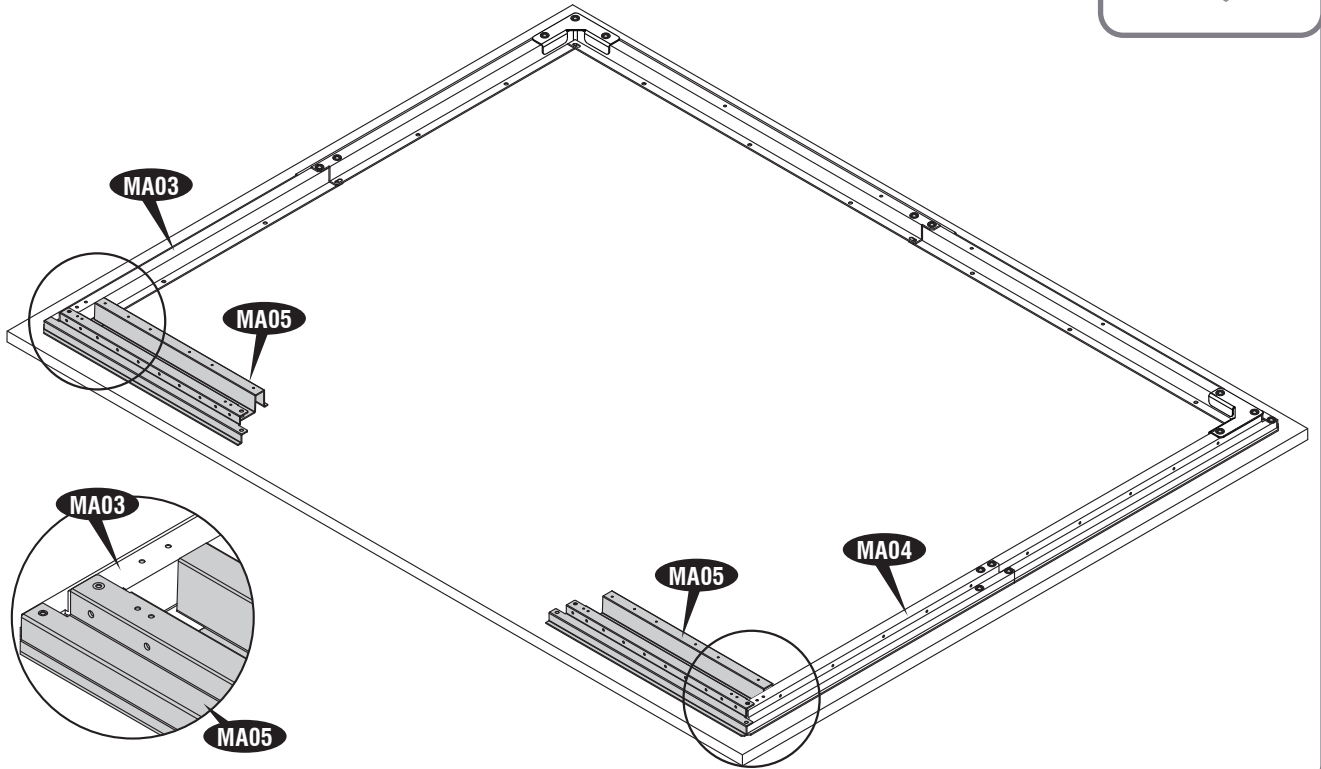
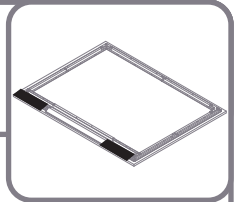

5

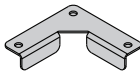

MA07 (x2)



S1 (x8)

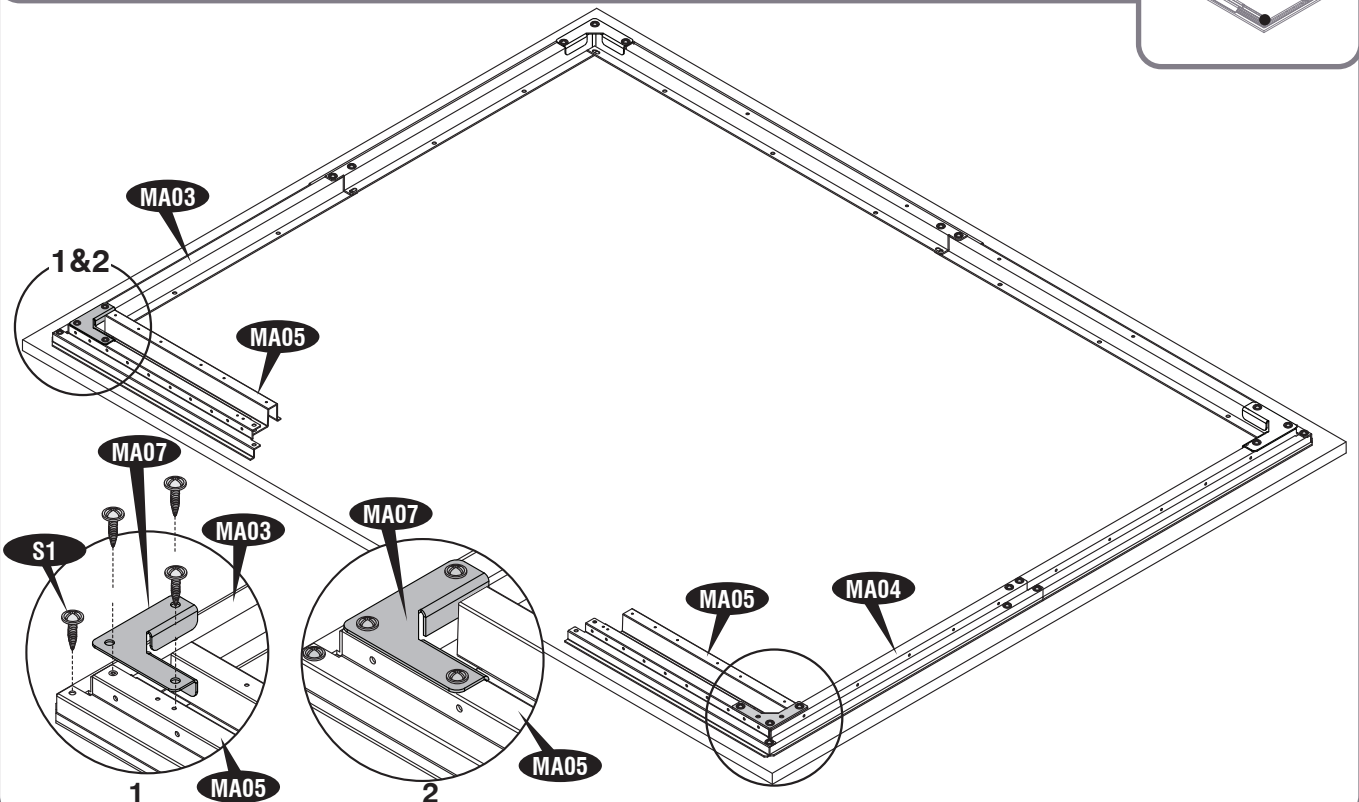
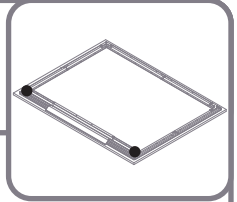

6

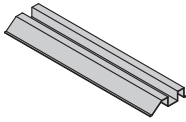

MA06 (x1)



S1 (x4)

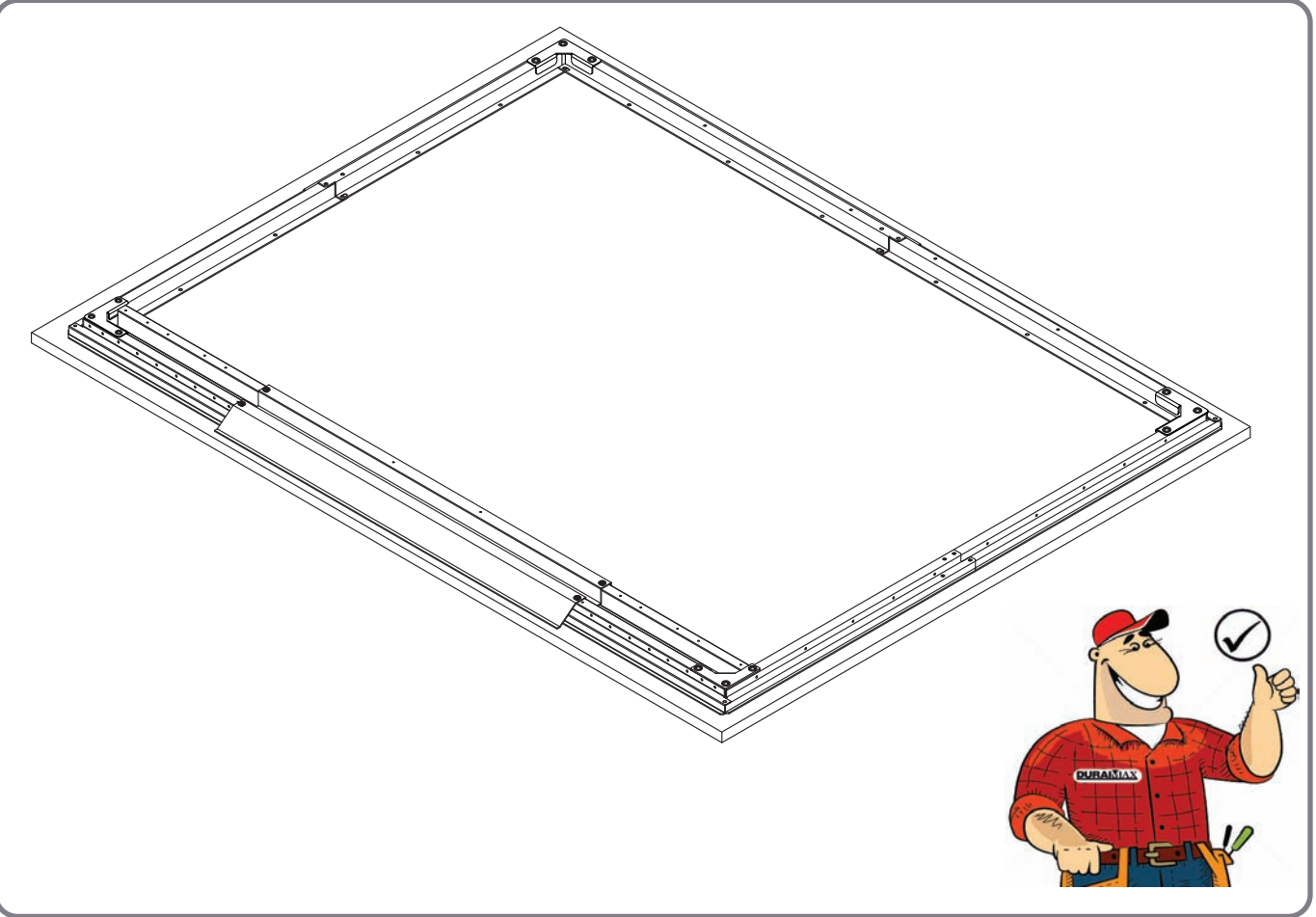
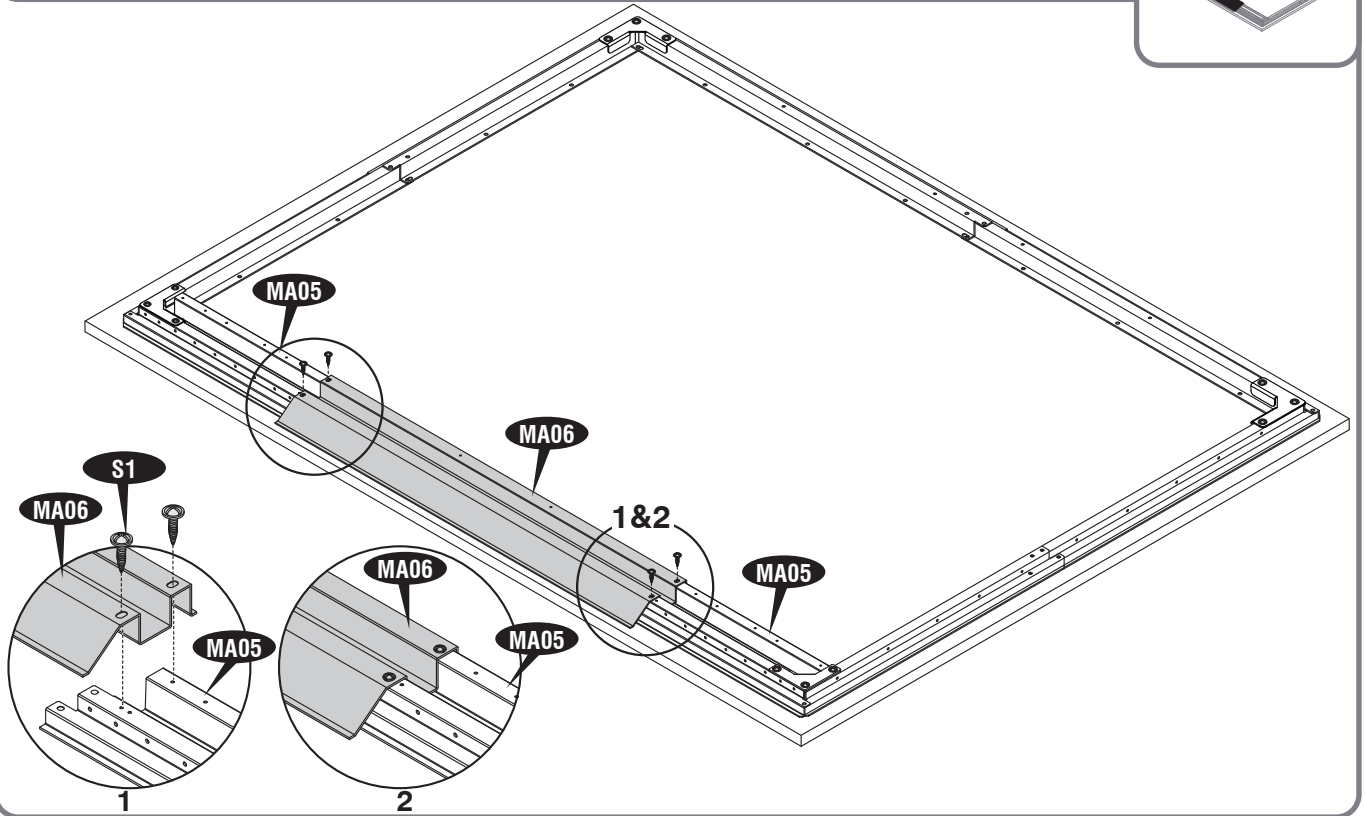
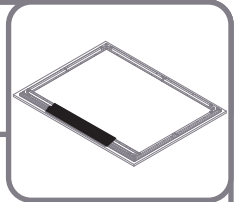



- 2**
- | | | |
|-------------------------|--------------------|----------------------|
| EN Walls & Columns | CS Základní kostra | IT Cornice di Base |
| FR Murs et colonnes | SK Základňový rám | PL Rama fundamentowa |
| DE Murs et colonnes | SL Osnovni okvir | RO Rama bazei |
| ES Las partes necesitan | HR Baza okvir | BG Основна Рама |
| PT Paredes e Colunas | HU Alapváz | TR Temel Çerçevesi |
| NL Basis frame | SV Basram | |

- | | | |
|-------------------------|-----------------------------------|-----------------------------------|
| EN Parts needed | CS Potřebné součásti | IT Parti occorrenti |
| FR Pièces nécessaires | SK Potřebné časti | PL Niezbędne elementy |
| DE Benötigte Teile | SL Dele, ki jih boste potrebovali | RO Elementele componente necesare |
| ES Las partes necesitan | HR Dijelovi potreban | BG Необходими части |
| PT Peças Necessárias | HU Szükséges részek | TR Gerekli parçalar |
| NL Onderdelen nodig | SV Delar som behövs | |

MA10	1	ME03	2	ME10	3	ME28	9
MA11	1	ME04	2	ME11	2	PW	146
MA12	1	ME05	2	ME12	1	S1	186
MA13	1	ME06	2	ME13	1	S3	4
MA14	1	ME07	2	ME14	1		
ME01	1	ME08	1	ME26	2		
ME02	1	ME09	1	ME27	4		

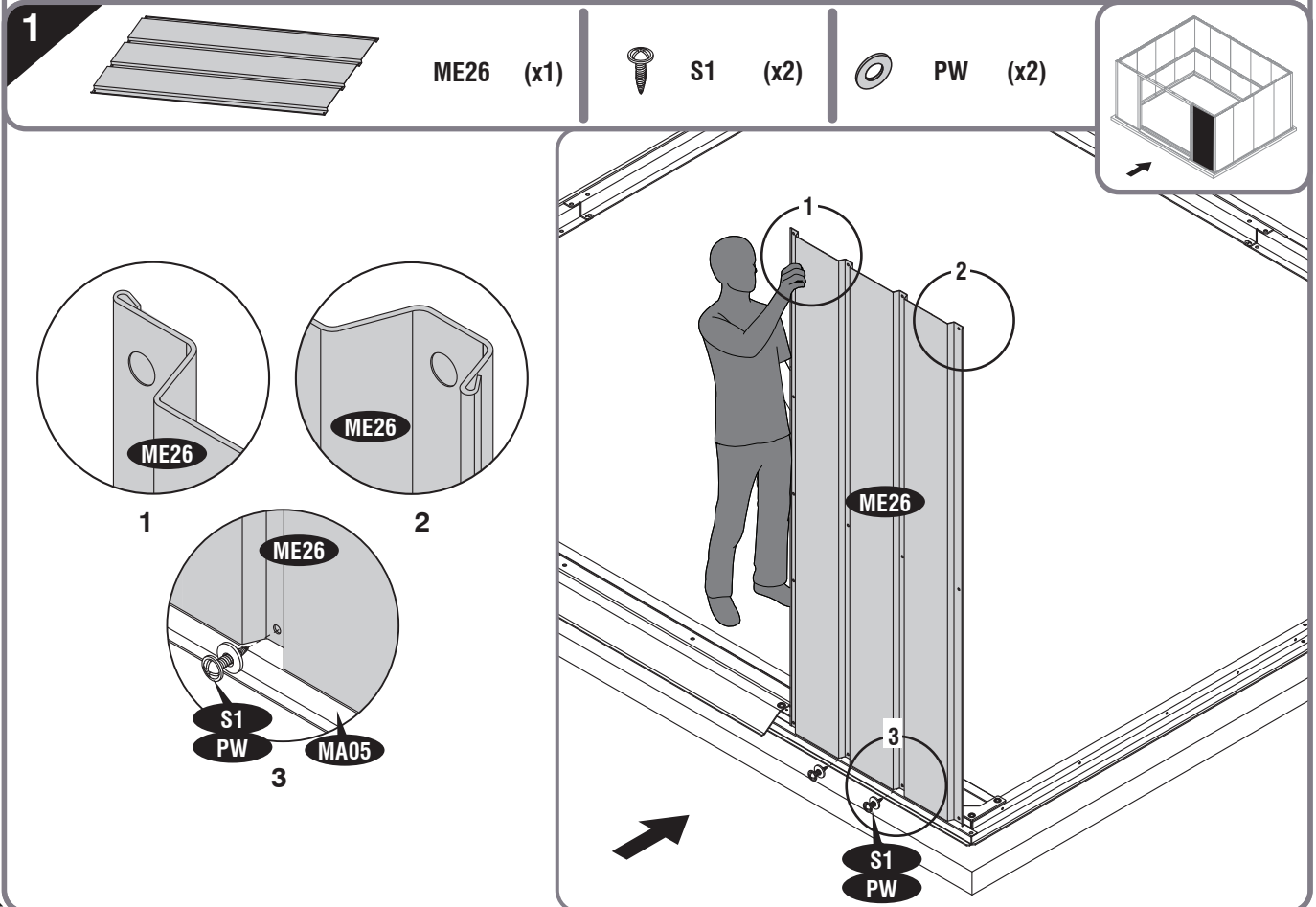

2

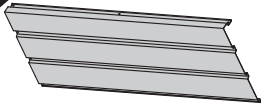

ME27 (x1)



S1 (x3)



PW (x3)

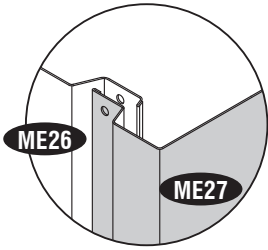
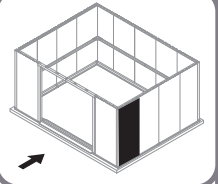

1

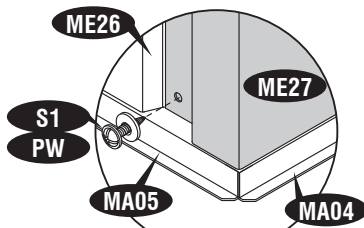

2

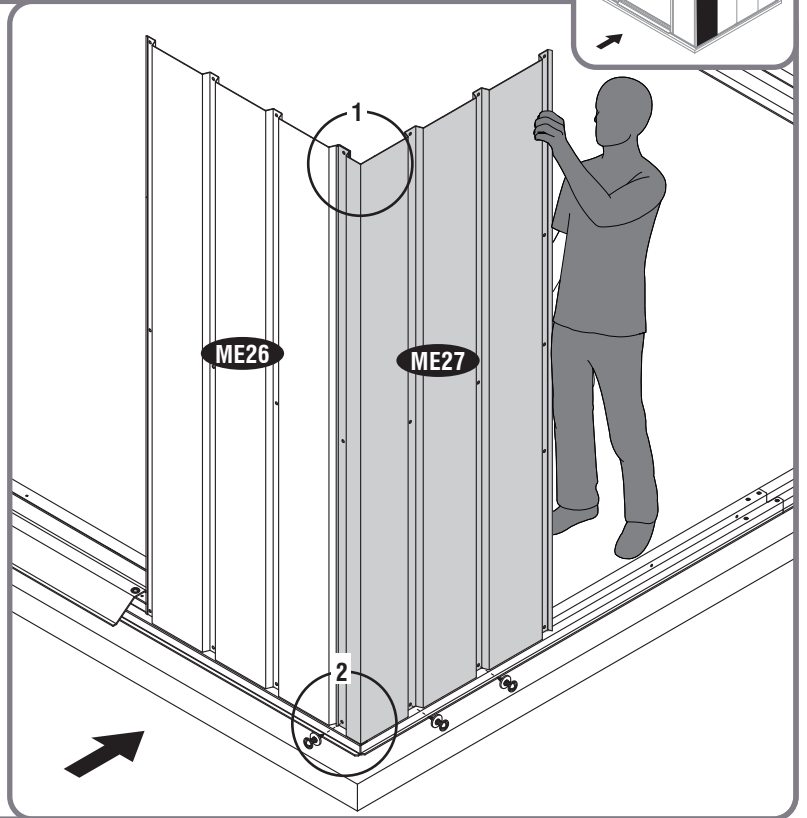

3

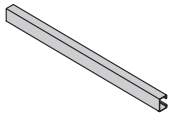

MA11 (x1)



S1 (x3)



PW (x3)

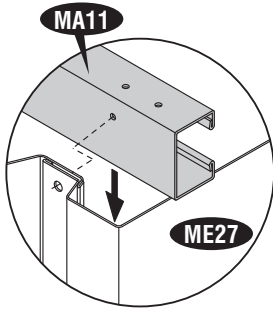
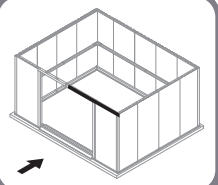

1

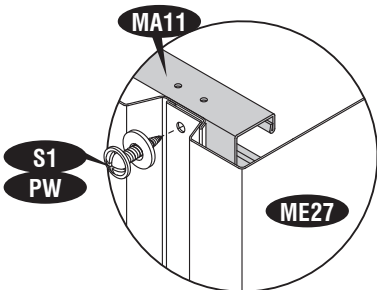

2

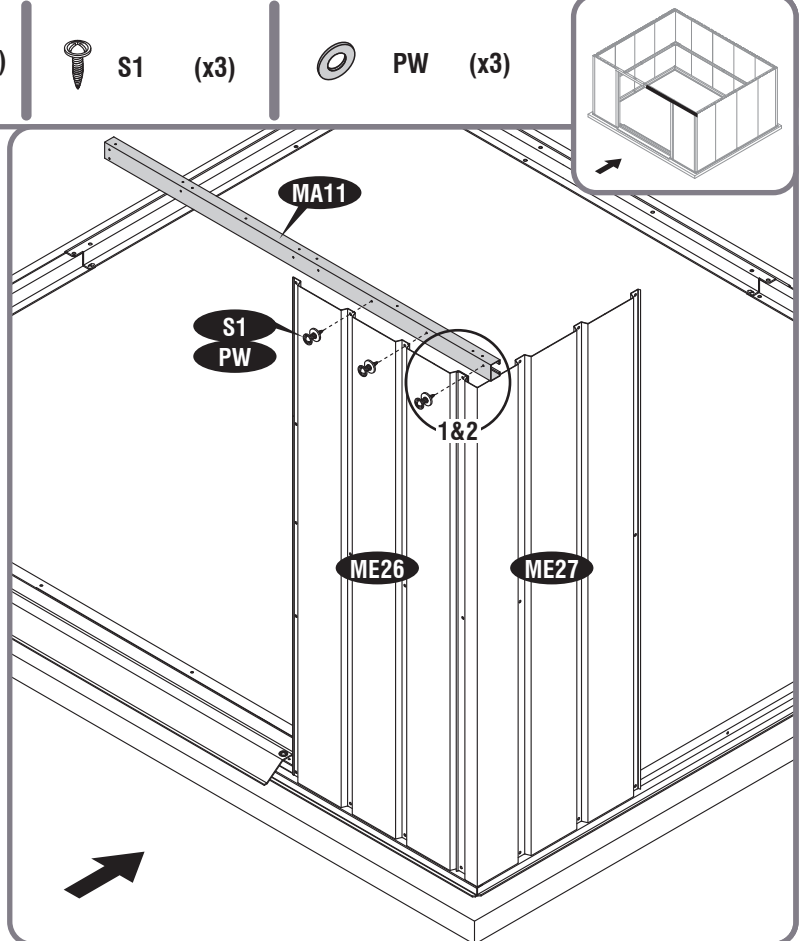

4

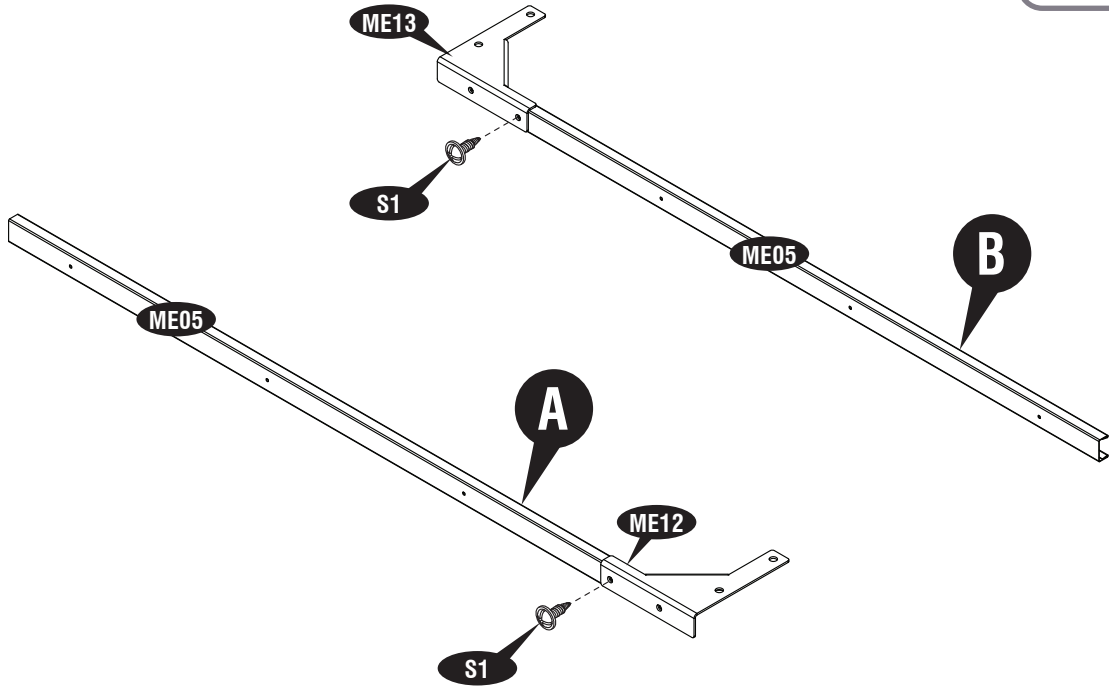
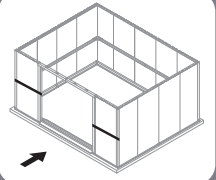
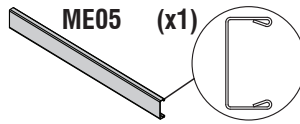

5

ME06 (x2)
ME07 (x2)

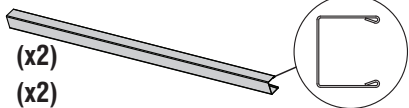

ME10 (x2)

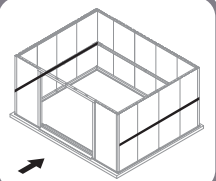
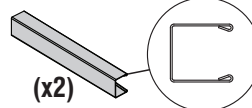

x2

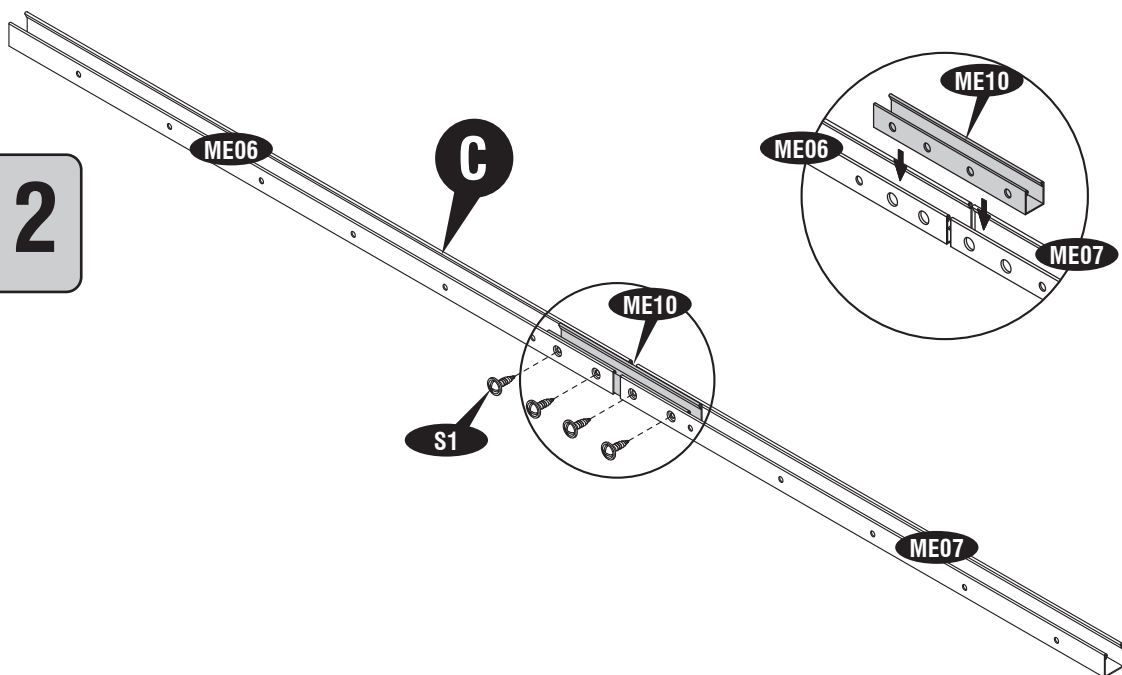

6

ME08 (x1)
ME09 (x1)

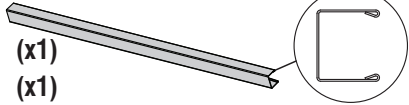

ME10 (x1)

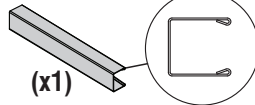

S1 (x4)

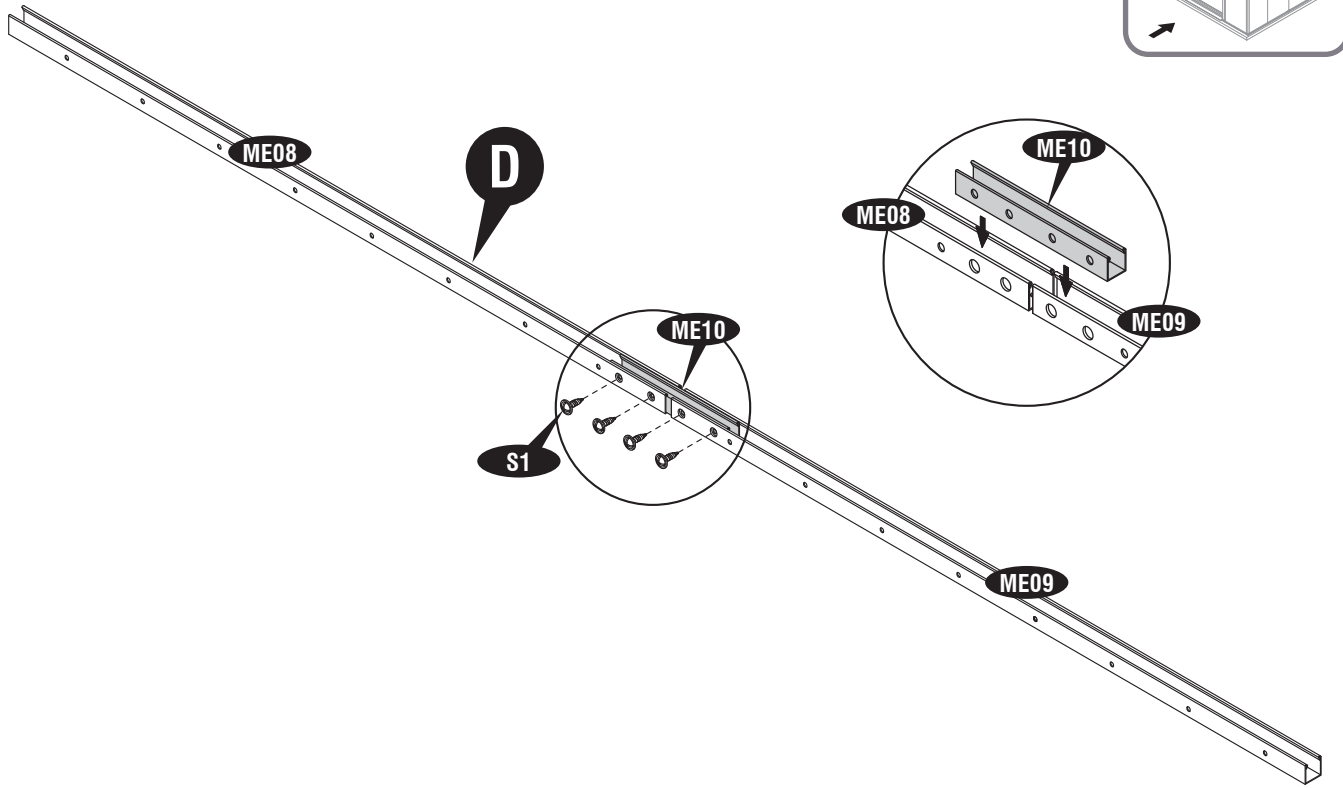
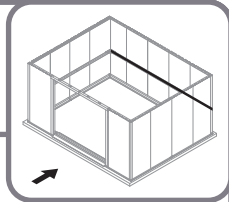

7

S1 (x3)

PW (x3)

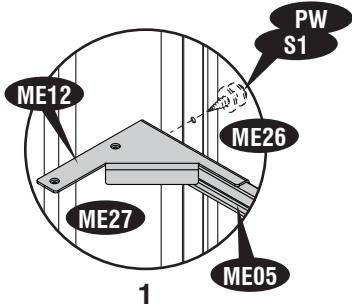
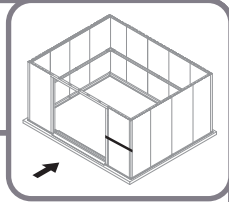

1

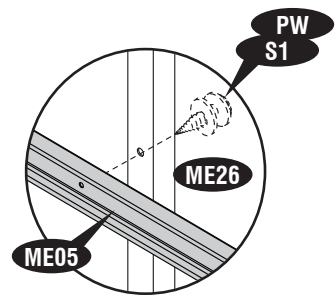

2

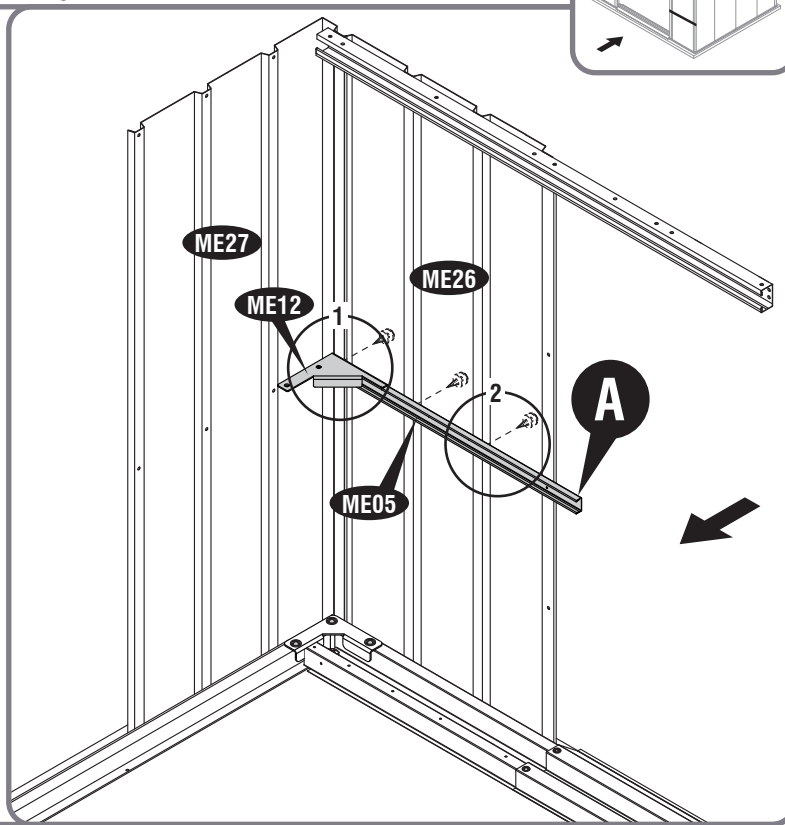

8

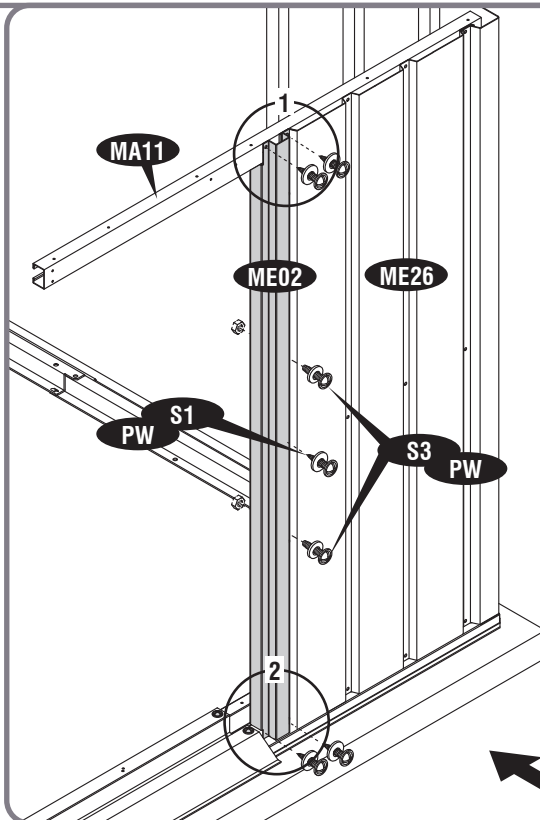
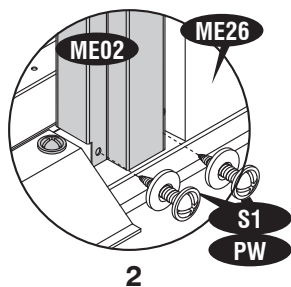
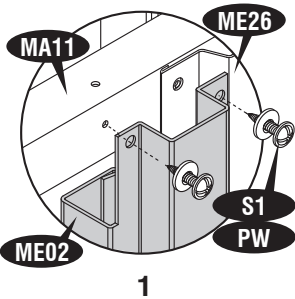
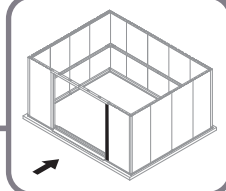
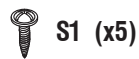
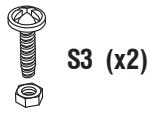
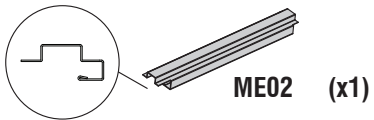

9

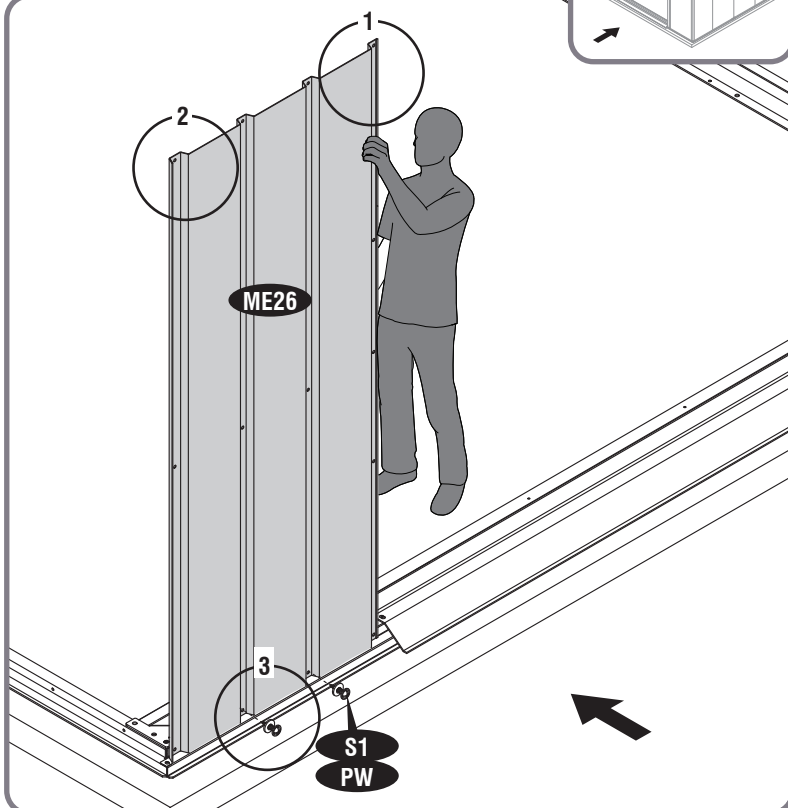
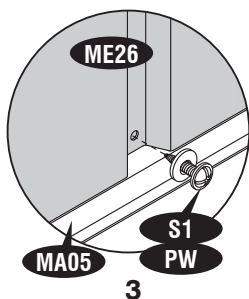
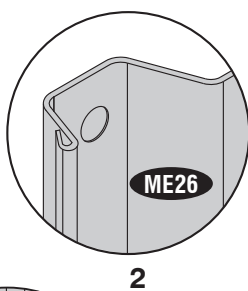
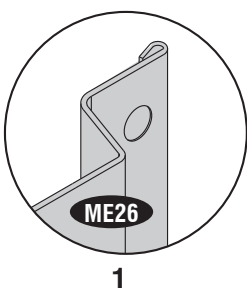
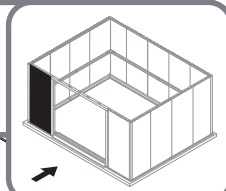
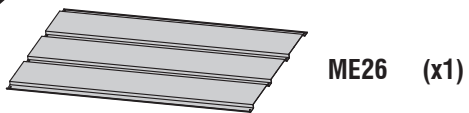

10

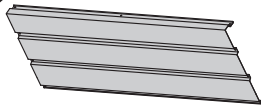

ME27 (x1)



S1 (x3)



PW (x3)

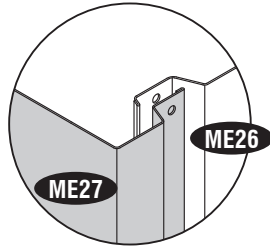
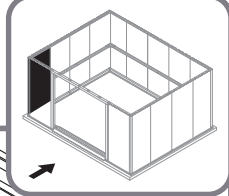

1

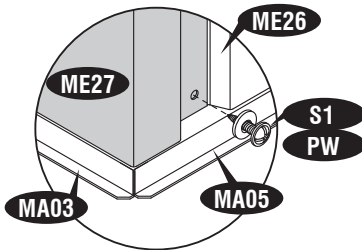

2

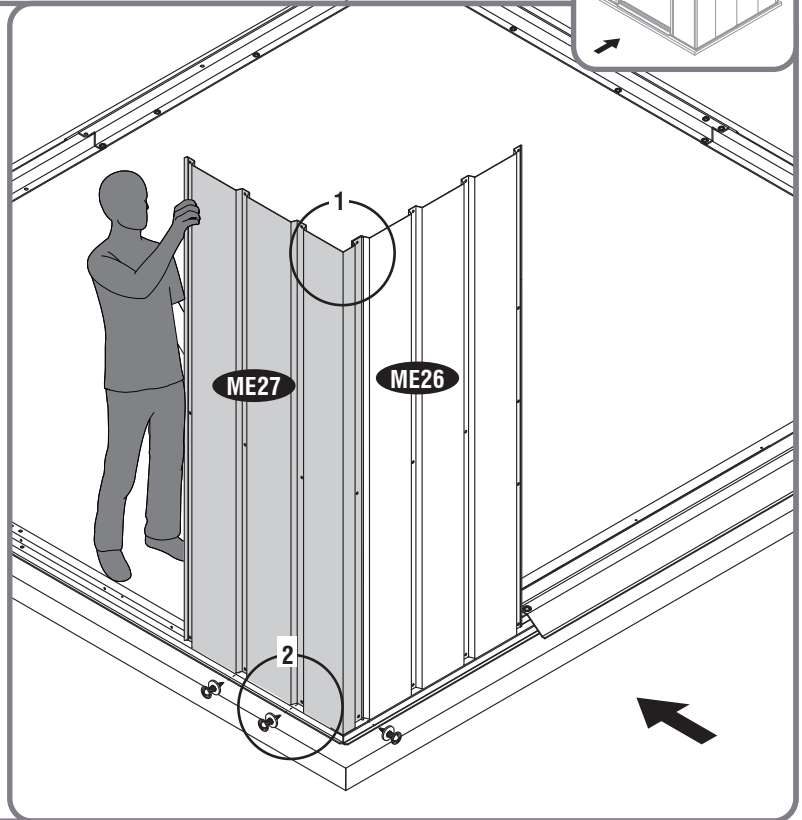

11

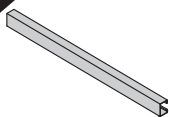

MA10 (x1)



S1 (x3)



PW (x3)

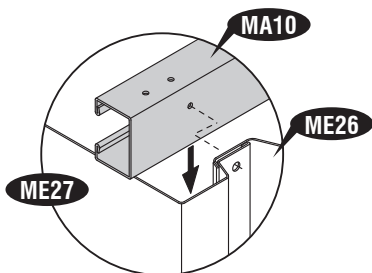
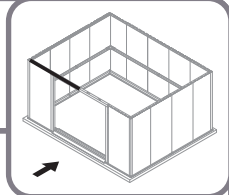

1

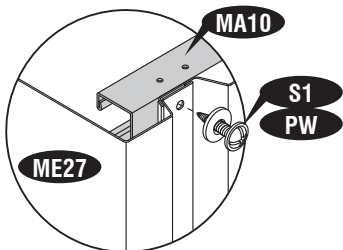

2

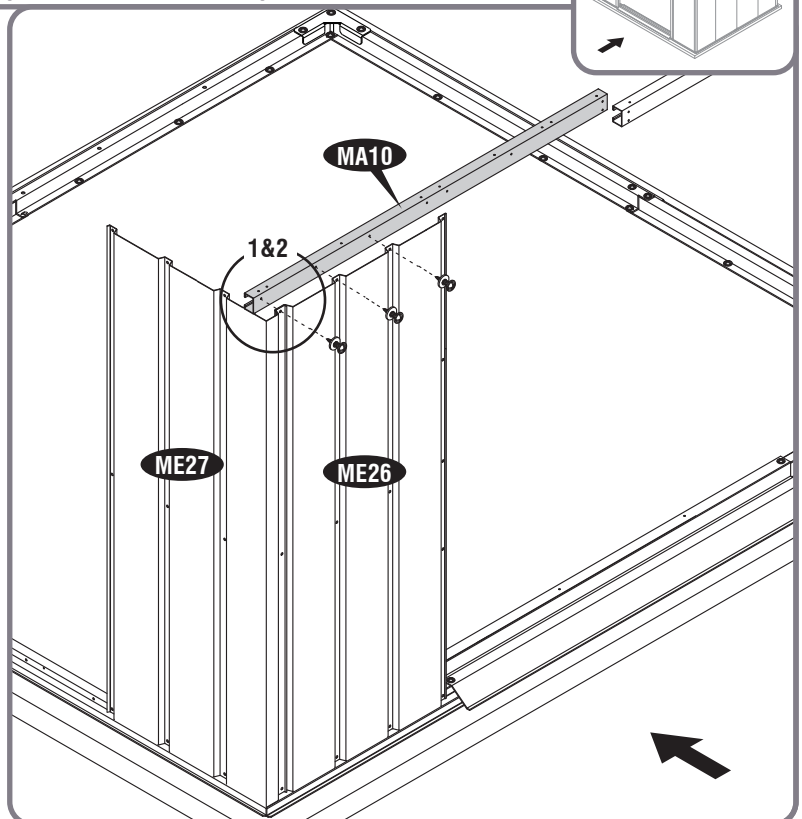

12

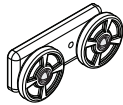

MA47 (x4)

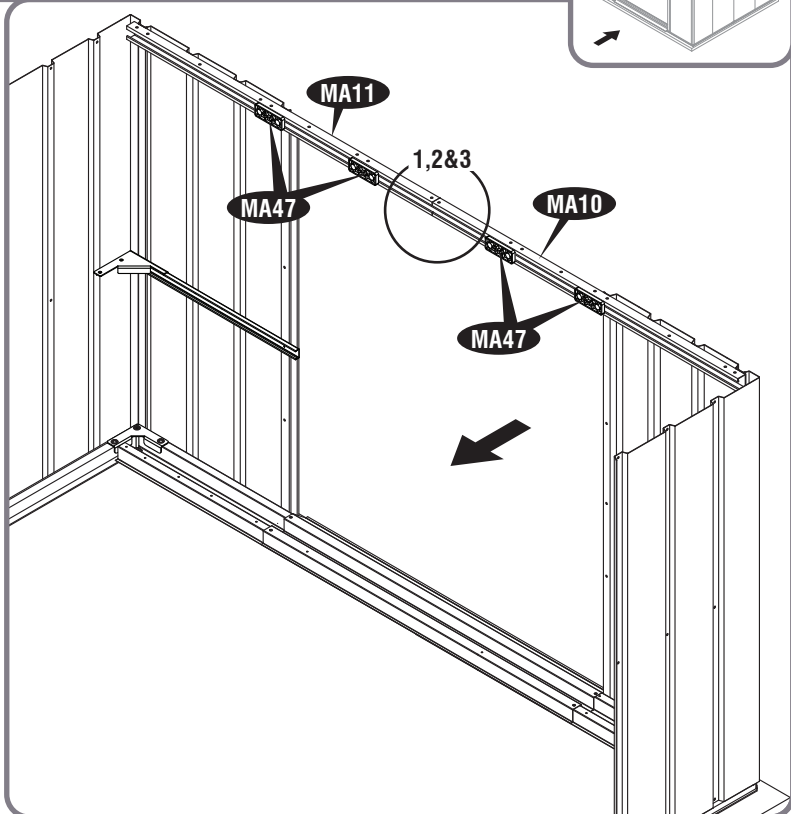
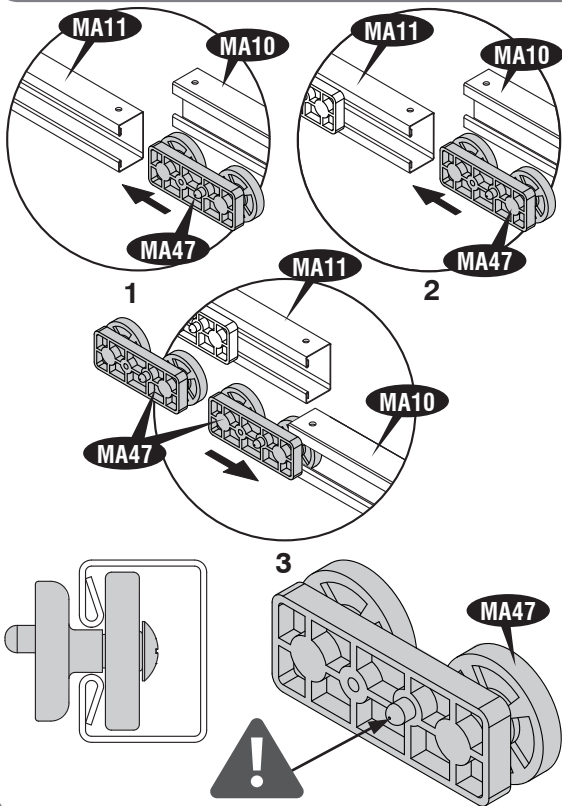
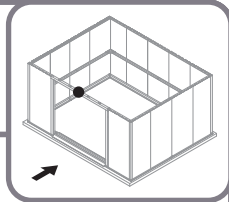

13

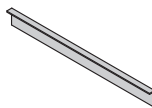

MA12 (x1)



S1 (x8)

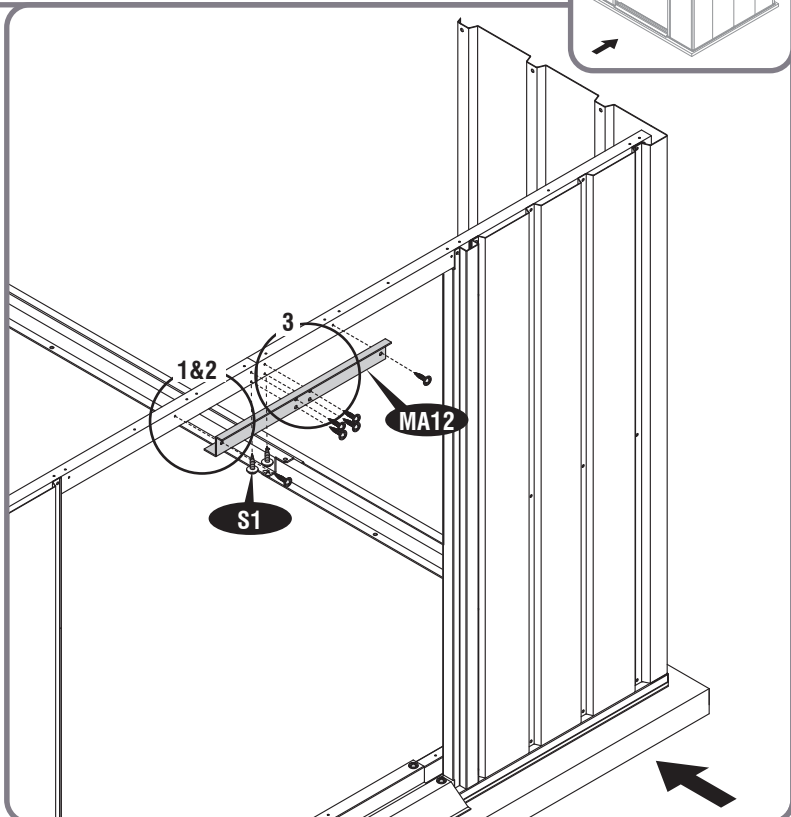
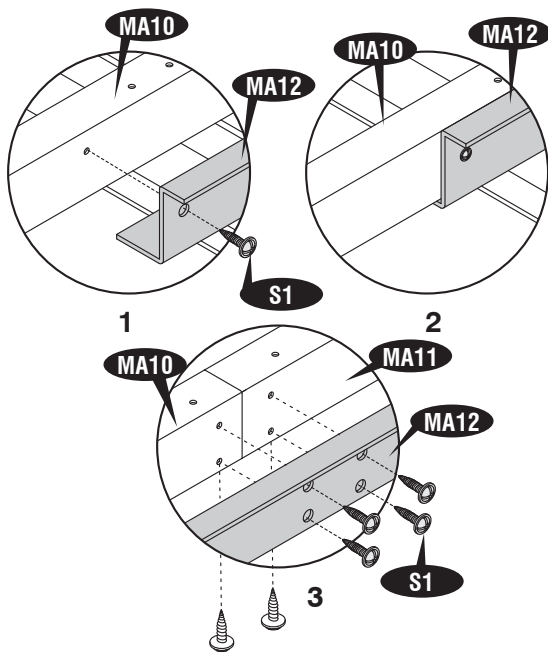
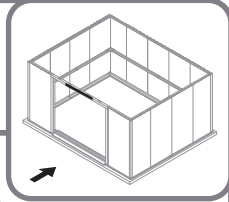

14

S1 (x3)

PW (x3)

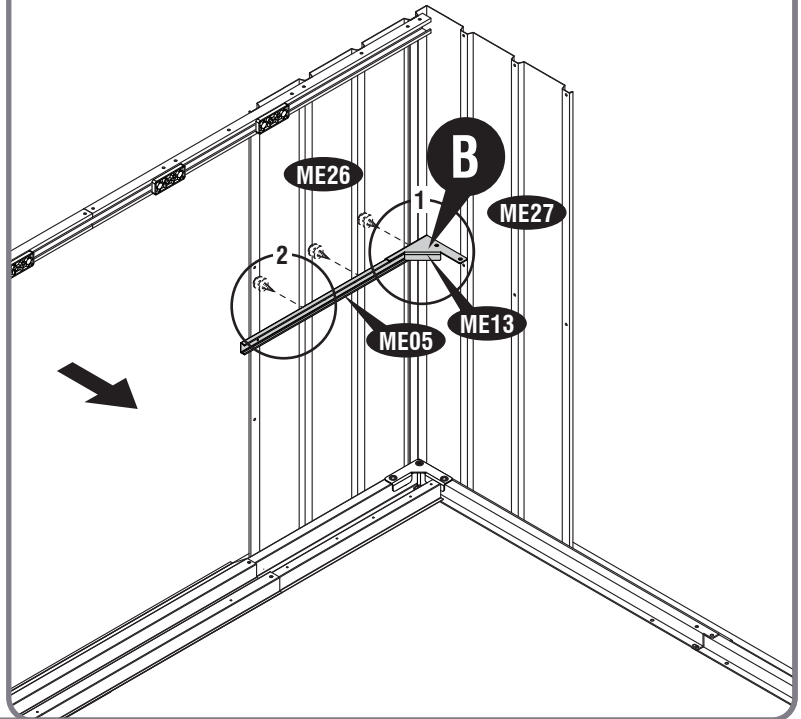
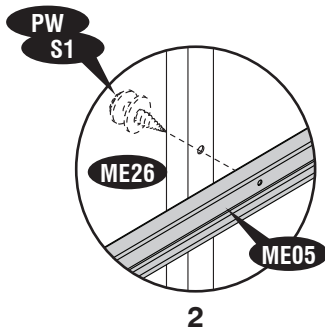
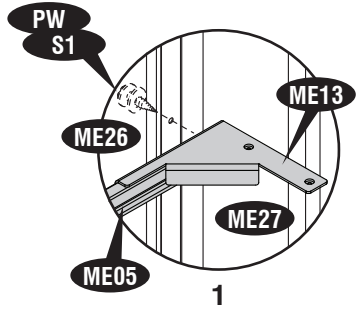
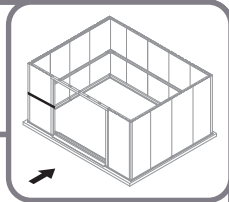

15

ME01 (x1)

S3 (x2)

S1 (x5)

PW (x7)

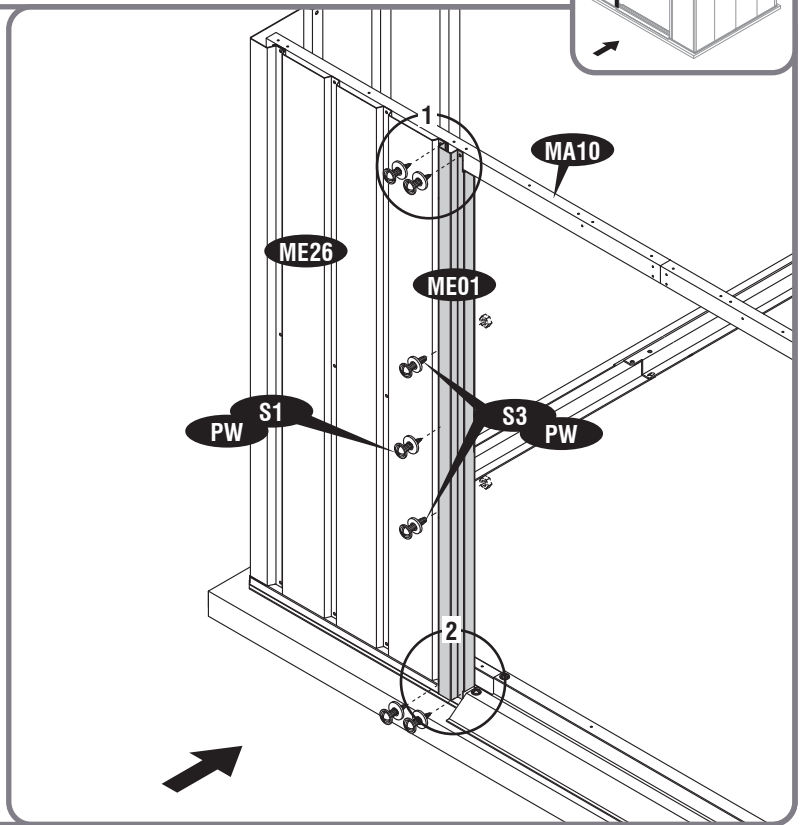
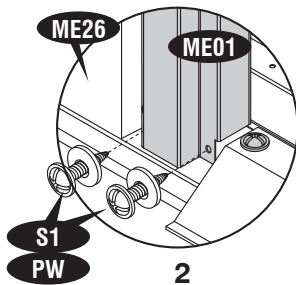
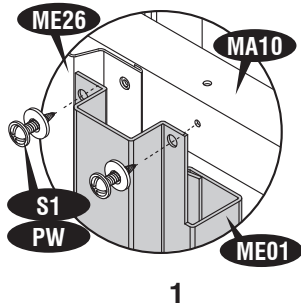
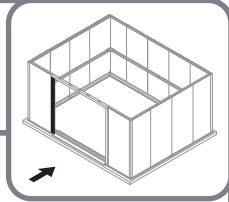

27

16

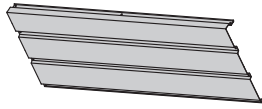

ME27 (x1)



S1 (x2)



PW (x2)

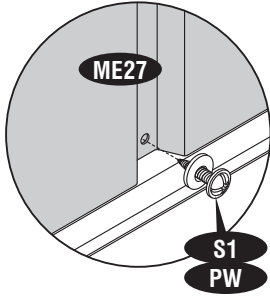
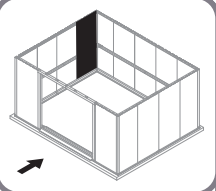

17

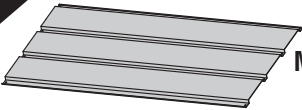

ME28 (x1)



S1 (x3)



PW (x3)

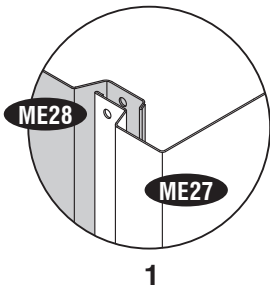
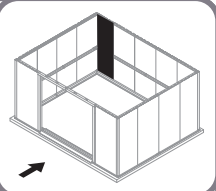

1

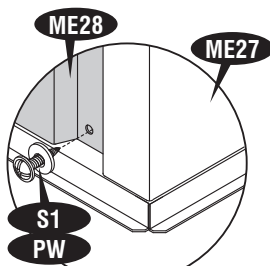

2

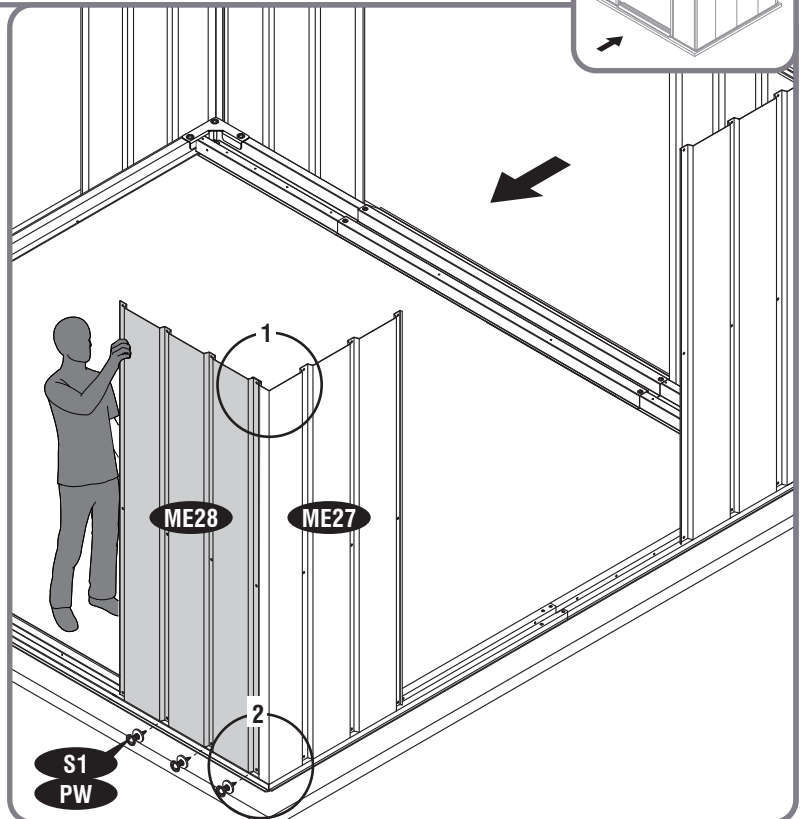

28

18

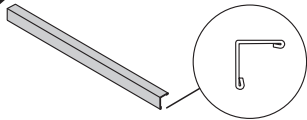

MA13 (x1)

S1 (x3)

PW (x3)

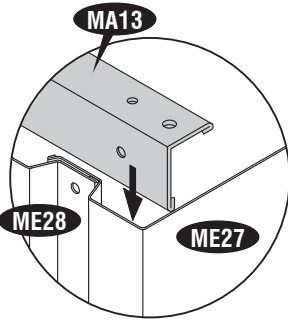
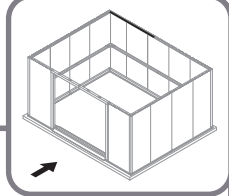

1

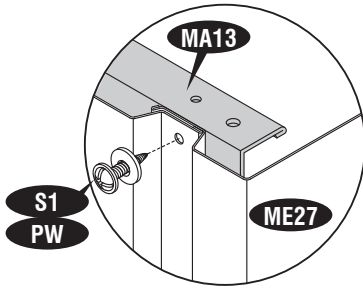

2

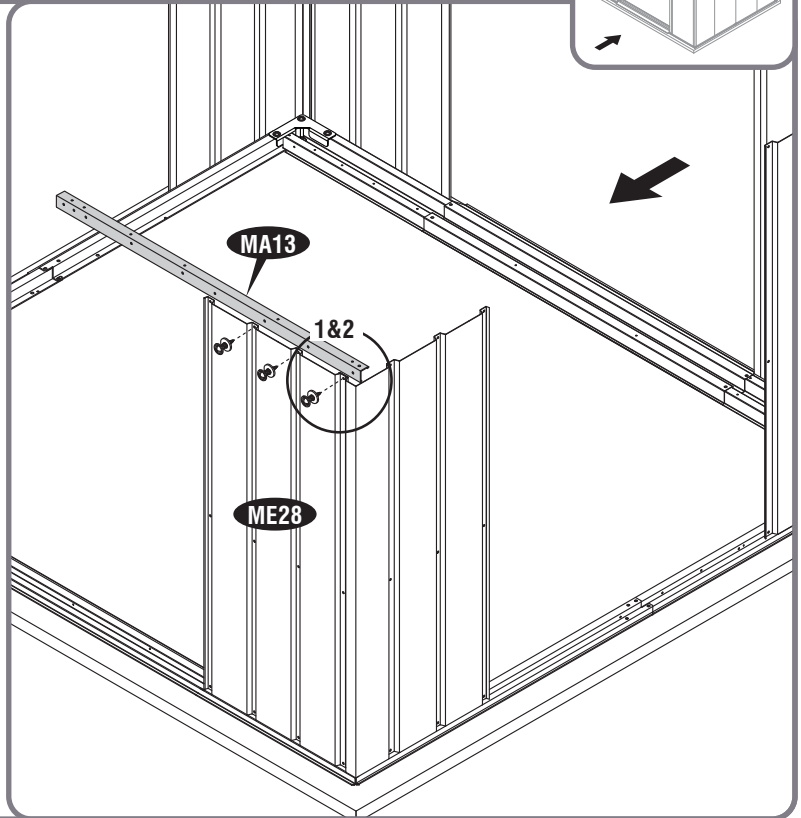

19

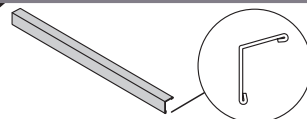

ME04 (x1)

S1 (x2)

PW (x2)

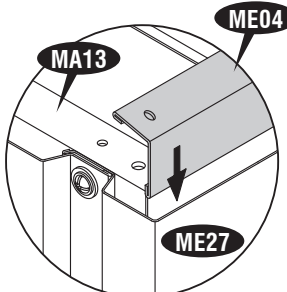
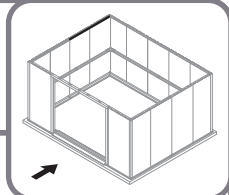

1

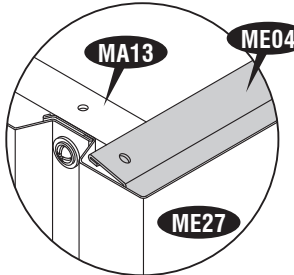

2

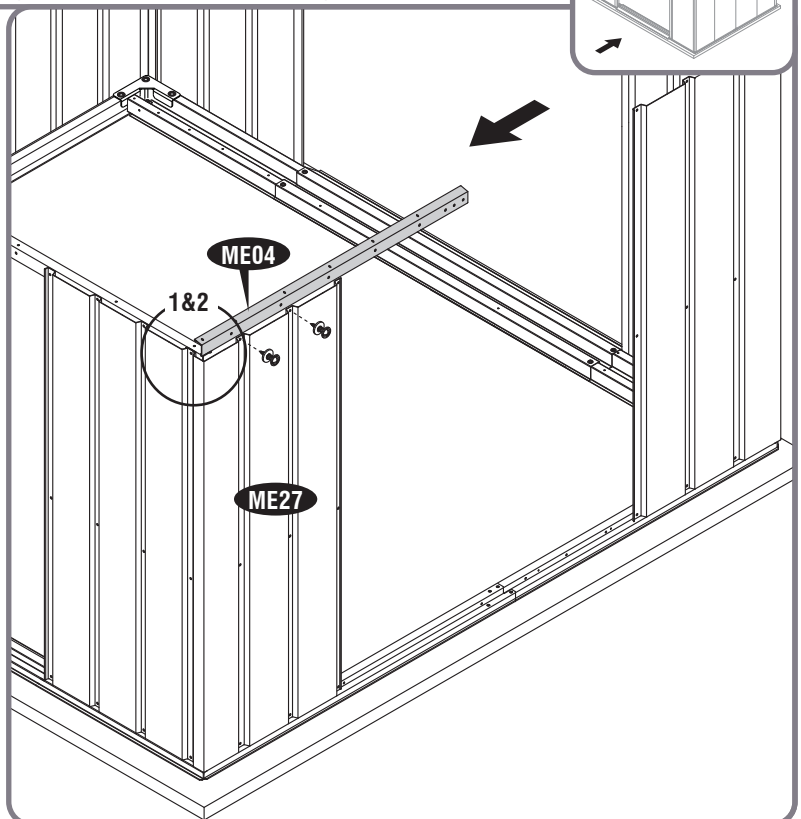

29

20

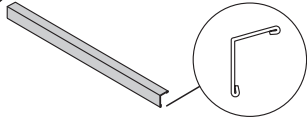

ME03 (x1)

S1 (x4)

PW (x2)

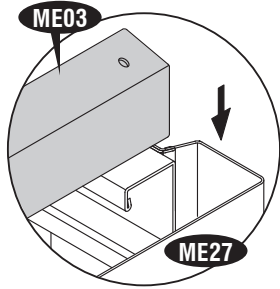
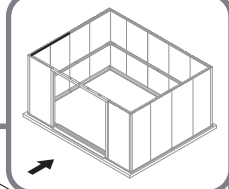

1

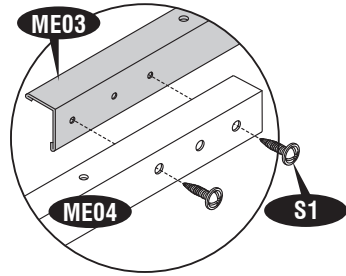

2

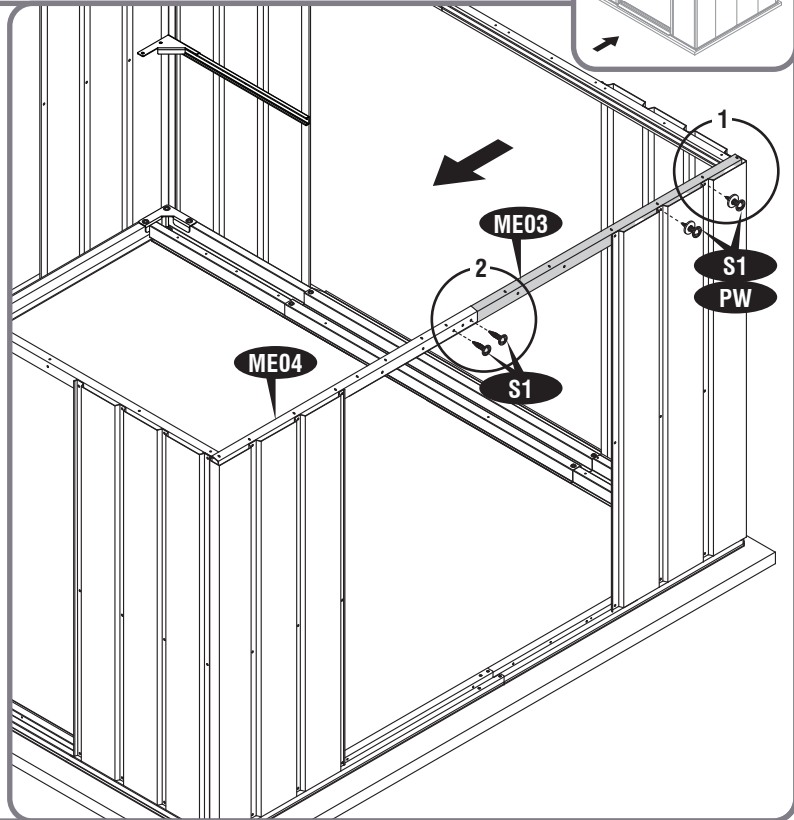

21

S1 (x6)

PW (x4)

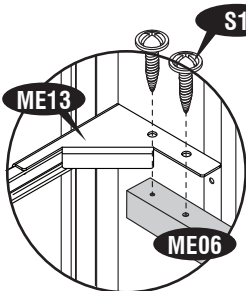
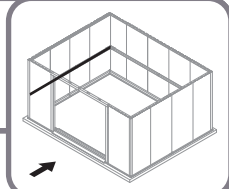

1

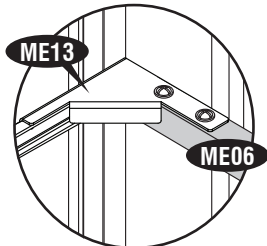

2

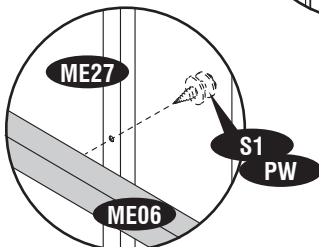

3

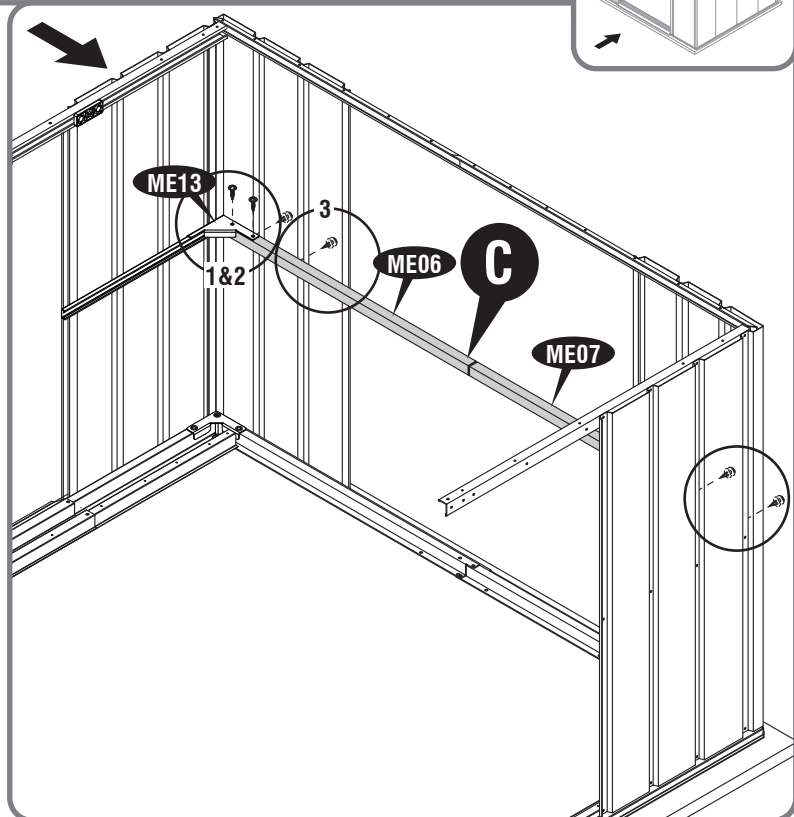

30

22

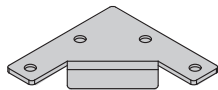

ME11 (x1)



S1 (x2)

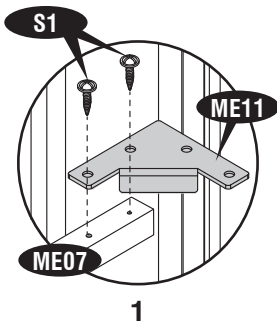
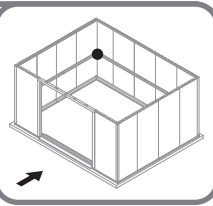

1

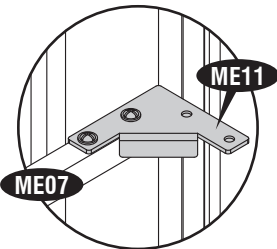

2

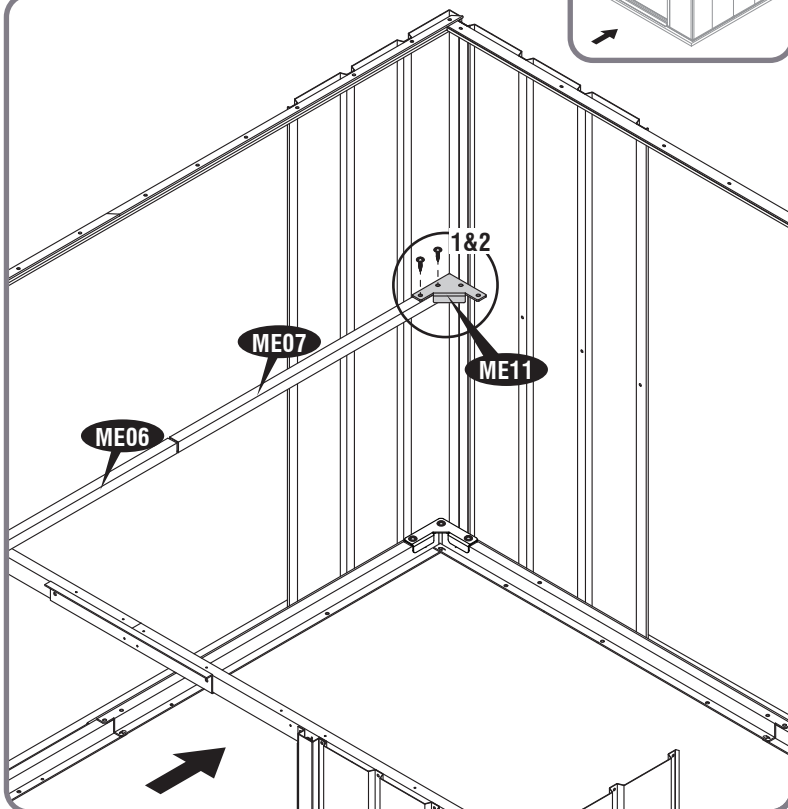

23

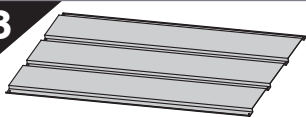

ME28 (x1)



S1 (x9)



PW (x9)

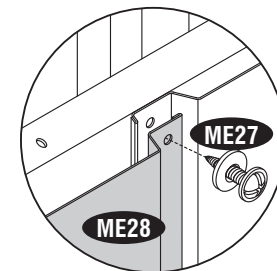
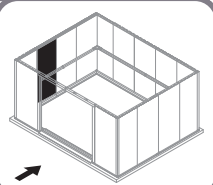

1

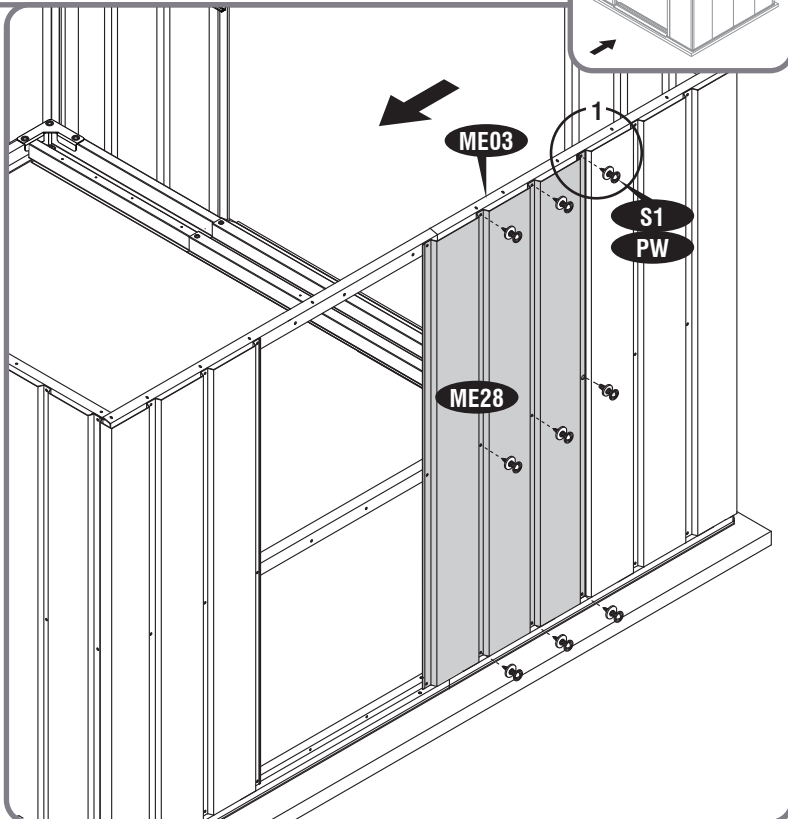

31

24

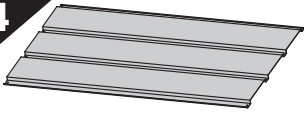

ME28 (x1)



S1 (x12)



PW (x12)

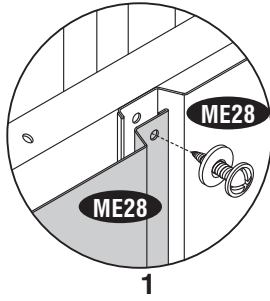
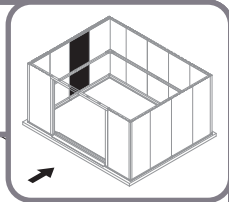

1

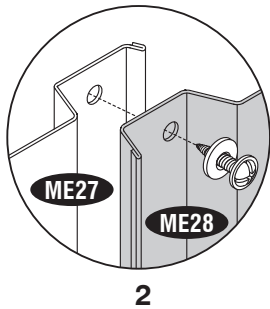

2

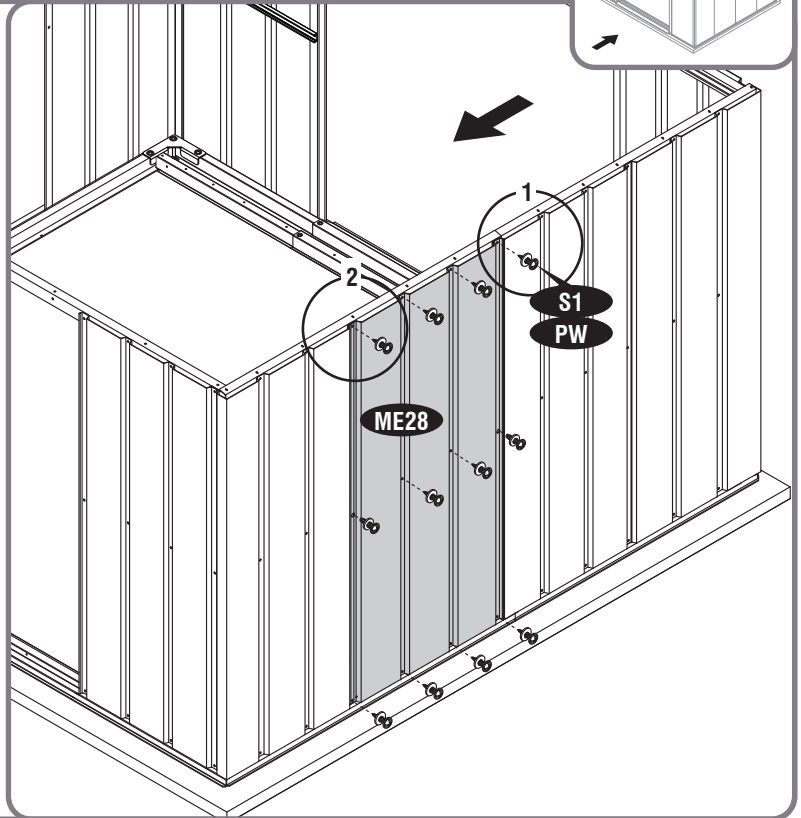

25

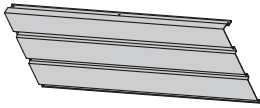

ME27 (x1)



S1 (x2)



PW (x2)

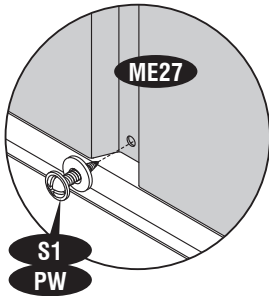
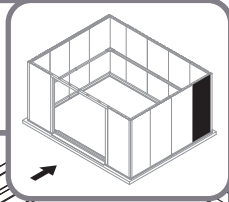

S1
PW

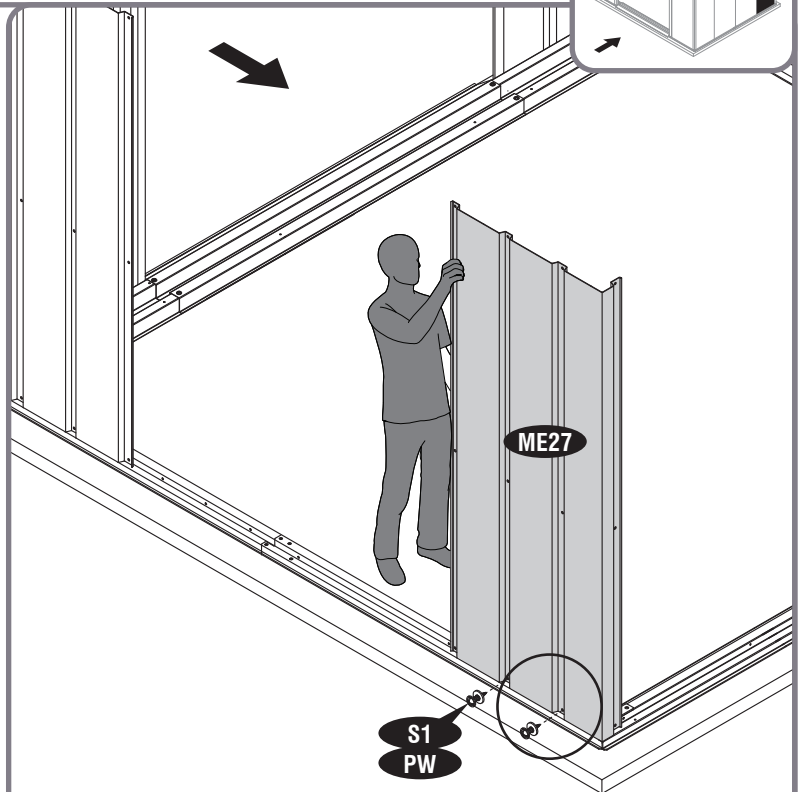

S1
PW

32

26

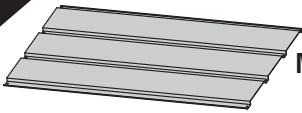

ME28 (x1)



S1 (x3)



PW (x3)

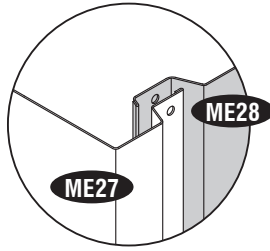
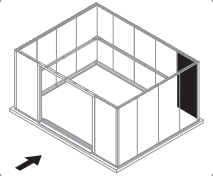

1

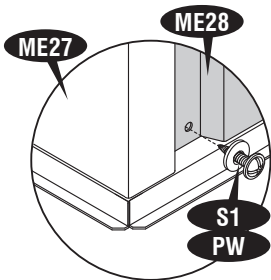

2

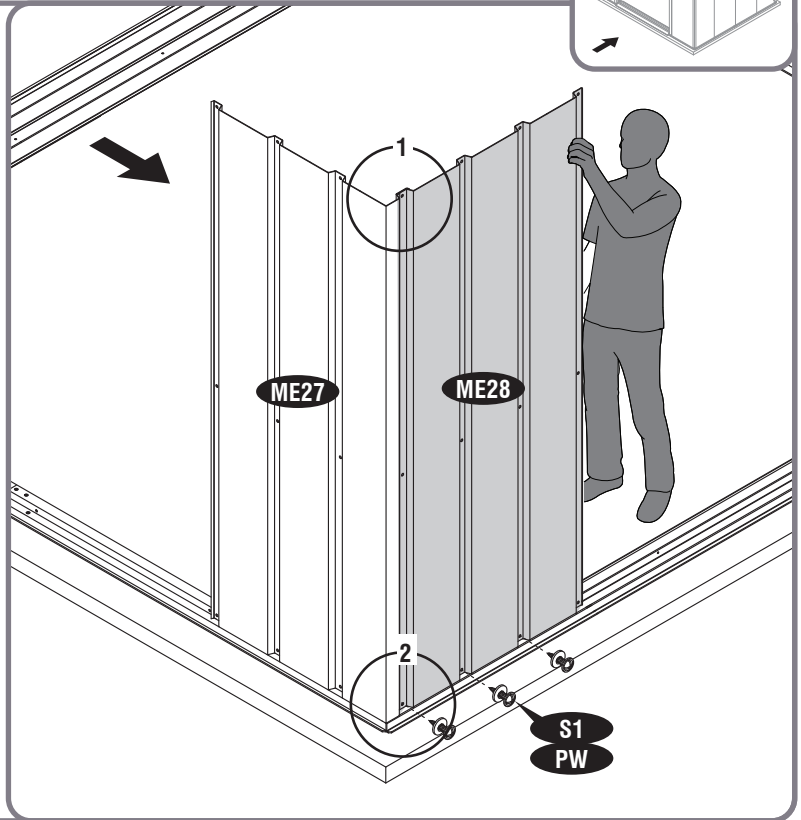

27

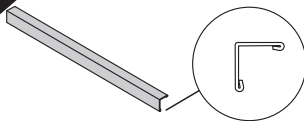

MA14 (x1)



S1 (x5)



PW (x3)

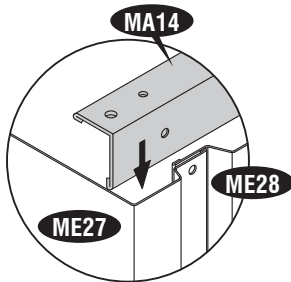
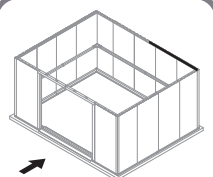

1

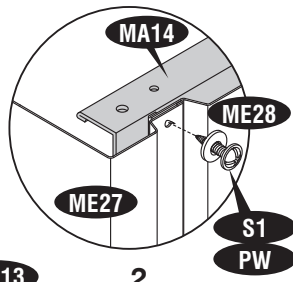

2

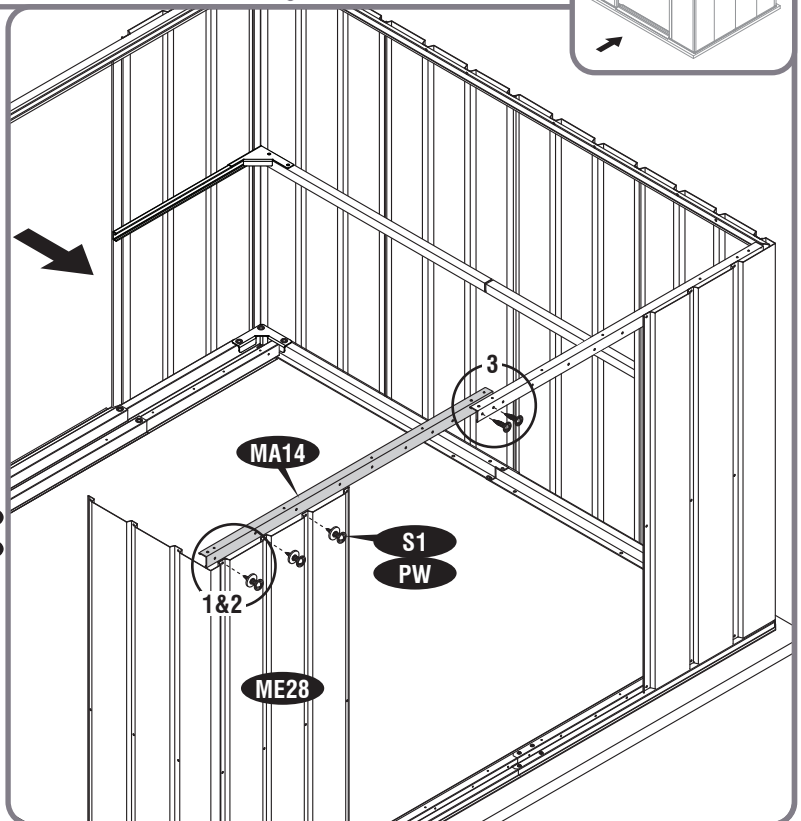
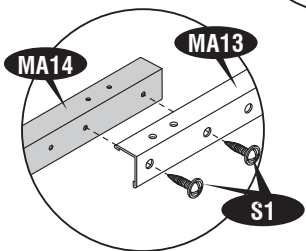

33

28

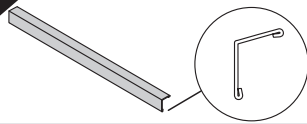

ME04 (x1)

S1 (x2)

PW (x2)

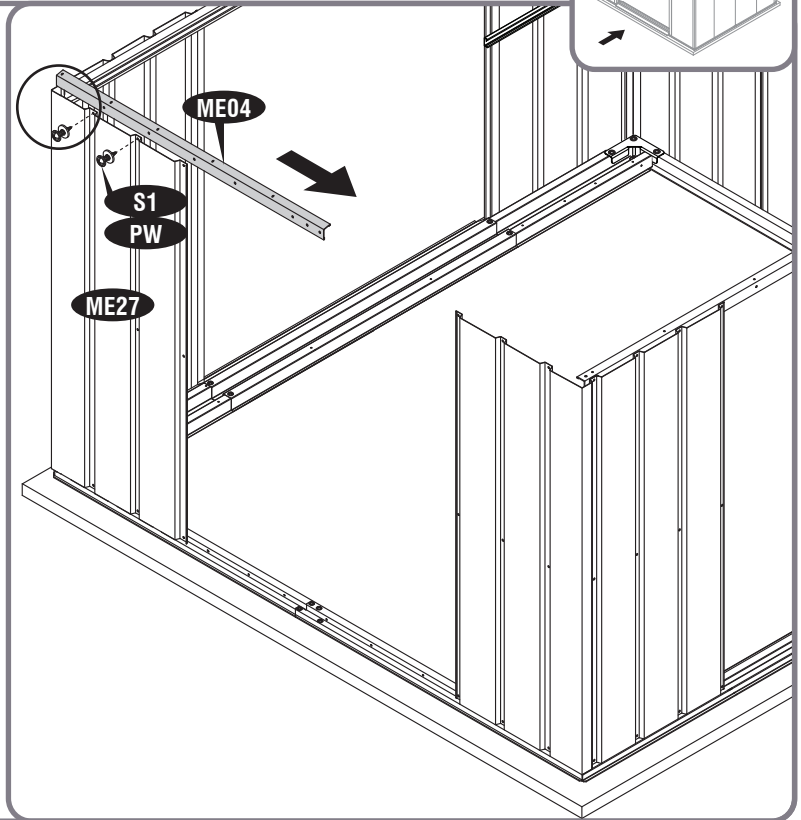
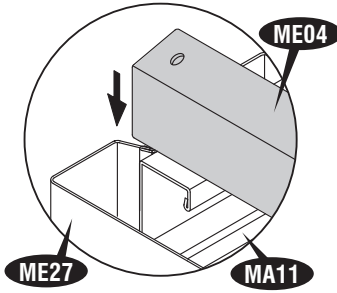
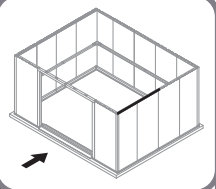

29

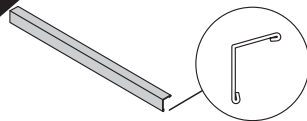

ME03 (x1)

S1 (x4)

PW (x2)

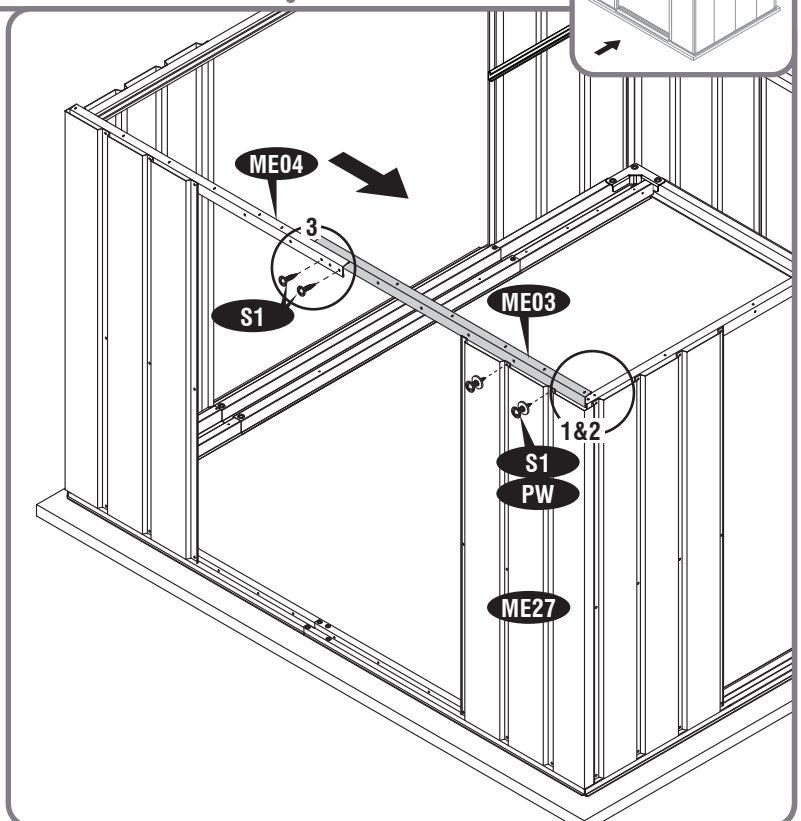
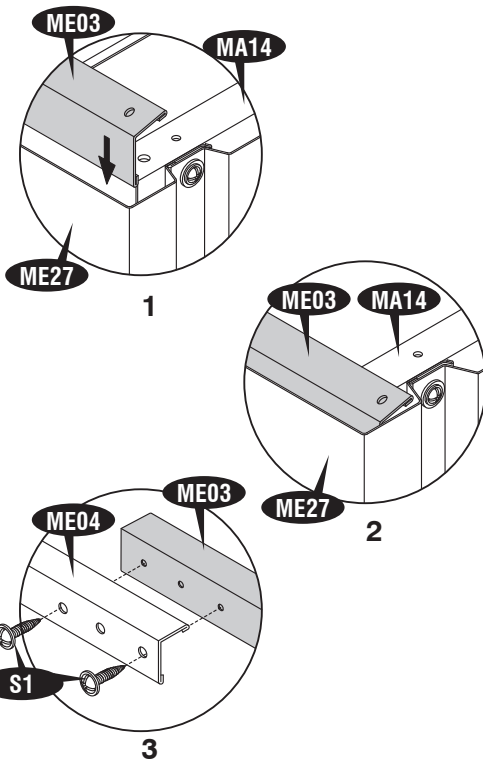
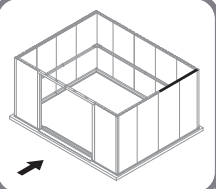

34

30

S1 (x6)

PW (x4)

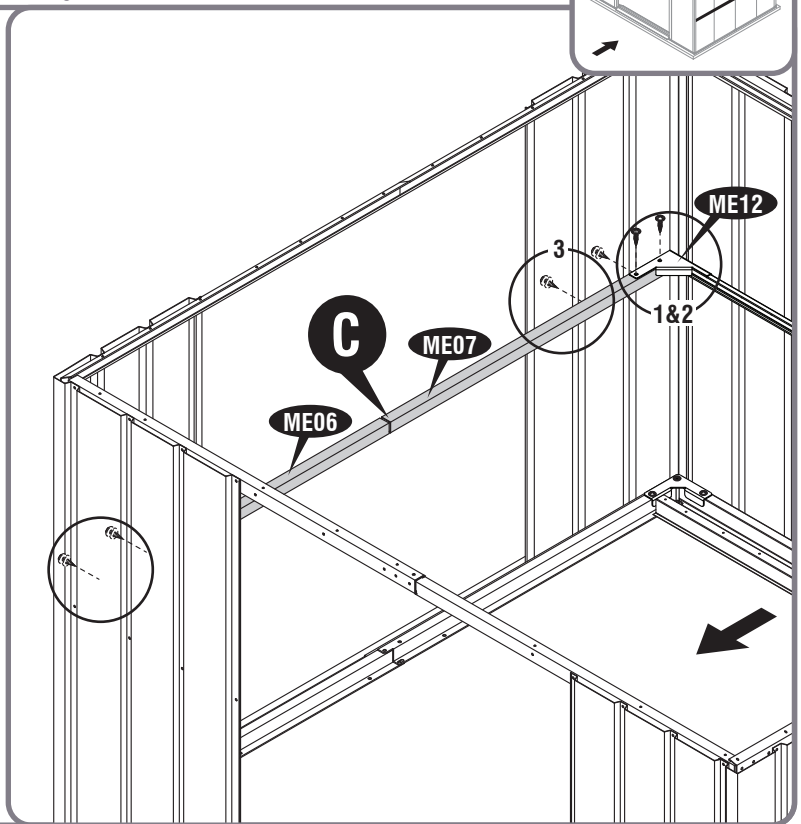
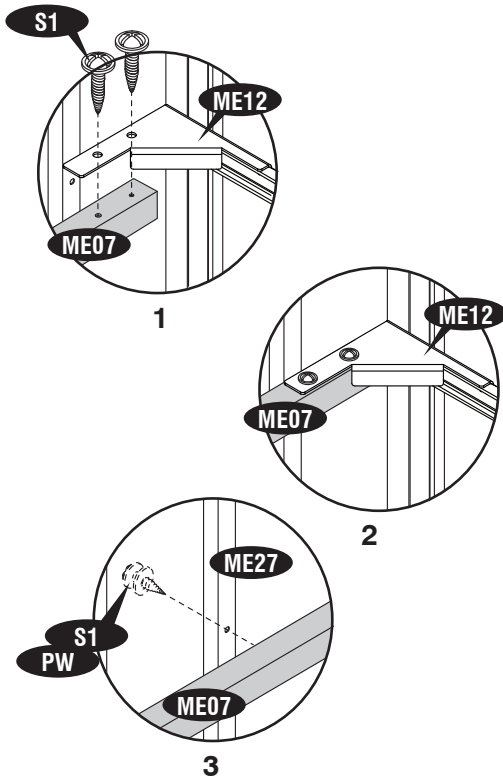
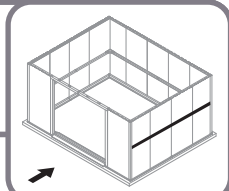

31

ME11 (x1)

S1 (x2)

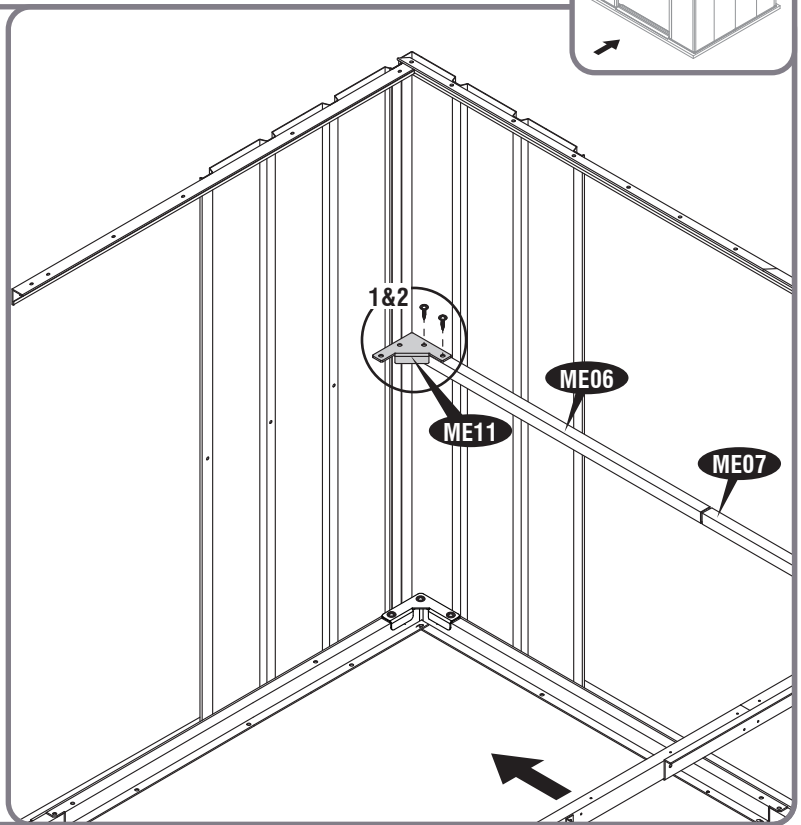
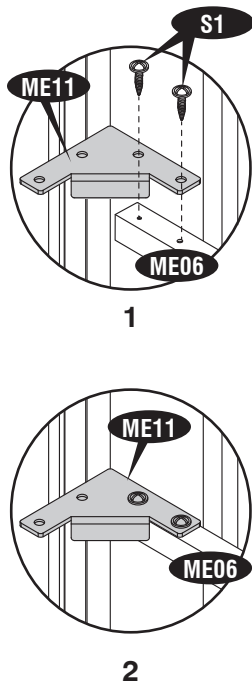
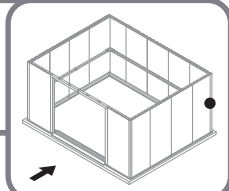

35

32

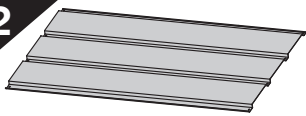

ME28 (x1)



S1 (x9)



PW (x9)

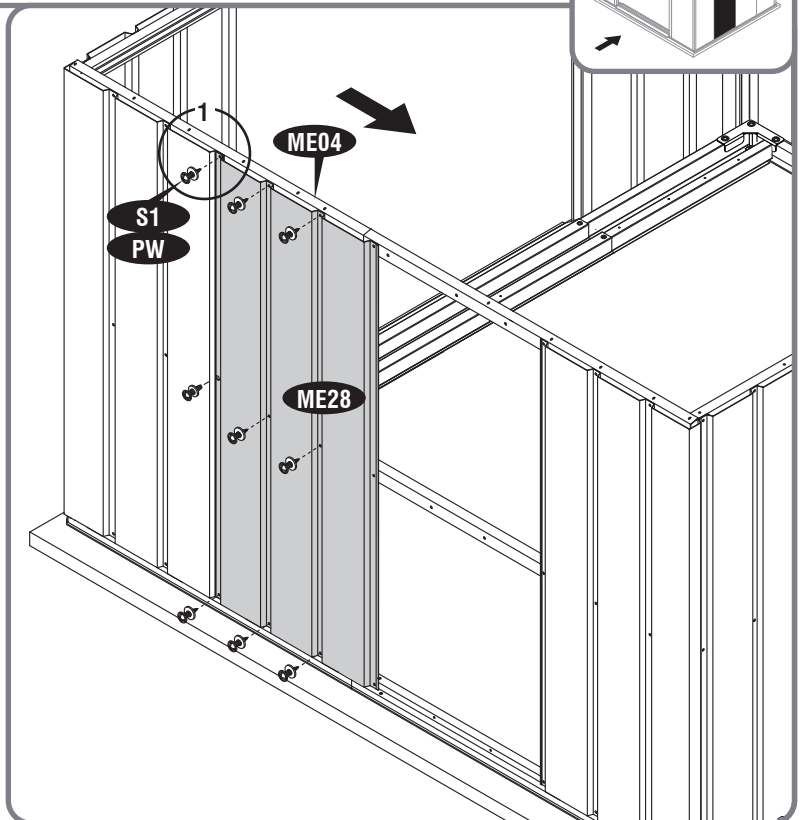
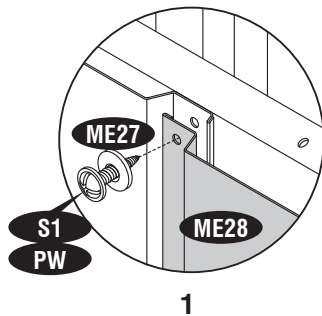
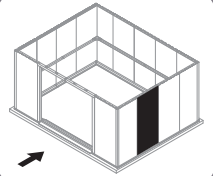

33

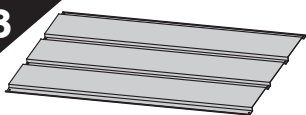

ME28 (x1)



S1 (x12)



PW (x12)

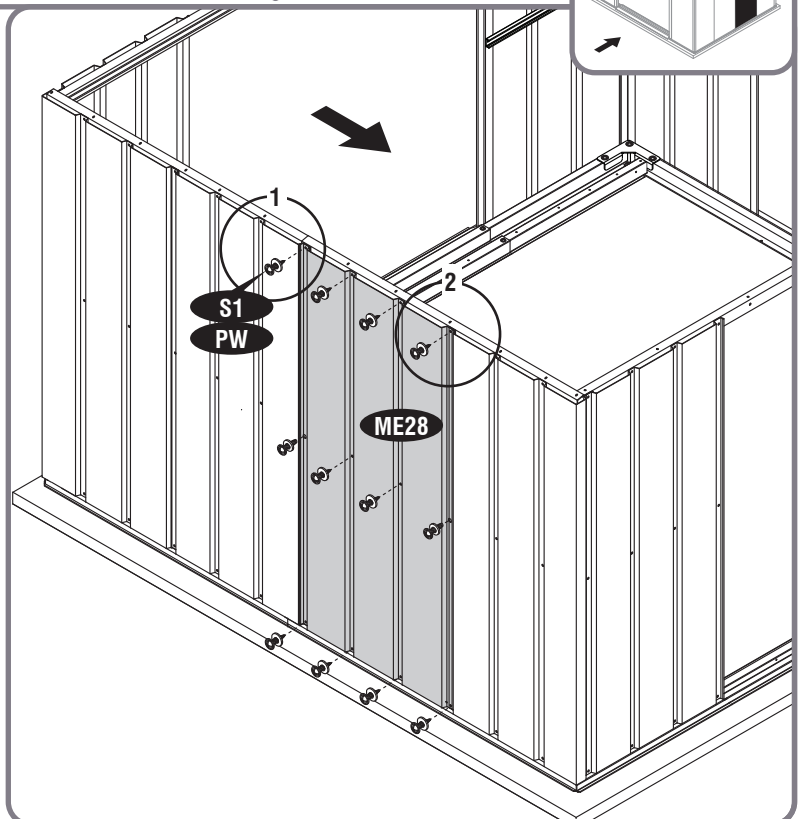
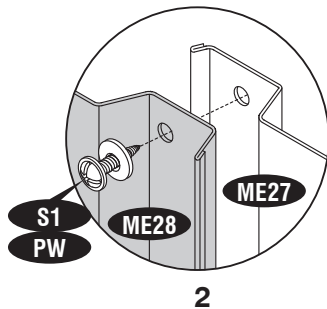
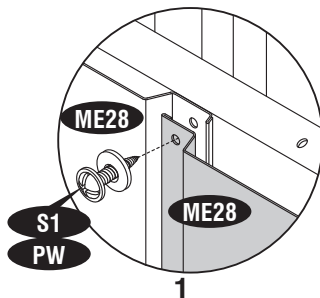
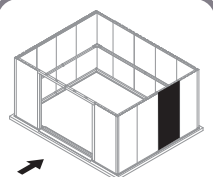

36

34

S1 (x10)

PW (x6)

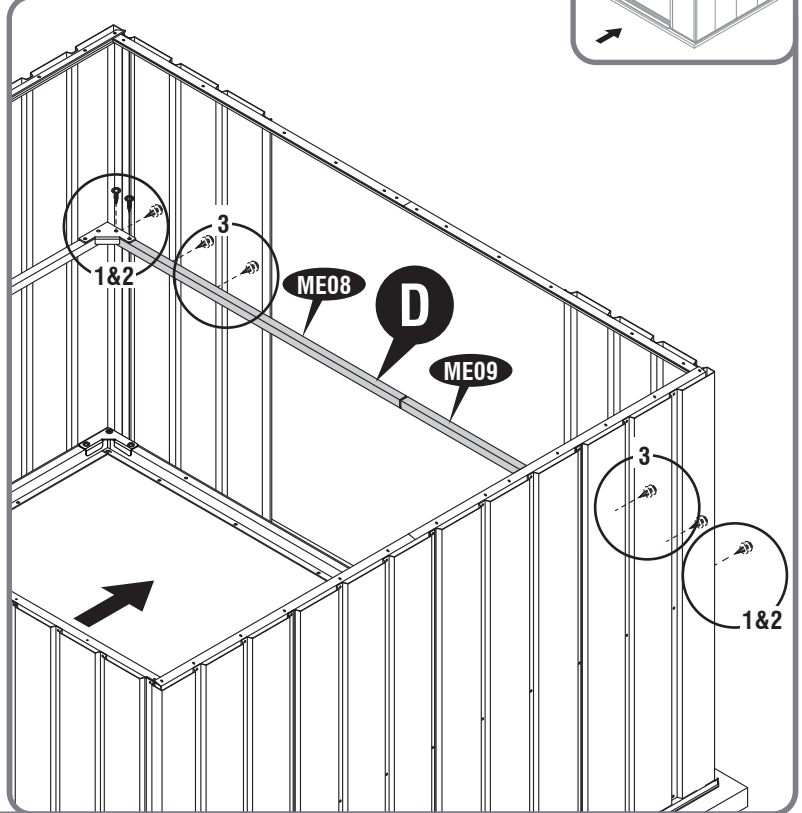
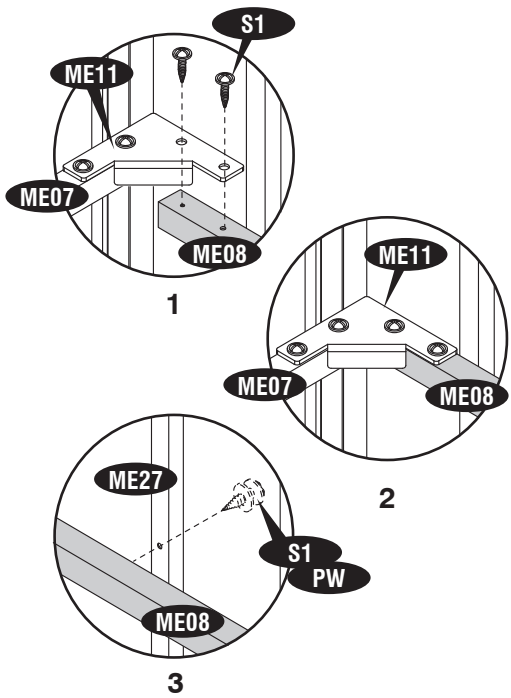
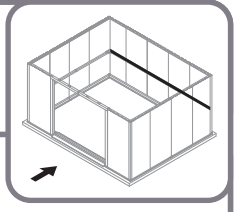

35

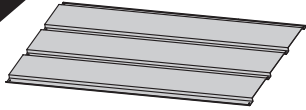

ME28 (x1)

S1 (x9)

PW (x9)

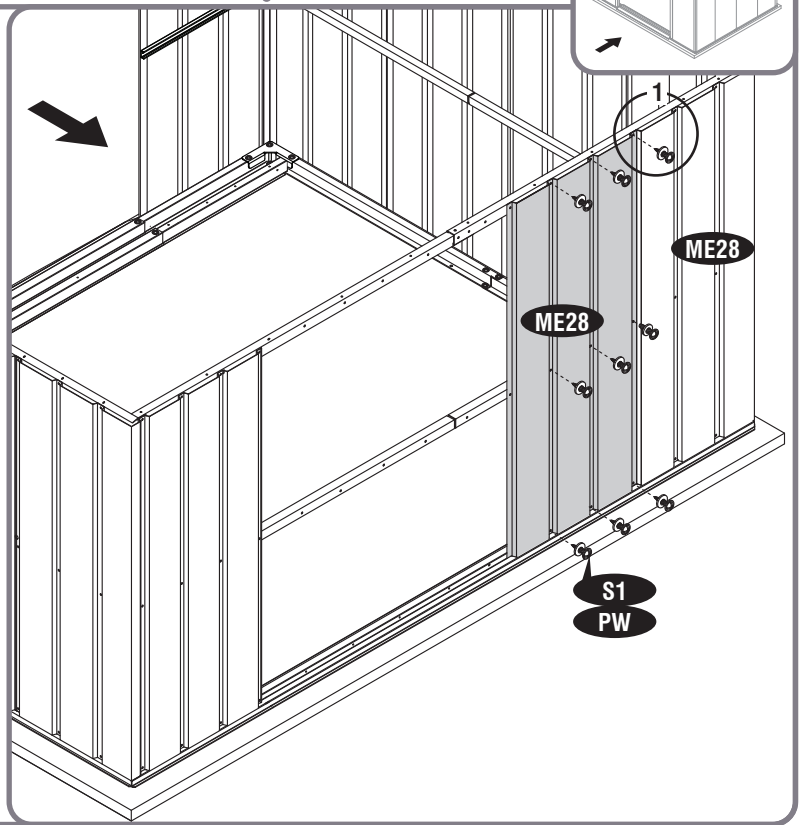
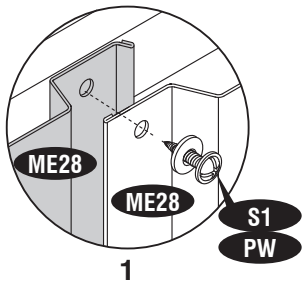
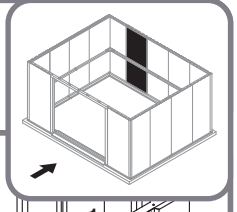

37

36

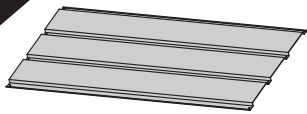

ME28 (x1)



S1 (x9)



PW (x9)

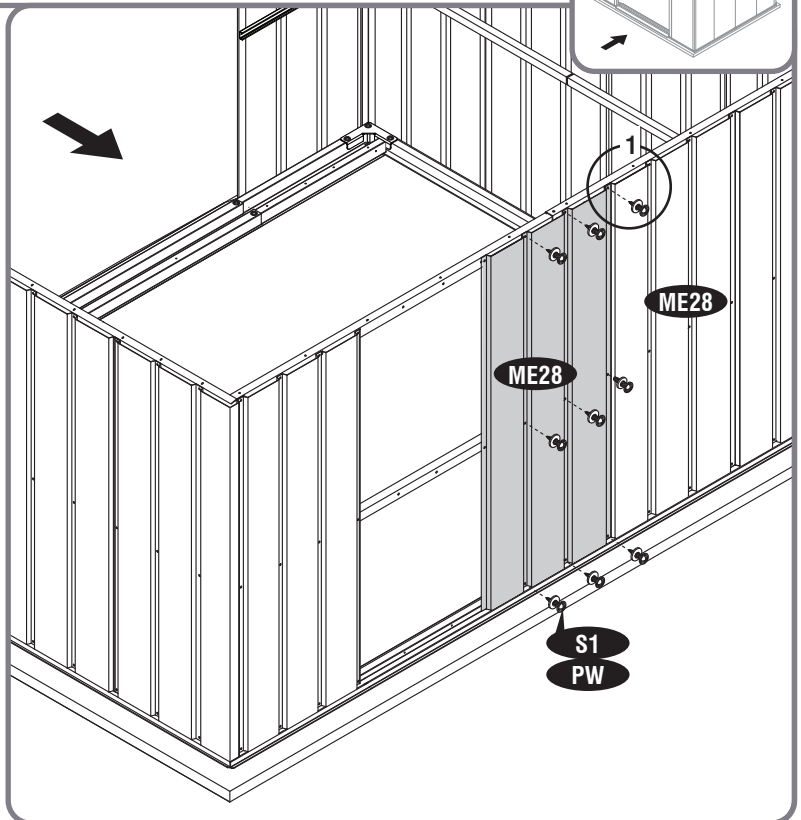
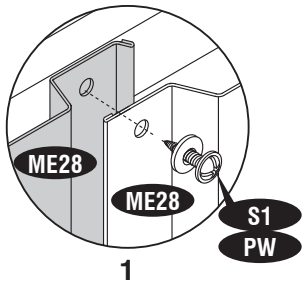
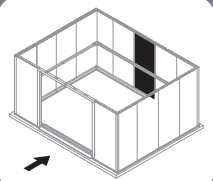

37

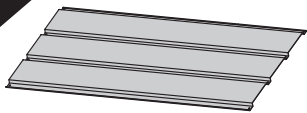

ME28 (x1)



S1 (x12)



PW (x12)

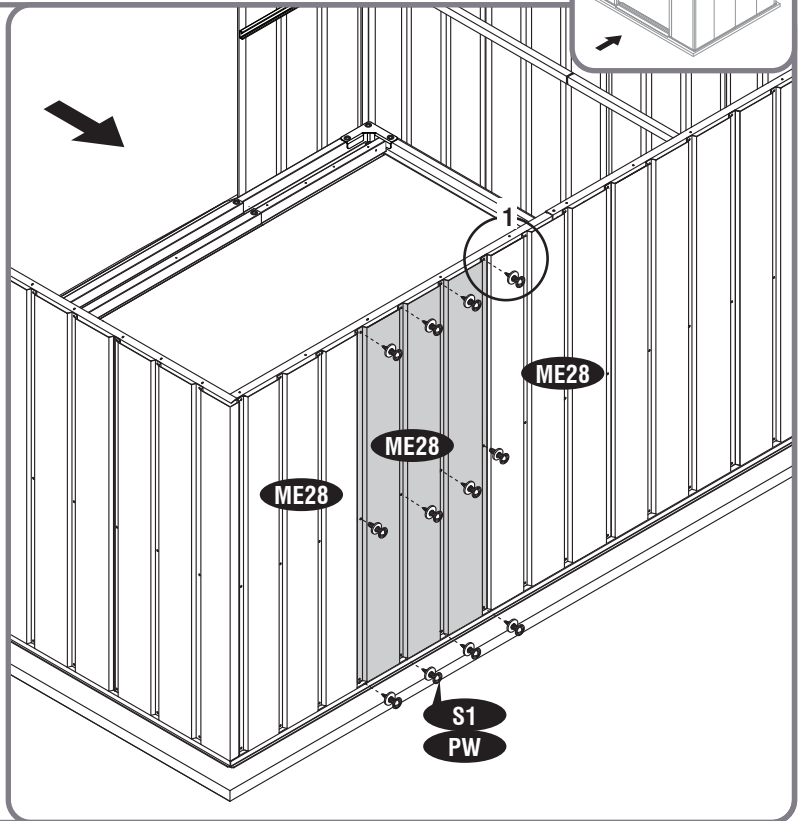
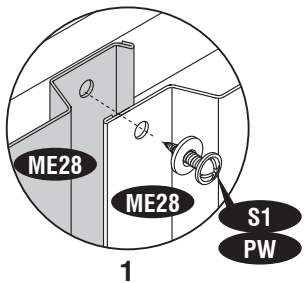
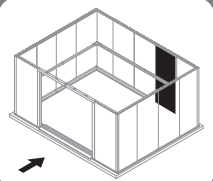

38

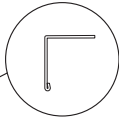
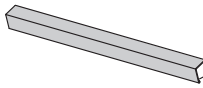

ME14 (x1)



S1 (x4)

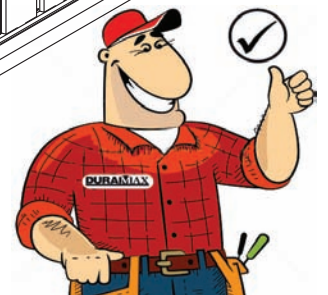
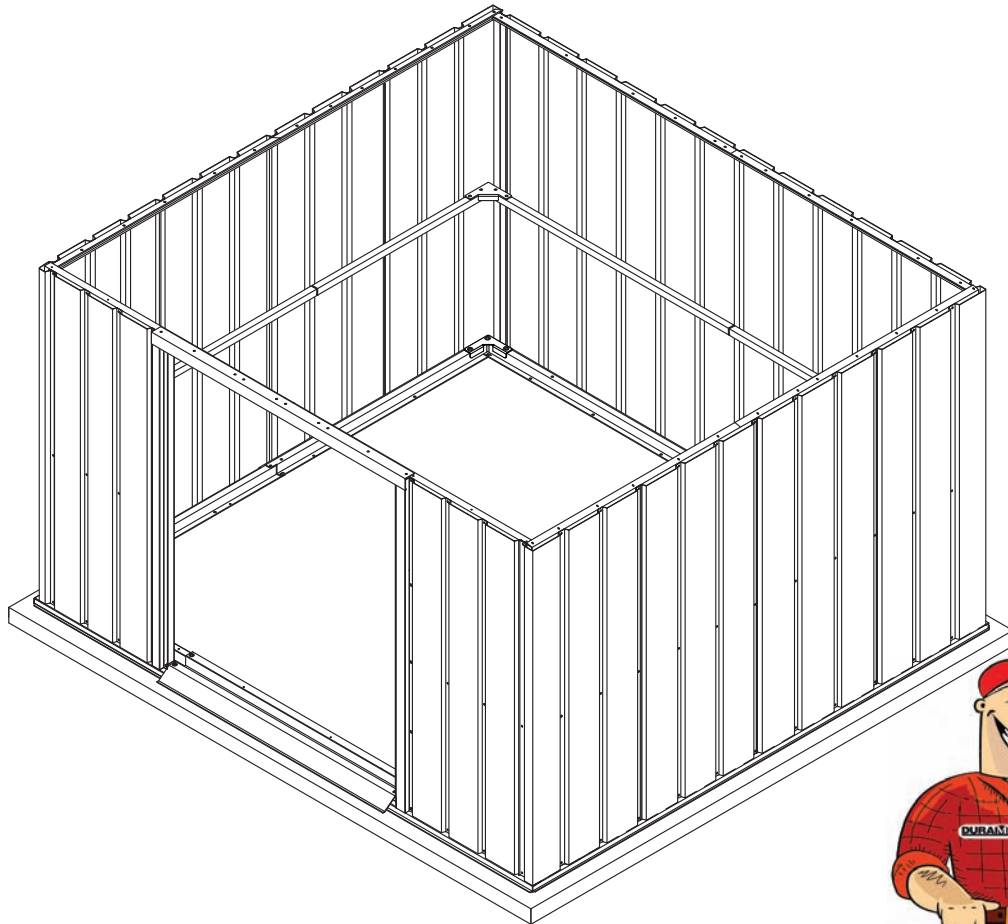
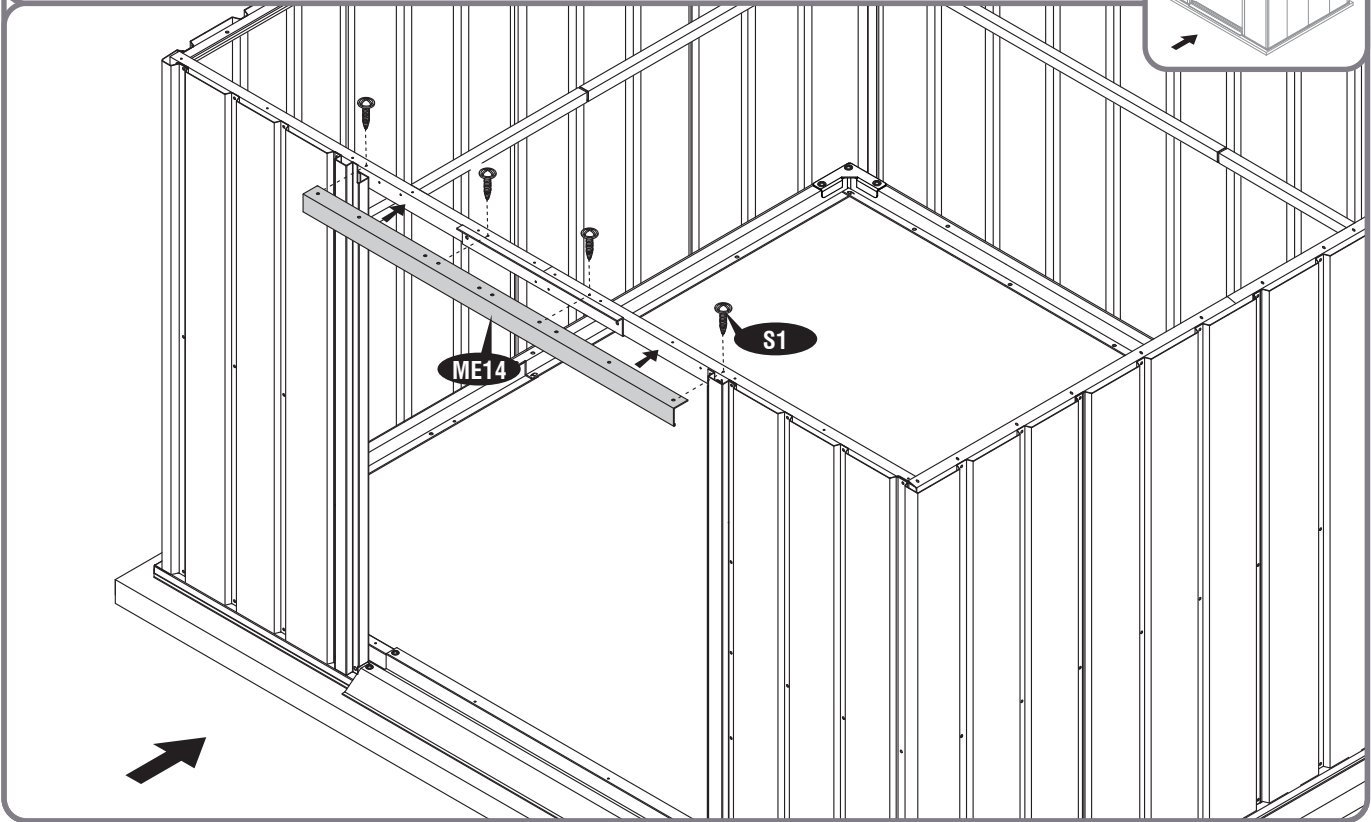
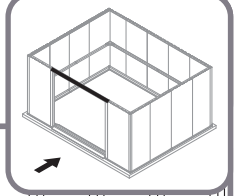



3

EN Roof	CS Střecha	IT Soffitto
FR Toit	SK Strecha	PL Dach
DE Dach	SL Streha	RO Acoperișul
ES El techo	HR Krov	BG Покрив
PT Telhado	HU Tető	TR Çatı
NL Dak	SV Tak	

EN Parts needed	CS Potřebné součásti	IT Parti occorrenti
FR Pièces nécessaires	SK Potřebné časti	PL Niezbędne elementy
DE Benötigte Teile	SL Dele, ki jih boste potrebovali	RO Elementele componente necesare
ES Las partes necesarias	HR Dijelovi potreban	BG Необходими части
PT Peças Necessárias	HU Szükséges részek	TR Gerekli parçalar
NL Onderdelen nodig	SV Delar som behövs	

MA18	2
ME15	2
ME16	4
ME17	4
ME18	2
ME19	2

ME20	2
ME21	2
MA26	4
ME22	2
ME25	2
ME29	2

ME30	2
ME31	2
ME32	4
ME33	2
MA49	2

TC	4
PW	140
F1	28
S1	118
S2	74
S3	72
S8	28



1

ME30 (x1)

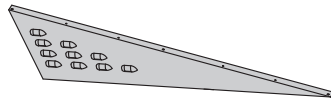

S1 (x5)

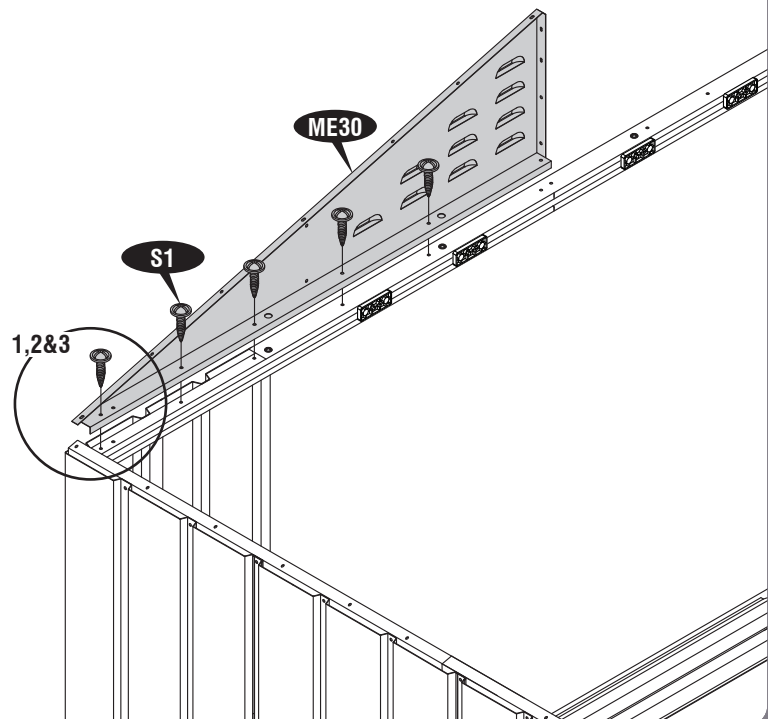
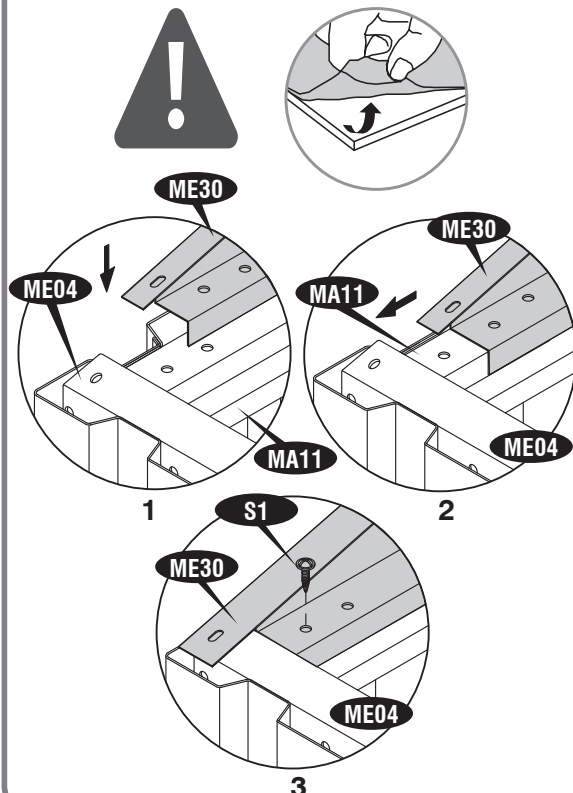
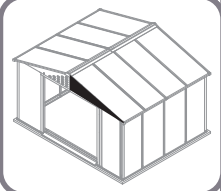

2

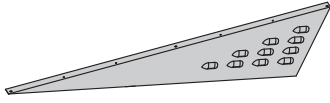

ME29 (x1)



S1 (x5)

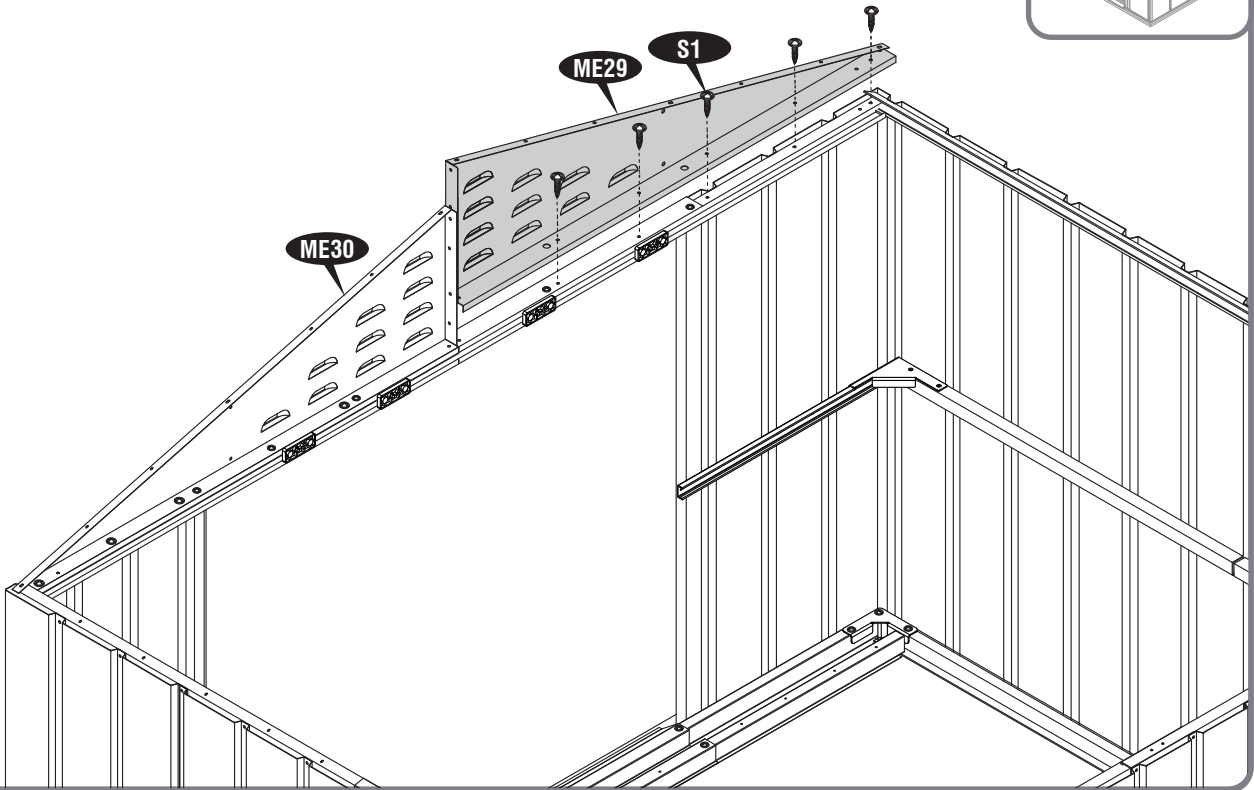
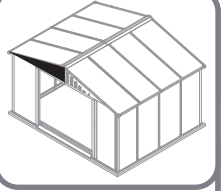

3

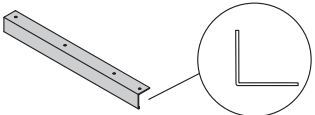

ME15 (x1)



S3 (x1)

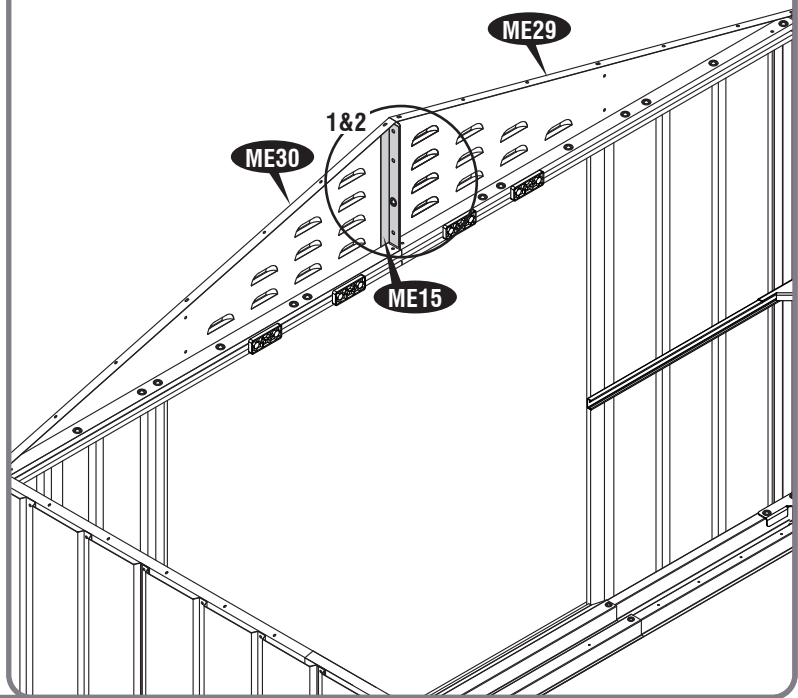
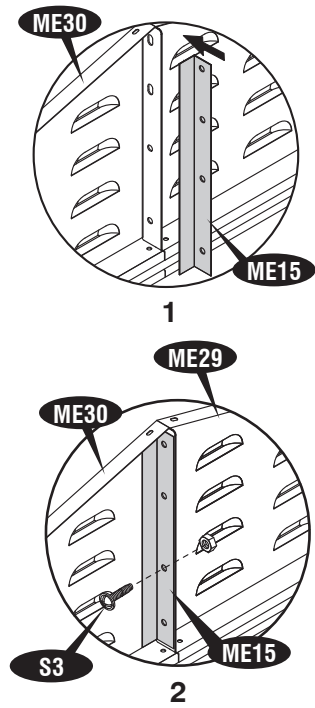
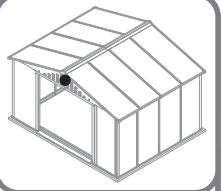

4

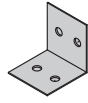

MA18 (x2)



S1 (x2)



S3 (x1)

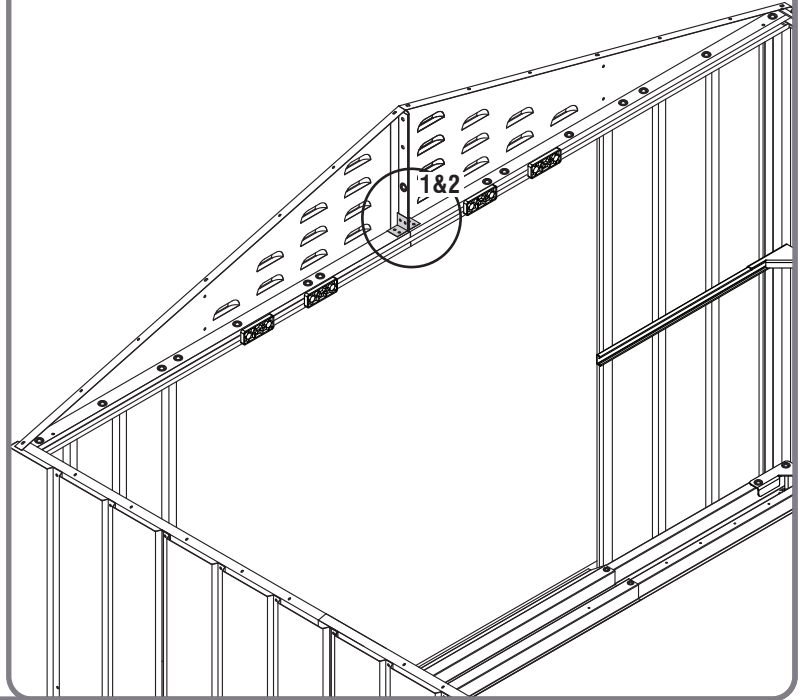
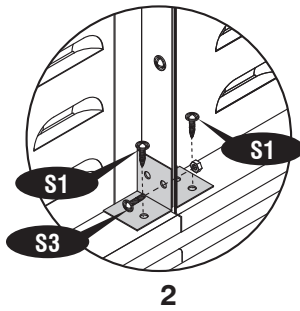
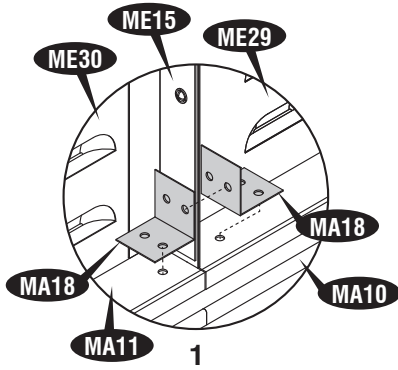
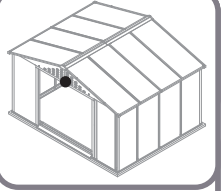

5

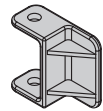

MA49 (x2)



S1 (x4)

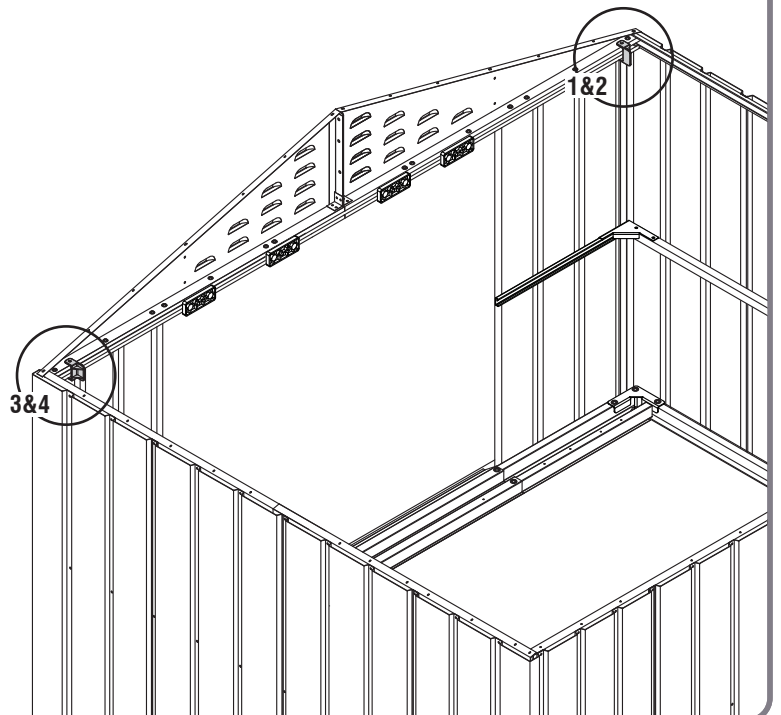
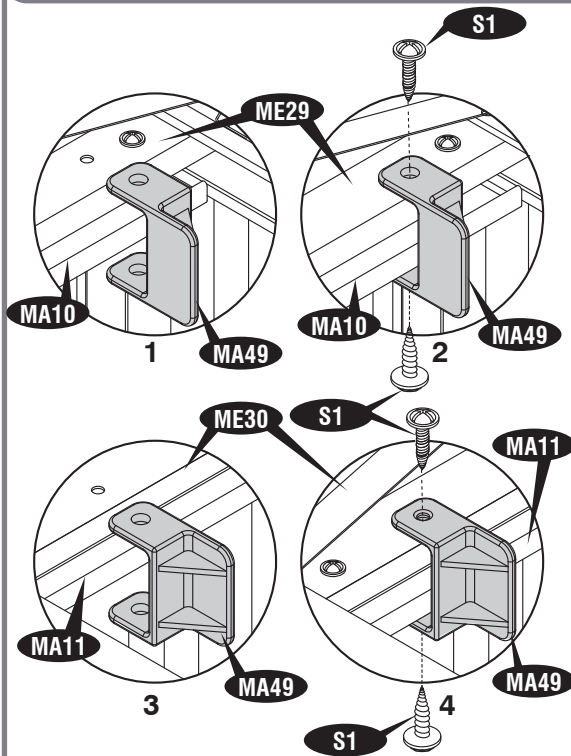
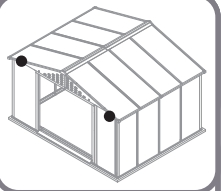

6

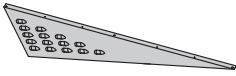

ME30 (x2)

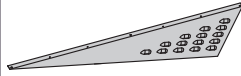

ME29 (x2)



S1 (x12)

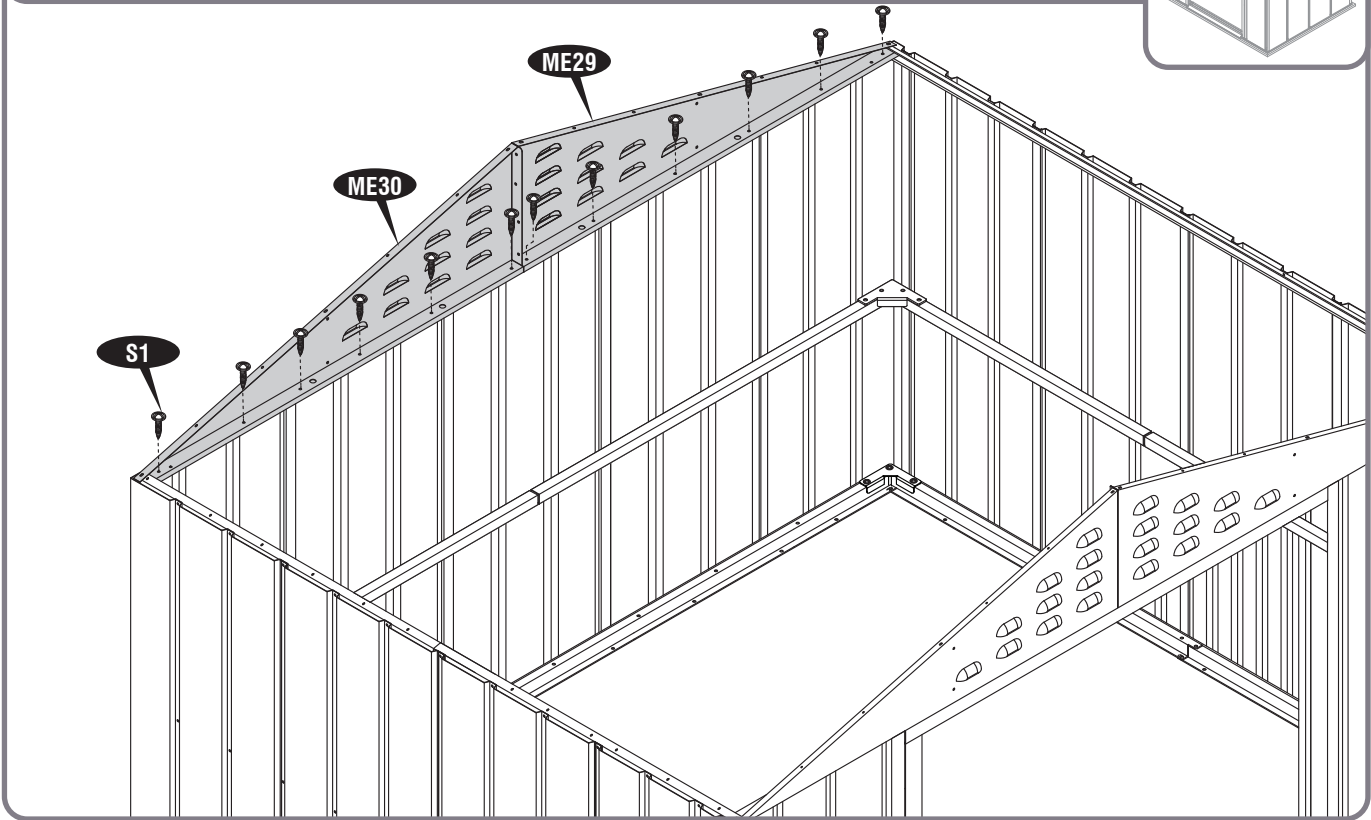
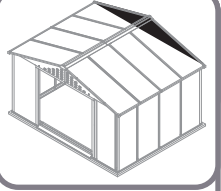

7

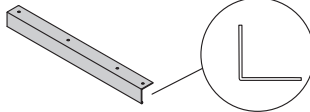

ME15 (x1)



S3 (x2)

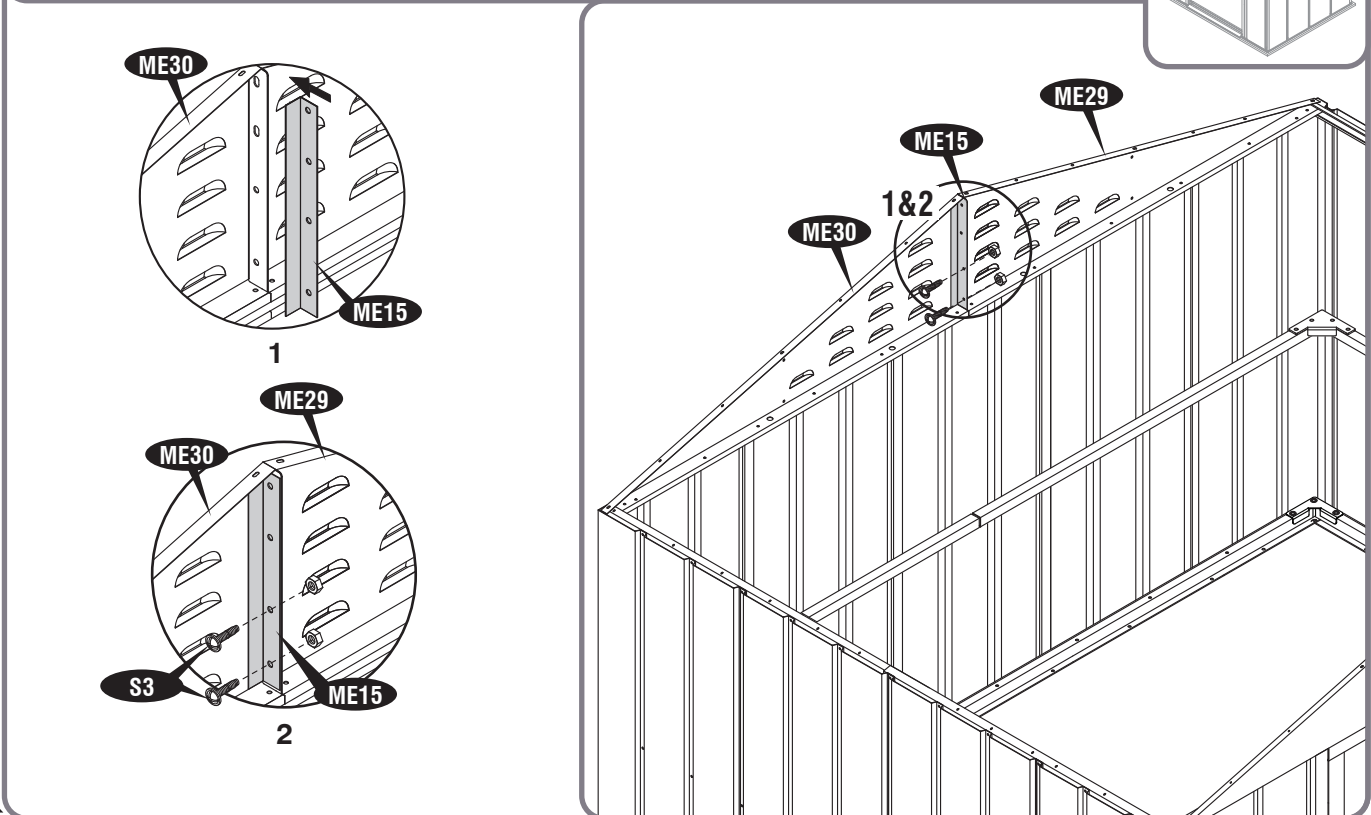
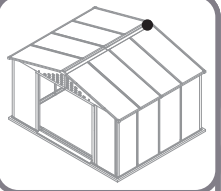

8

ME16 (x2)
ME17 (x2)

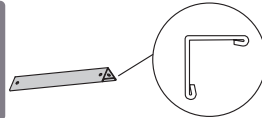
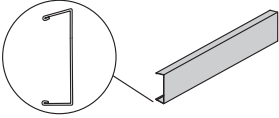

ME18 (x2)
ME19 (x2)



S3 (x16)

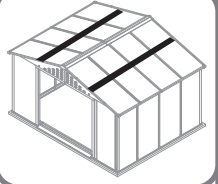

x2

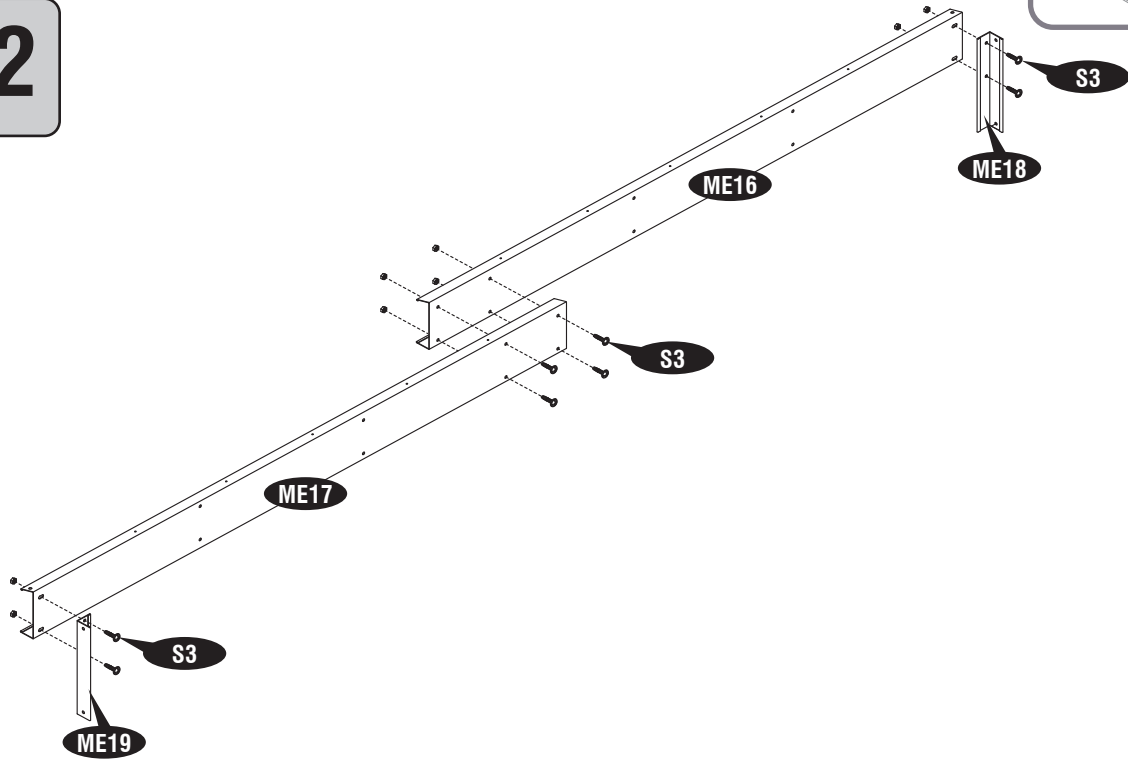

9

ME16 (x2)
ME17 (x2)

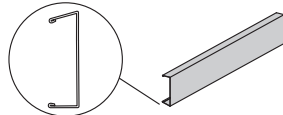

S1 (x8)



S3 (x4)

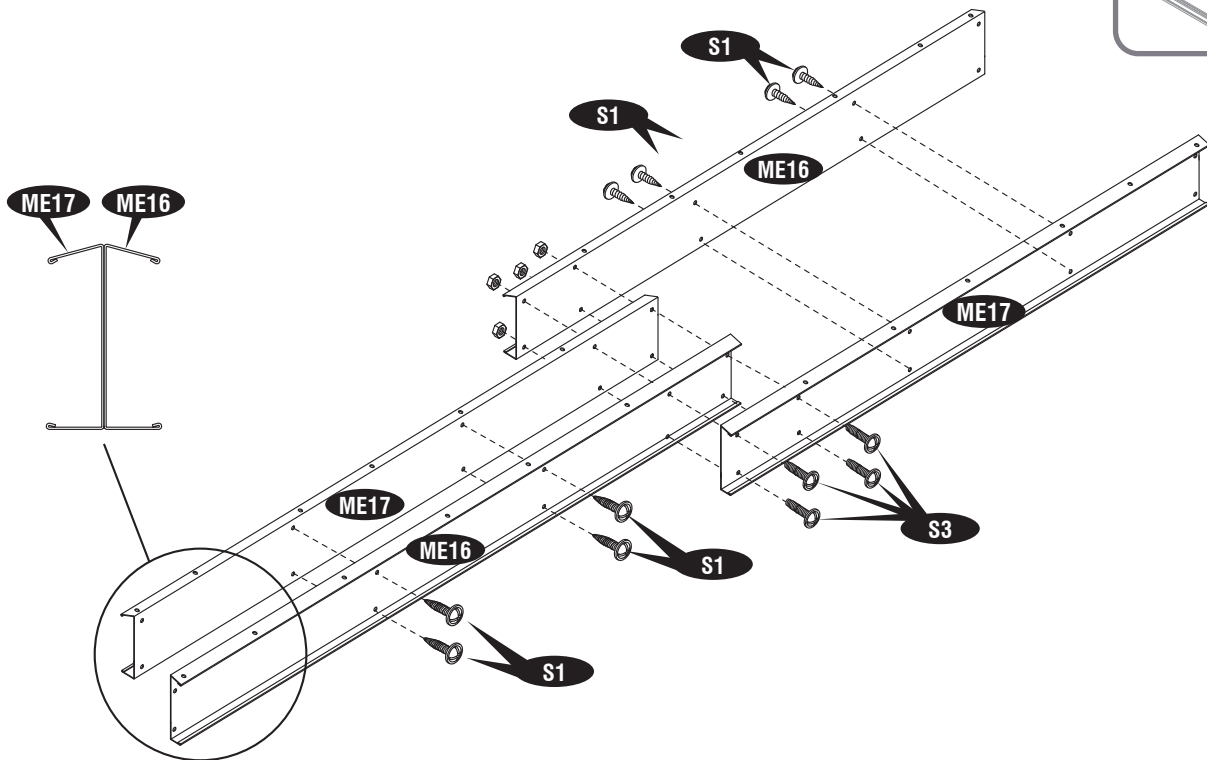
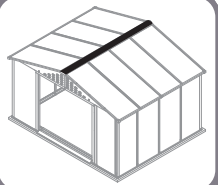

10



S3 (x8)



PW (x8)

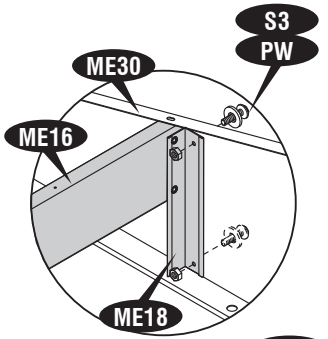
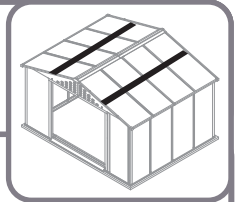

1

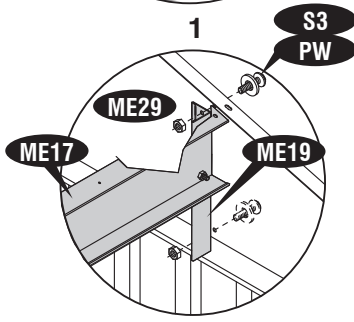

2

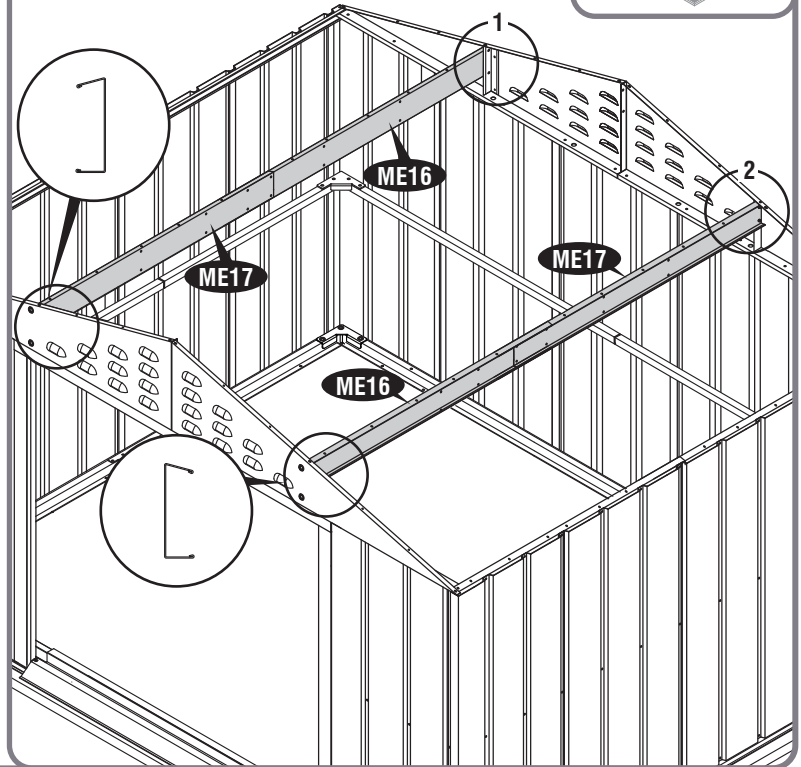

11



S3 (x4)

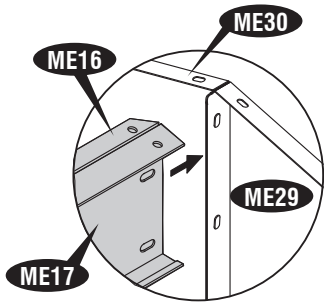
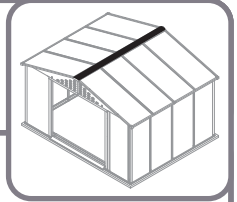

1

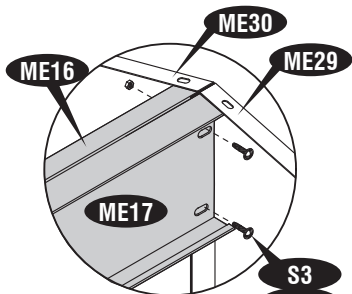

2

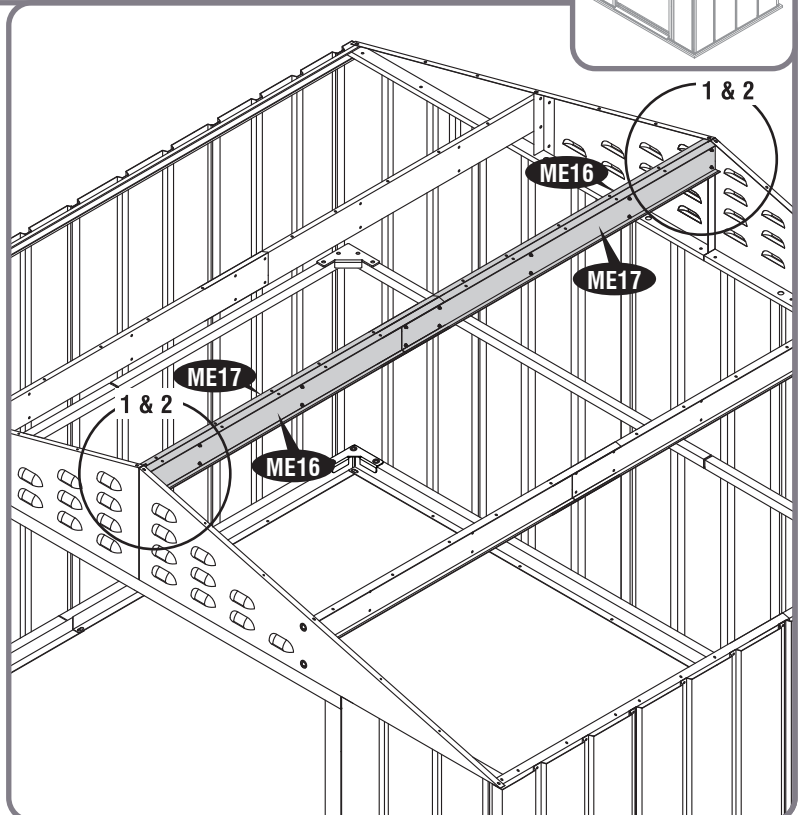

12

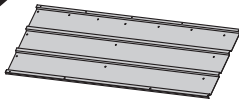

ME31 (x1)



S3 (x6)



PW (x6)

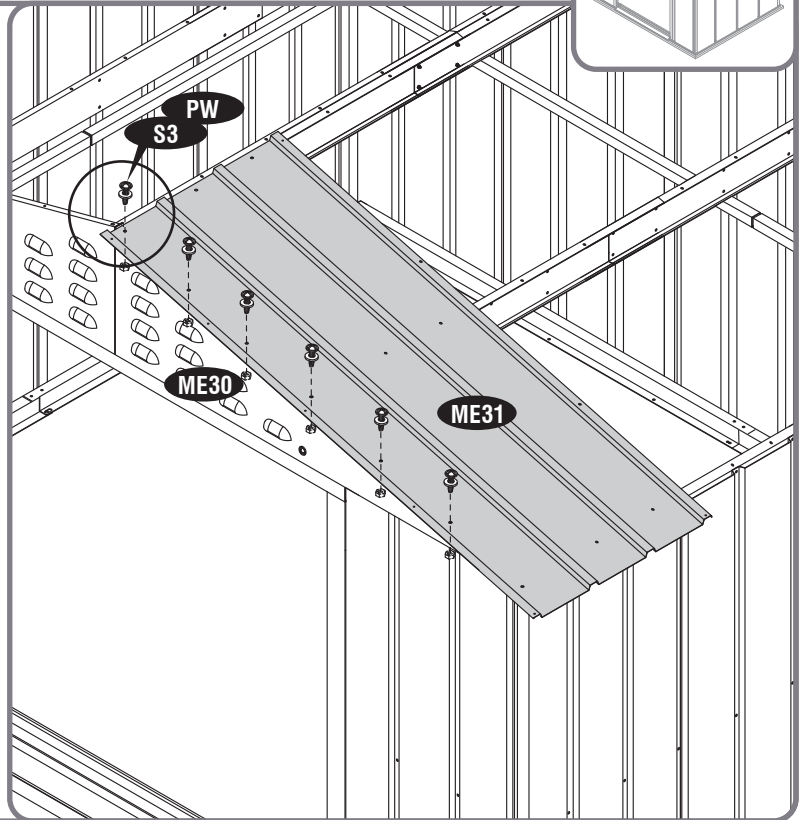
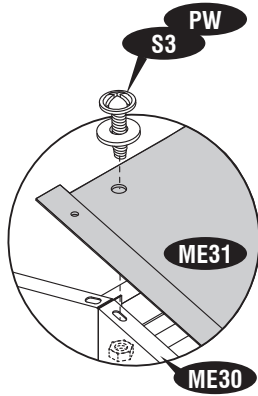
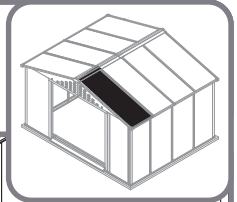

13



S1 (x7)



PW (x7)

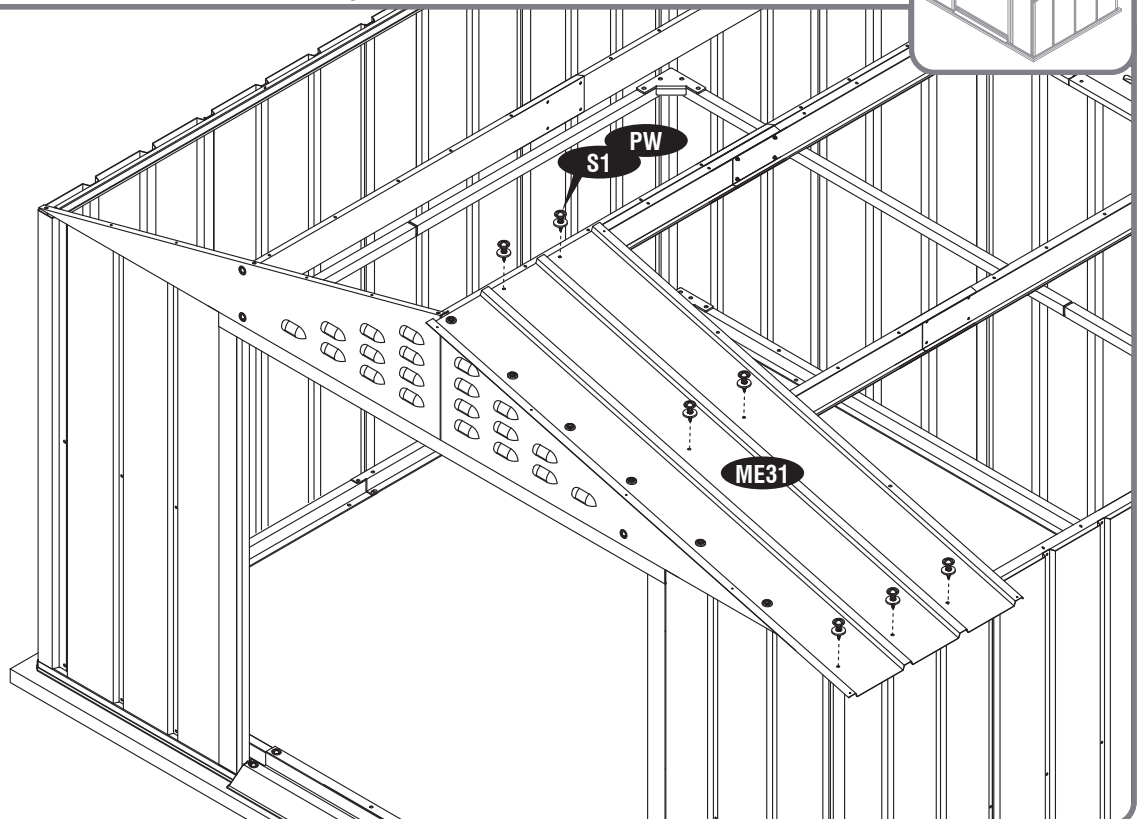
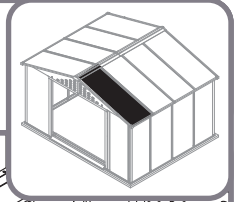

14

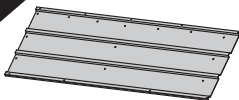

ME32 (x1)



S3 (x2)



S1 (x9)



PW (x11)

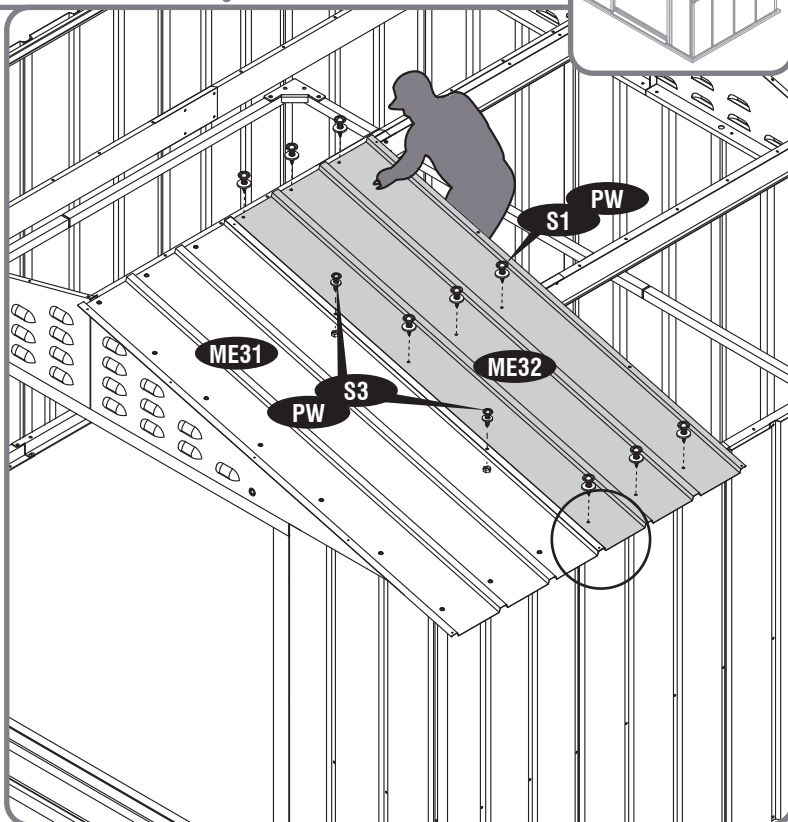
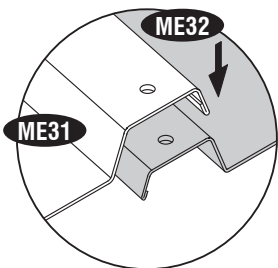
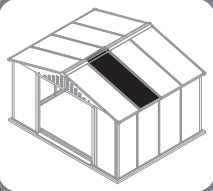

15

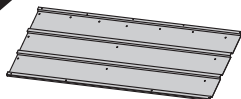

ME32 (x1)



S3 (x2)



S1 (x9)



PW (x11)

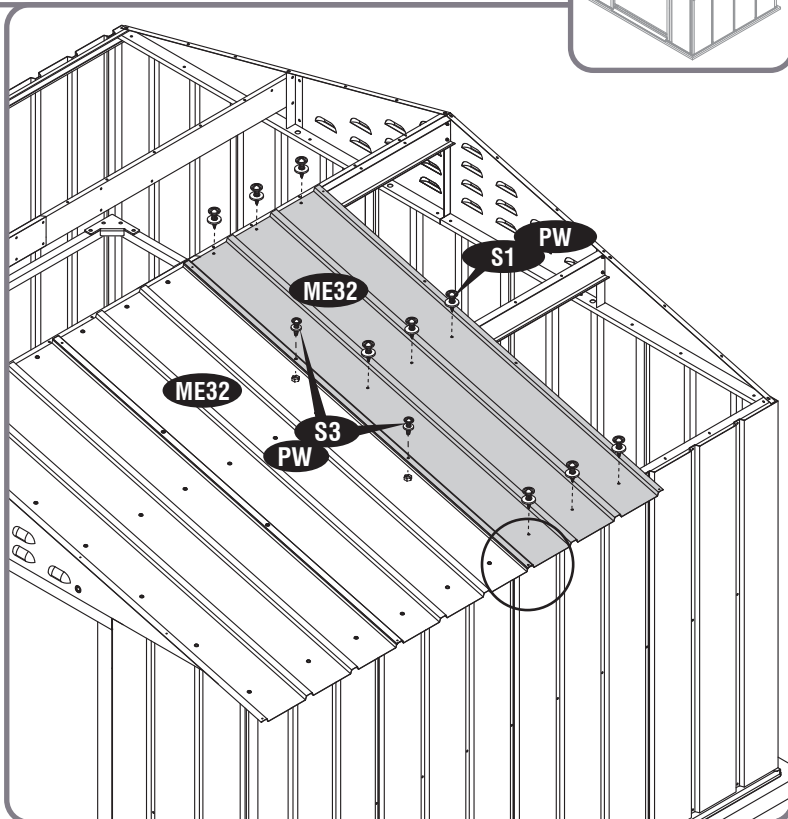
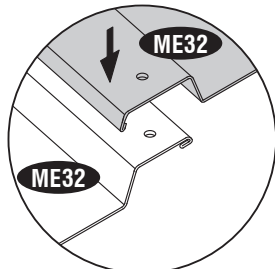
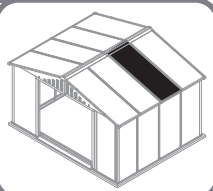

16

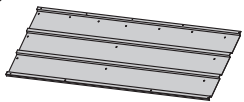

ME33 (x1)



S3 (x8)



S1 (x7)



PW (x15)

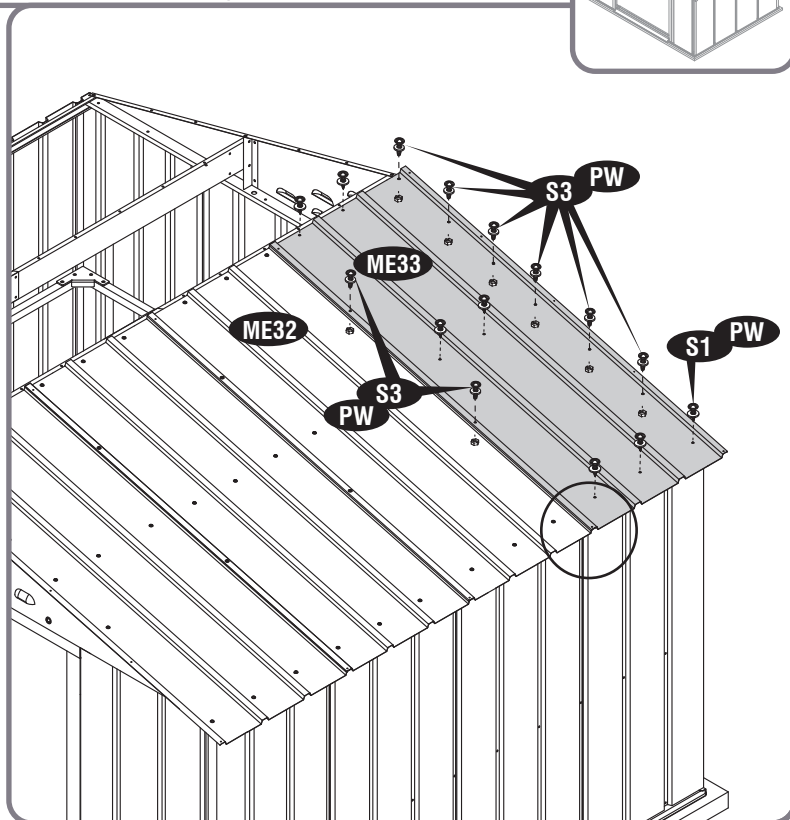
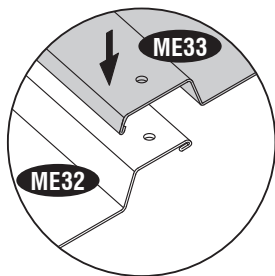
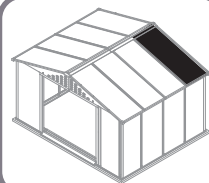

17

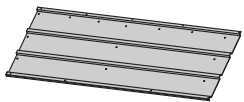

ME31 (x1)



S3 (x6)



S1 (x7)



PW (x13)

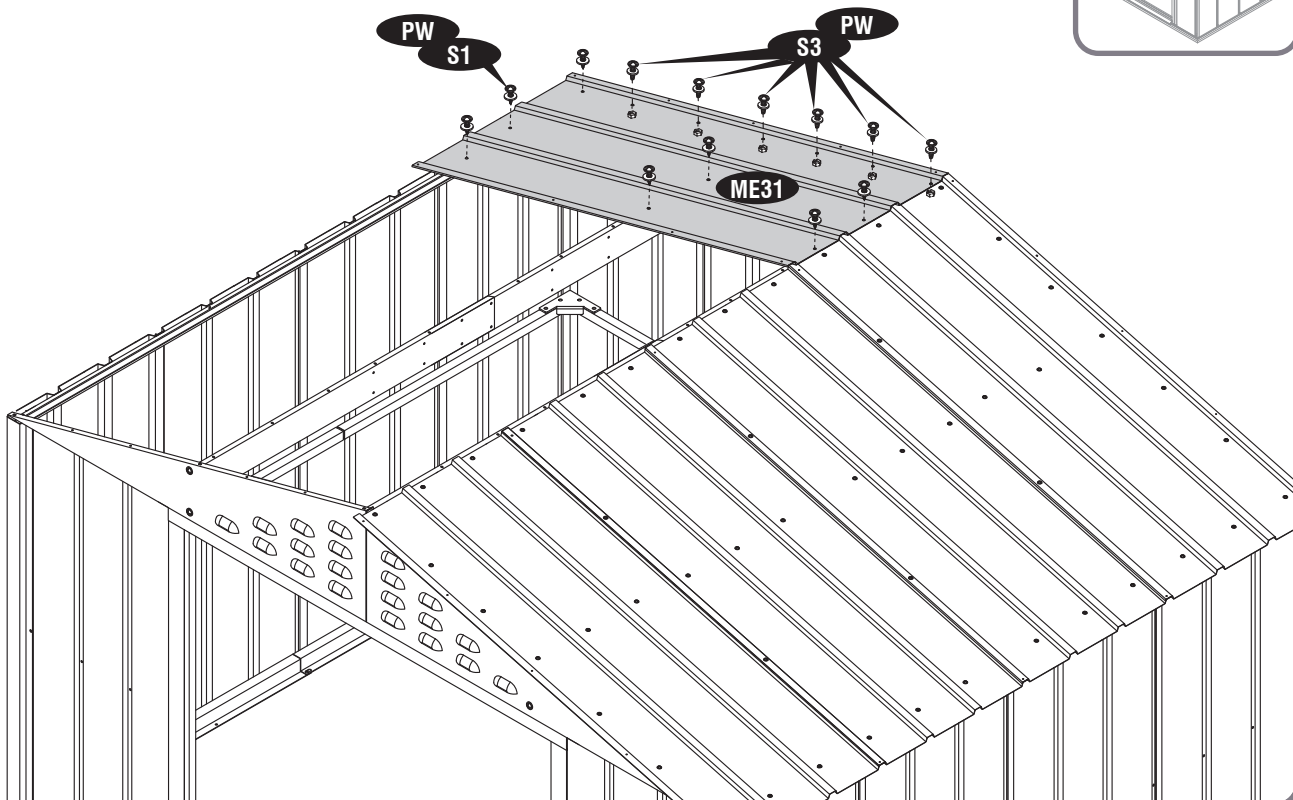
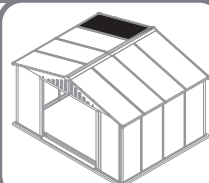

18



WST

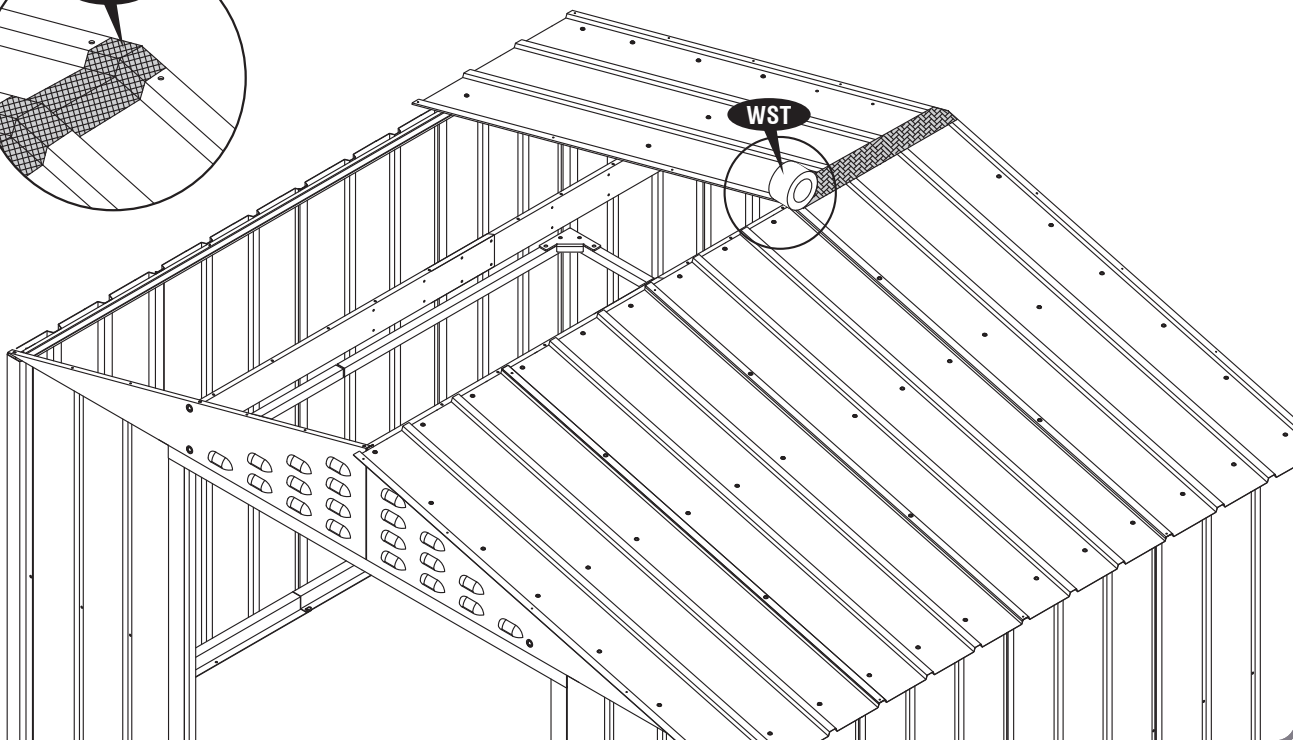
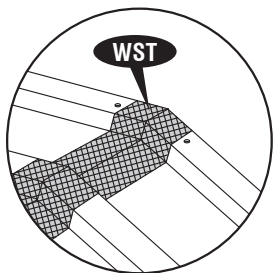
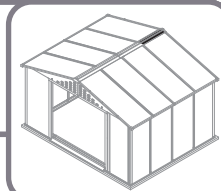

19

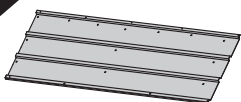

ME32 (x1)



S3 (x2)



S1 (x9)



PW (x11)

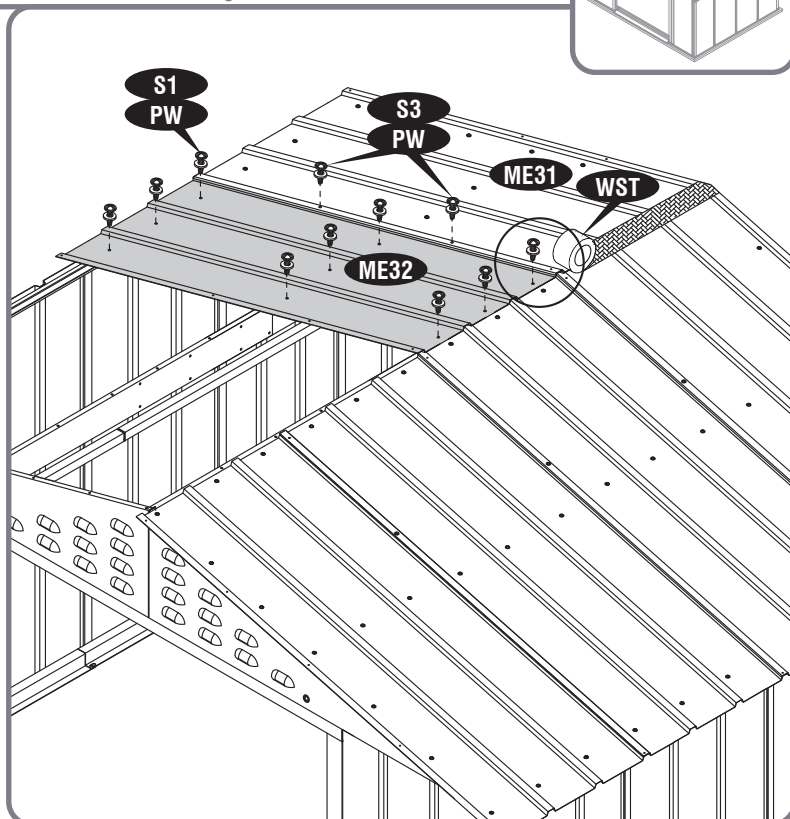
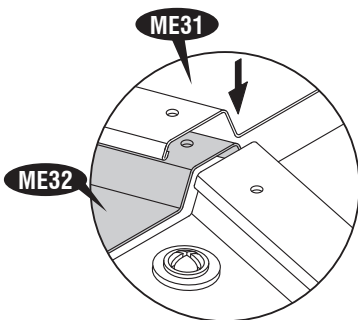
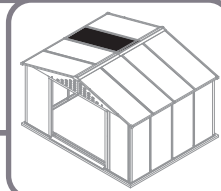

20

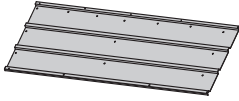

ME32 (x1)



S3 (x2)



S1 (x9)



PW (x11)

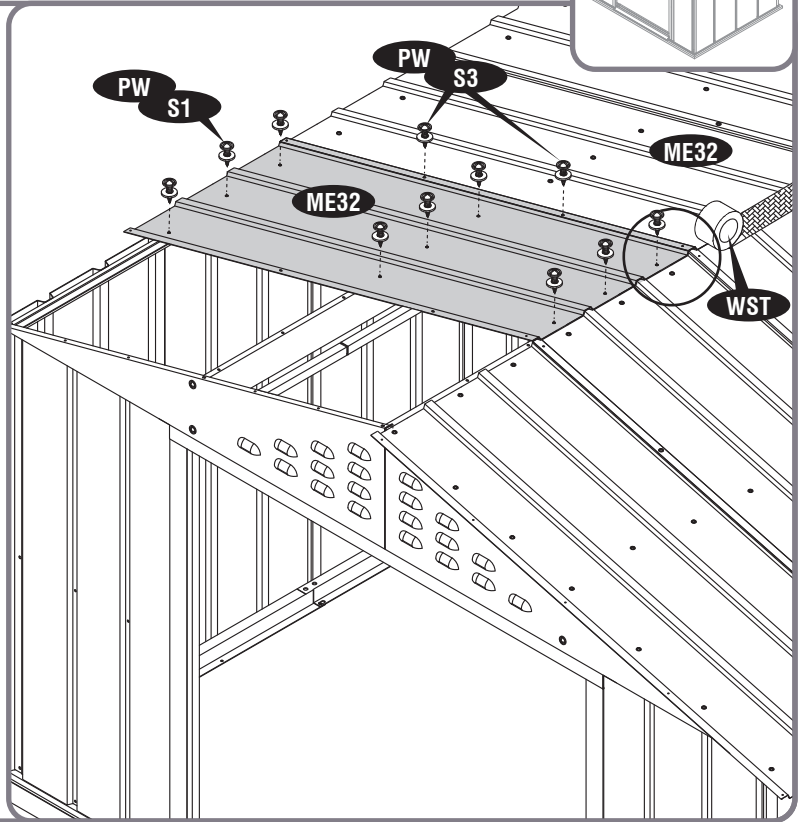
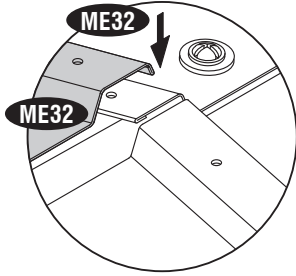
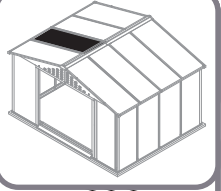

21

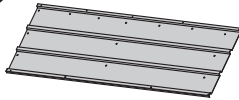

ME33 (x1)



S3 (x8)



S1 (x7)



PW (x15)

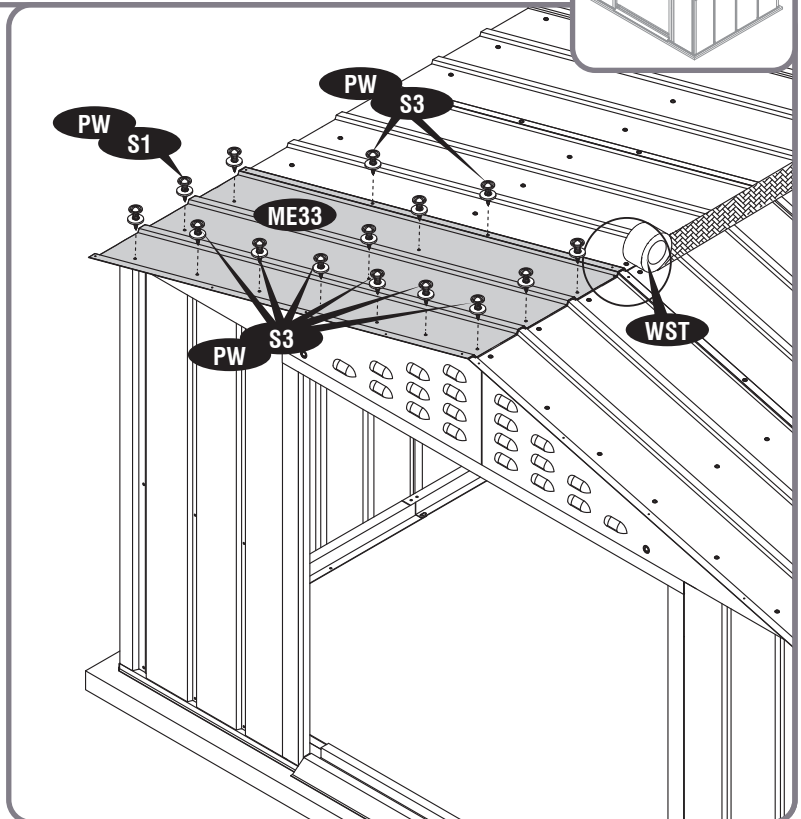
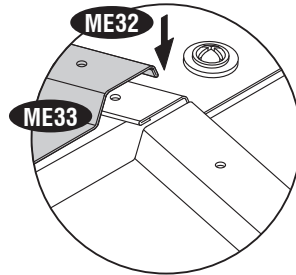
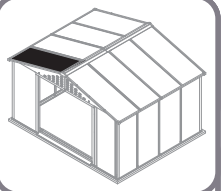

22

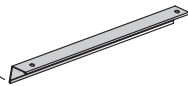

ME20 (x2)
ME21 (x2)



S1 (x12)



PW (x12)

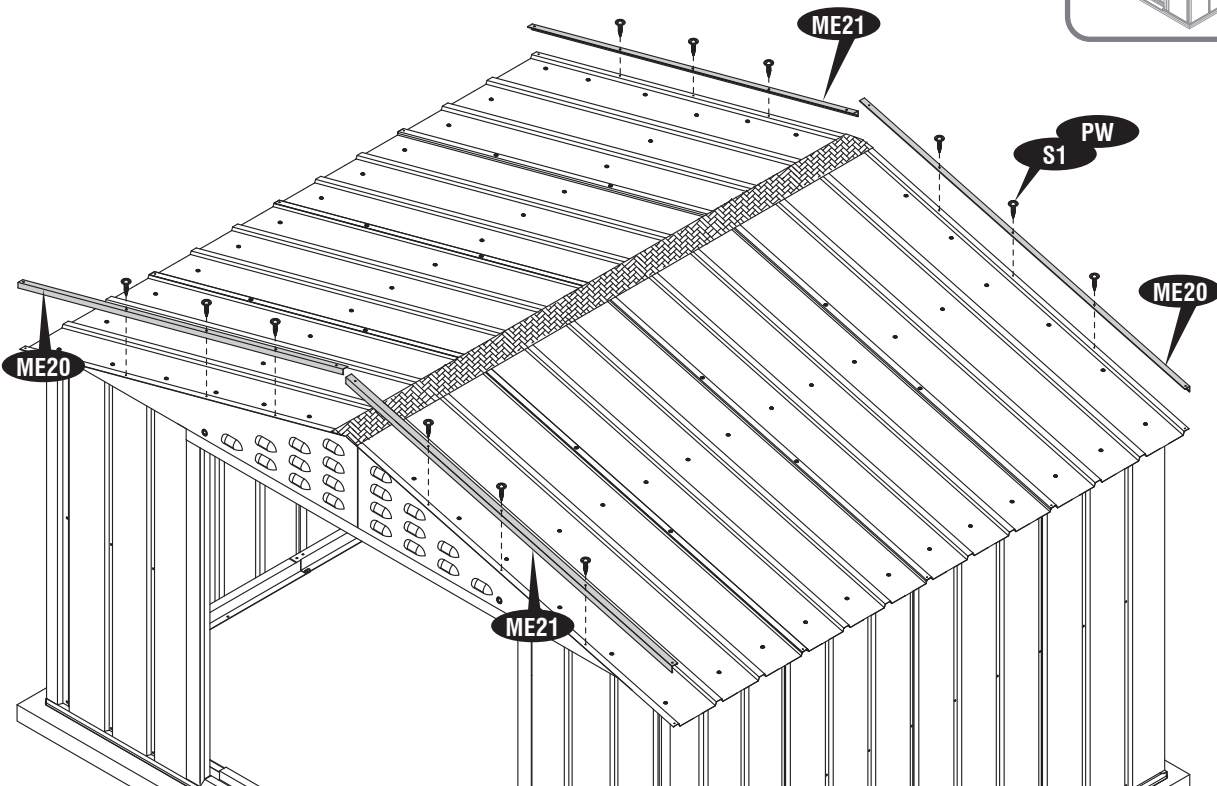

23

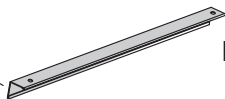

MA26 (x4)



S2 (x6)



PW (x6)

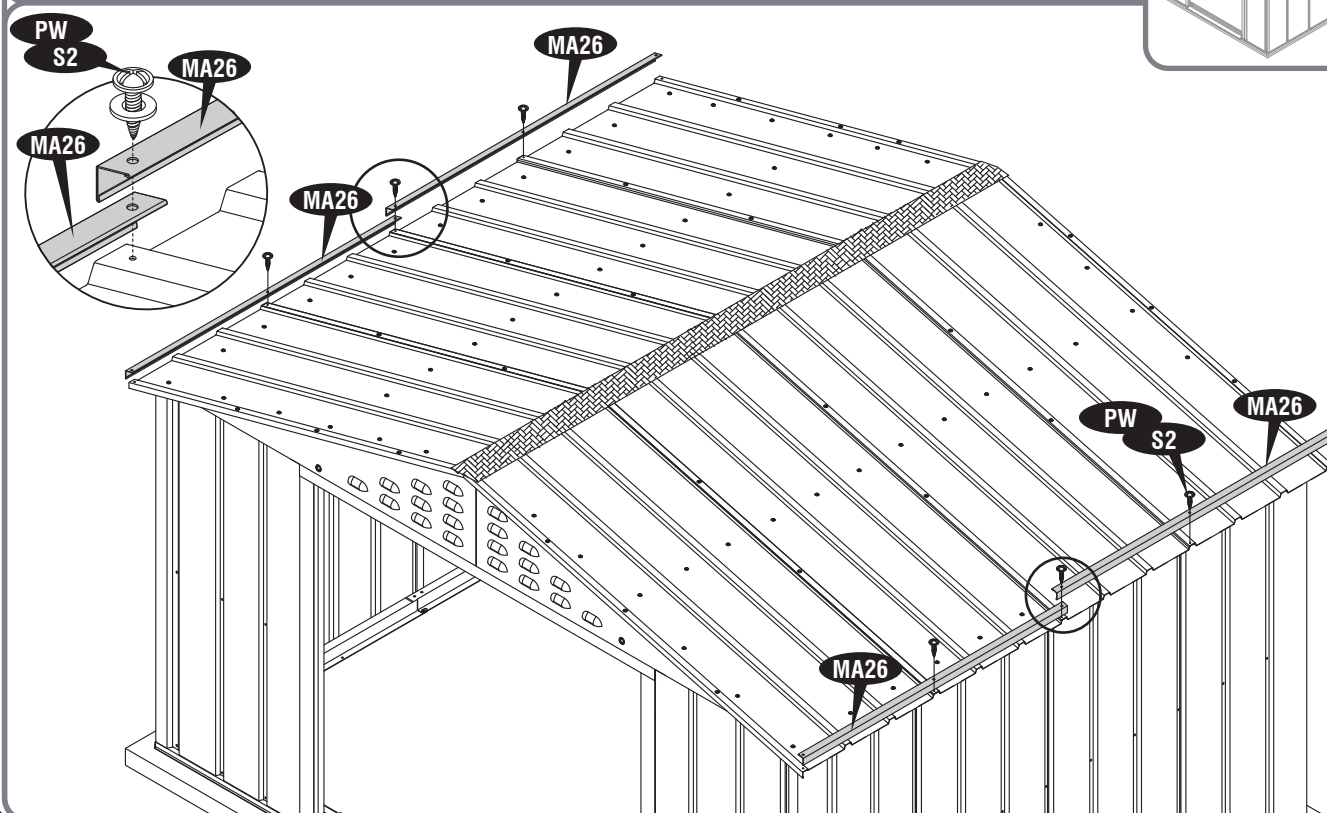
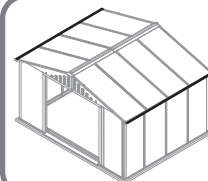

24

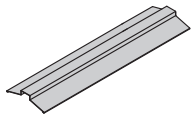

ME22 (x2)



S1 (x4)



PW (x4)

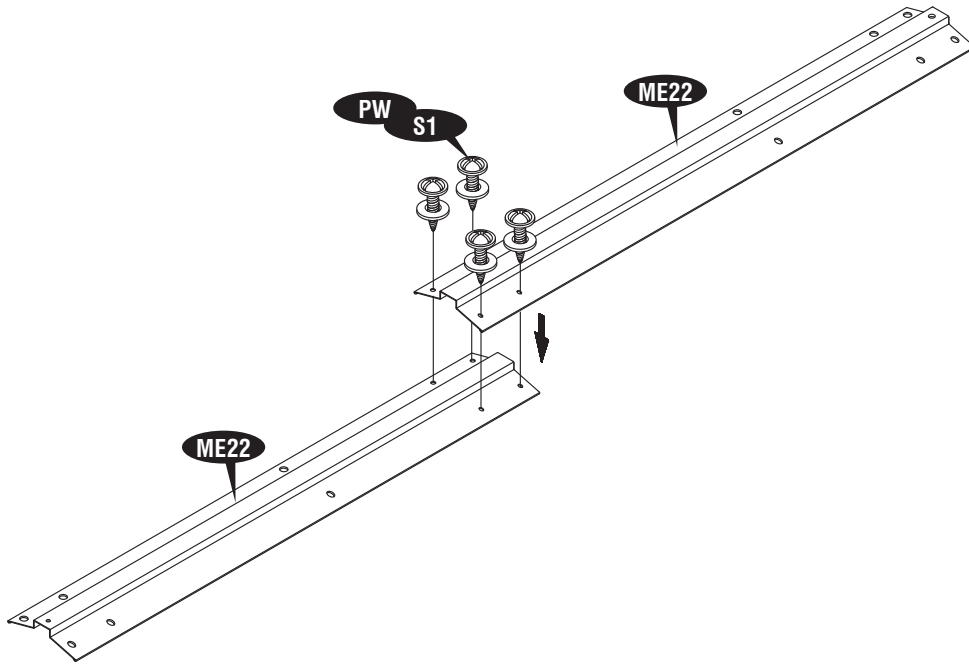
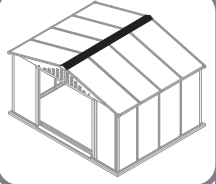

25



S2 (x8)



PW (x8)

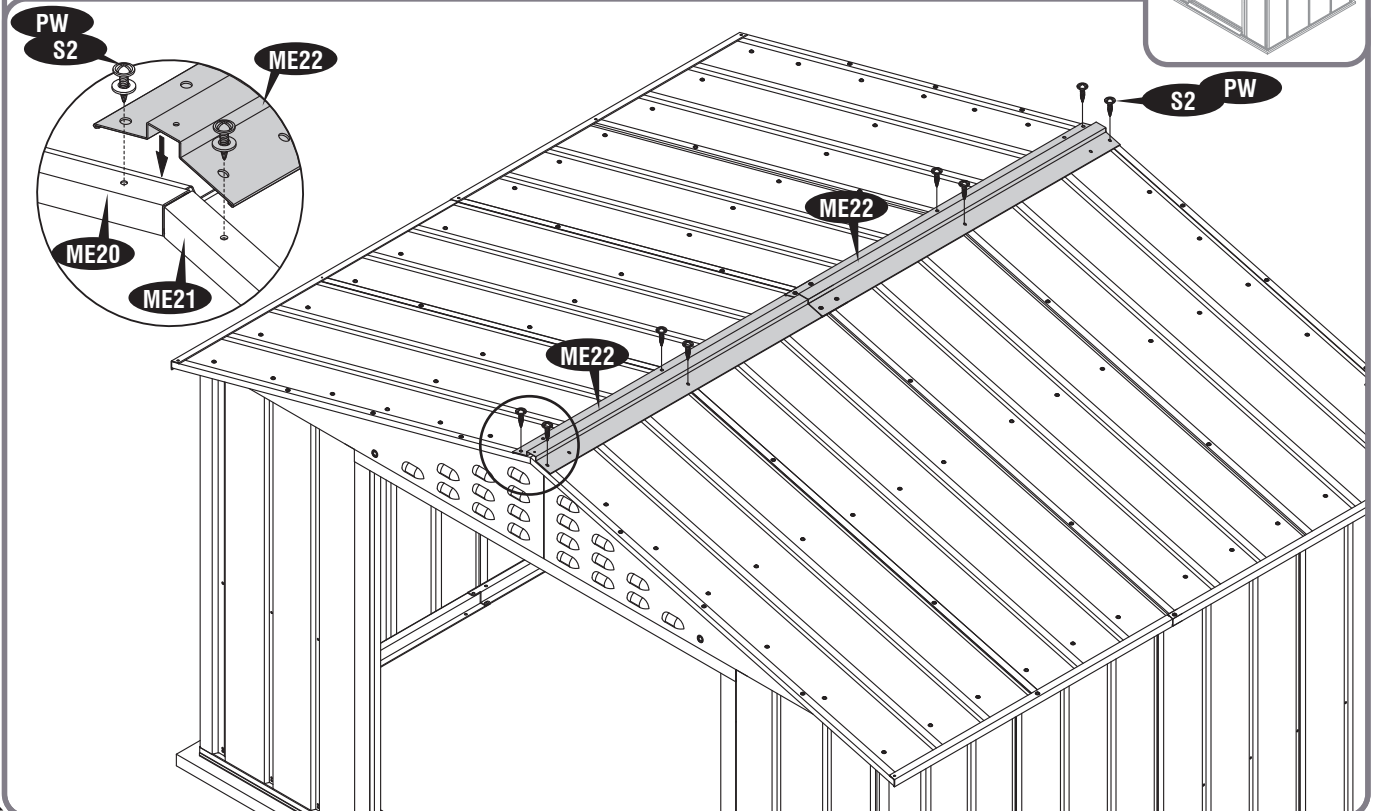
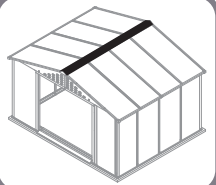

52

26

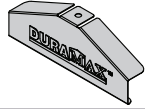

ME25 (x2)



S1 (x2)



PW (x2)

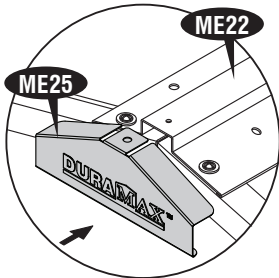
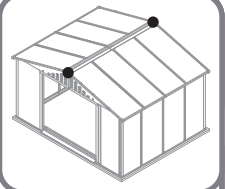

1

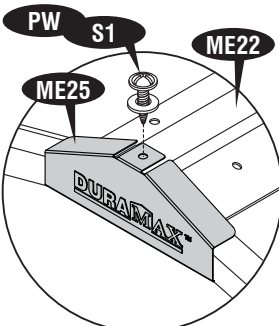

2

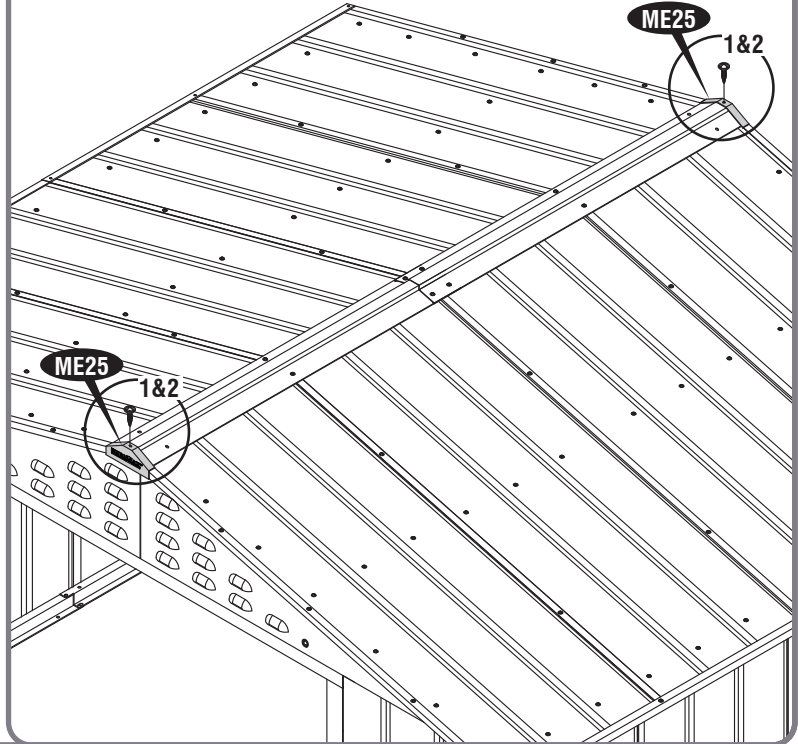

27

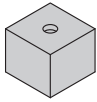

TC (x4)



S2 (x4)

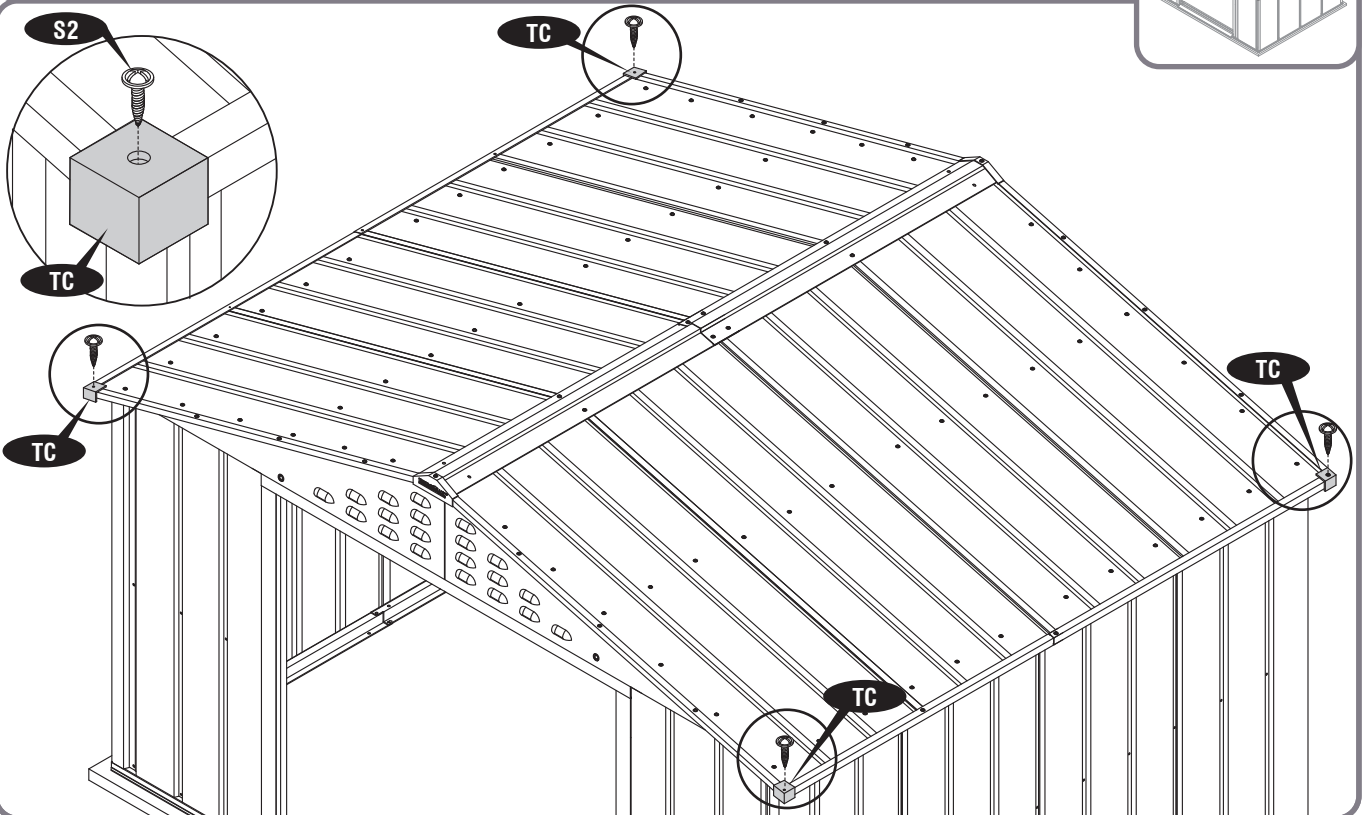
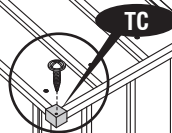
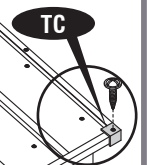
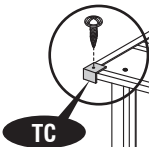
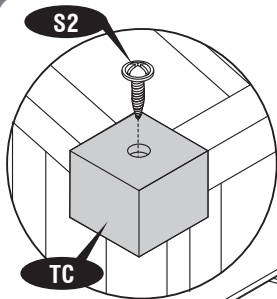
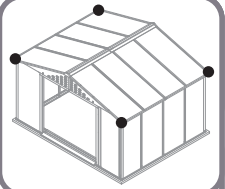

53

EN Assembly on Wooden platform

FR Ensemble sur plate-forme en bois

DE Montage auf Holzplattform

ES Asamblea en de madera plataforma

PT Montagem em plataforma de madeira

NL Montage op houten platform

CS Montáž na dřevěnou plošinu

SK Montáž na drevenej plošine

SL Montaža na leseni plošči

HR Montaža na drvenoj platformi

HU Összeszerelés faplatformon

SV Montering på träplattform

IT Montaggio su piattaforma in legno

PL Montaż na drewnianej platformie

RO Adunarea pe platforma de lemn

BG Сглобяване на дървена платформа

TR Ahşap platform üzerine montaj



28a

 S2 (x28)

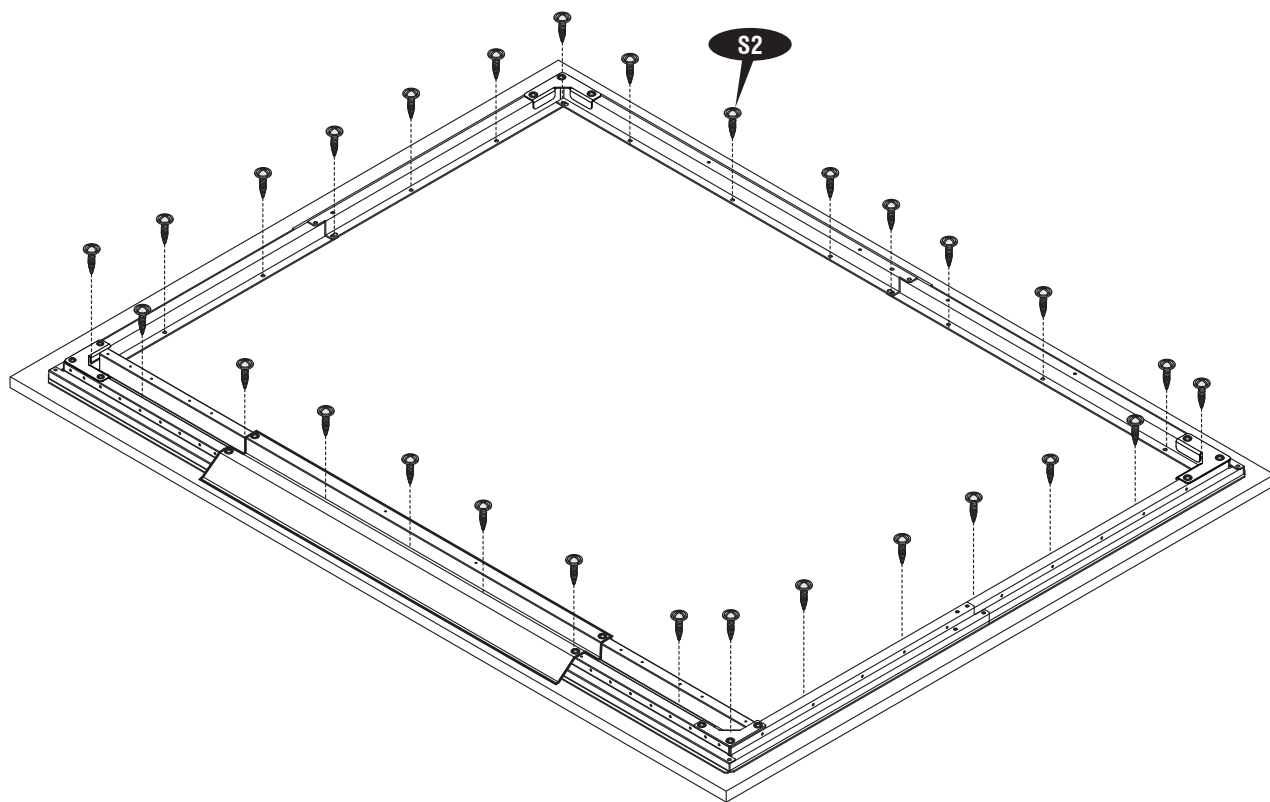

EN Assembly on Concrete Platform

CS Montáž na betonové plošině

IT Montaggio su piattaforma in calcestruzzo

FR Assemblage sur plate-forme en béton

SK Montáž na betónovú plošinu

PL Montaż na betonowej platformie

DE Montage auf Betonplattform

SL Montaža na betonsko ploščad

RO Adunarea pe platforma de beton

ES Montaje en plataforma de hormigón

HR Montaža na betonskoj platformi

BG Монтаж на бетонна платформа

PT Montagem em plataforma de concreto

HU Szerelés beton felületen

TR Beton platform üzerine montaj

NL Montage op betonplatform

SV Montering på betongplattform



28b



F1 (x28)



S8 (x28)

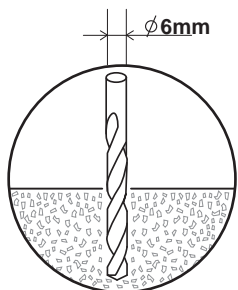

1

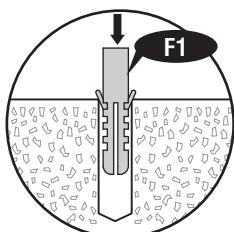

2

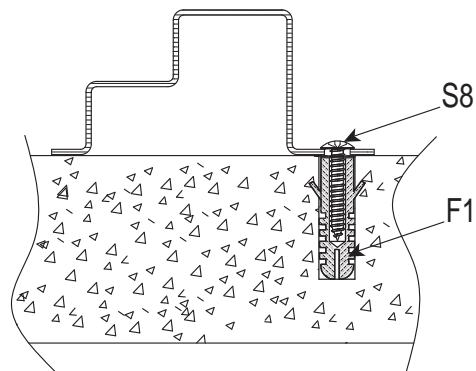

3

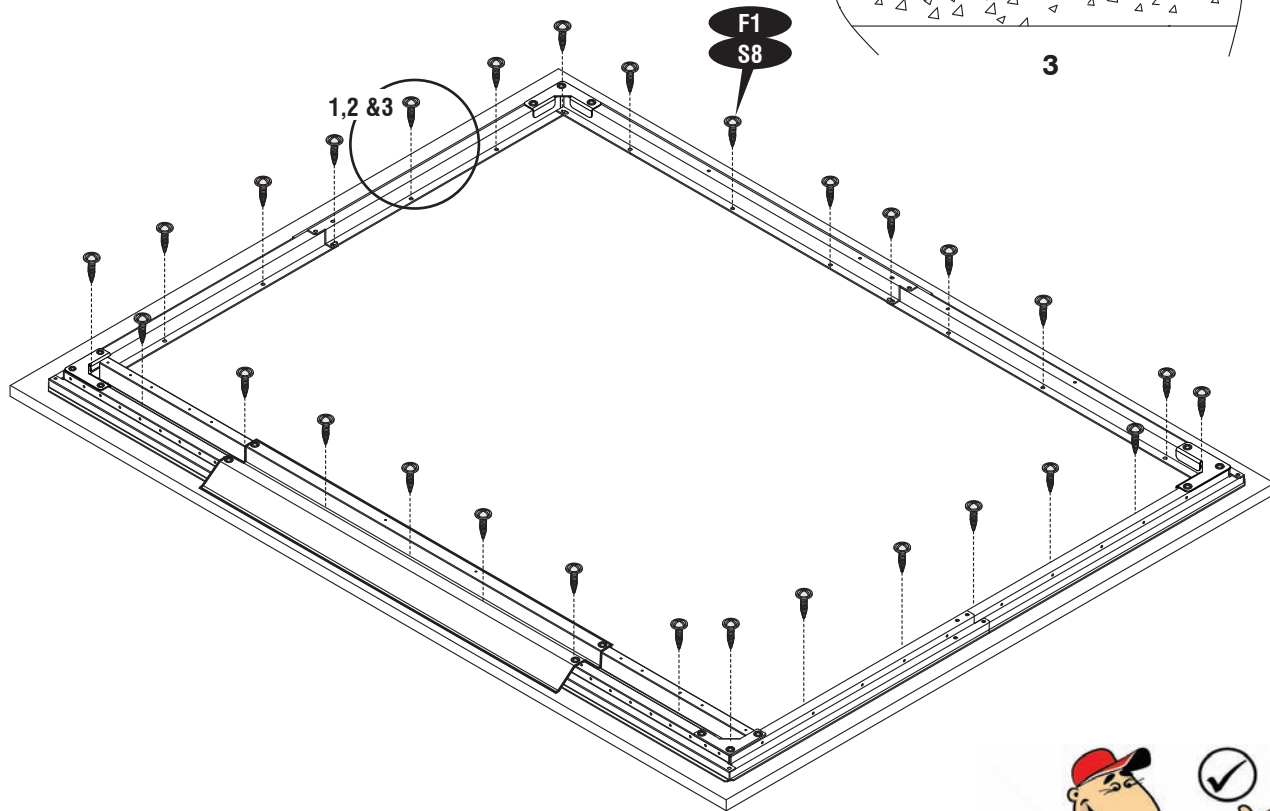



4

EN Door

FR Porte

DE Die Tür

ES La puerta

PT Porta

NL De deur

CS Dveře

SK Dvere

SL Vrata

HR Vrata

HU Ajtó

SV Dörr

IT Porta

PL Drzwi

RO Ușa

BG Врата

TR Kapı

EN Parts needed

FR Pièces nécessaires

DE Benötigte Teile

ES Las partes necesarias

PT Peças Necessárias

NL Onderdelen nodig

CS Potřebné součásti

SK Potrebne časti

SL Dele, ki jih boste potrebovali

HR Dijelovi potreban

HU Szükséges részek

SV Delar som behövs

IT Parti occorrenti

PL Niezbędne elementy

RO Elementele componente necesare

BG Необходими части

TR Gerekli parçalar

ME23	1
ME24	1
MA30	1
MA31	1
MA32	2
ME34	1
ME35	1

ME36	1
ME37	1
MA48	8
PW	32
S1	54
S3	4

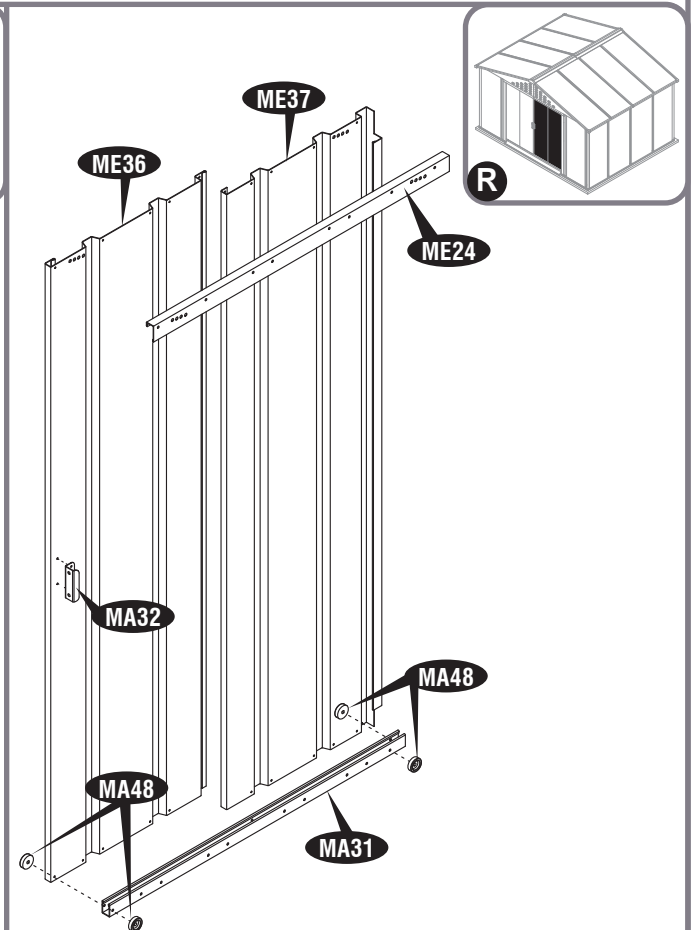
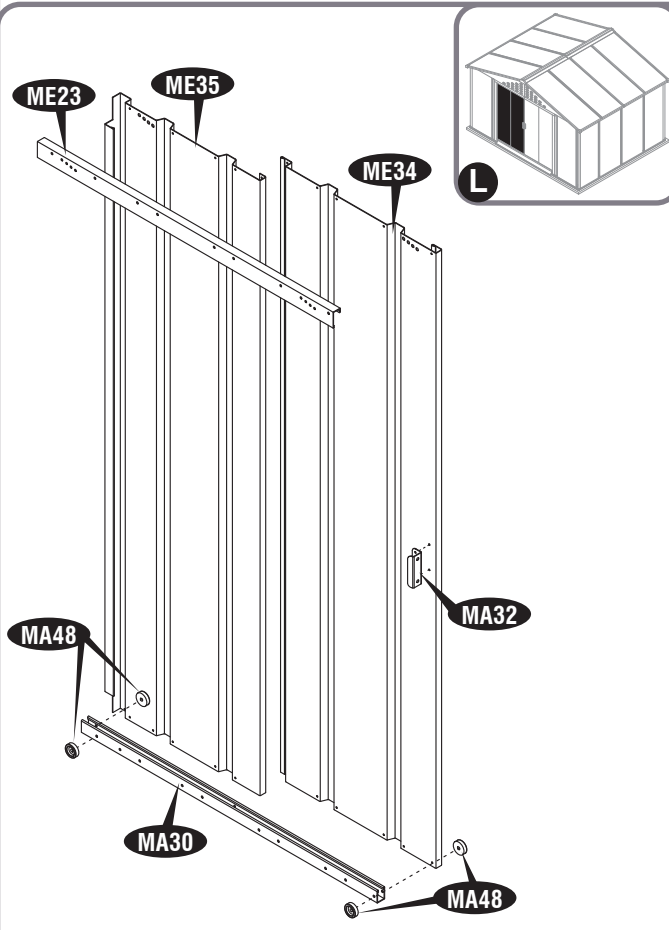

1

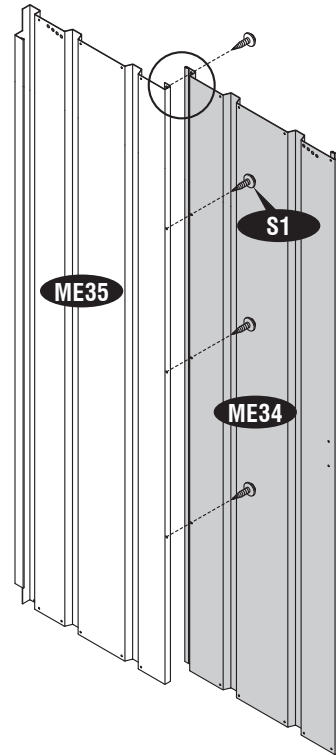
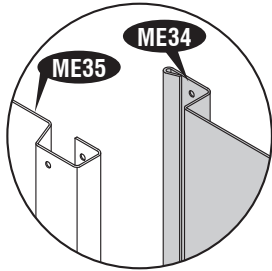
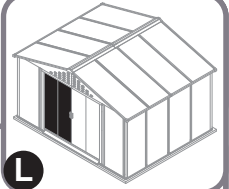
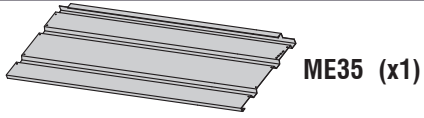
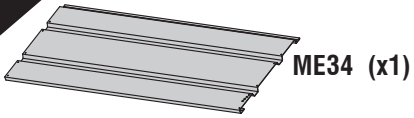

2

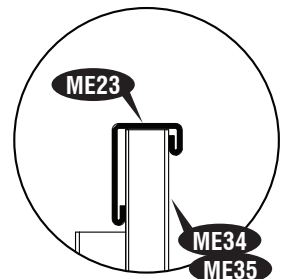
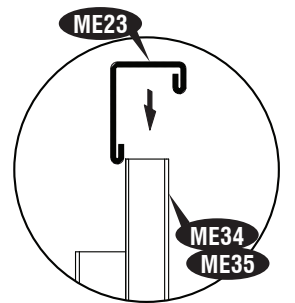
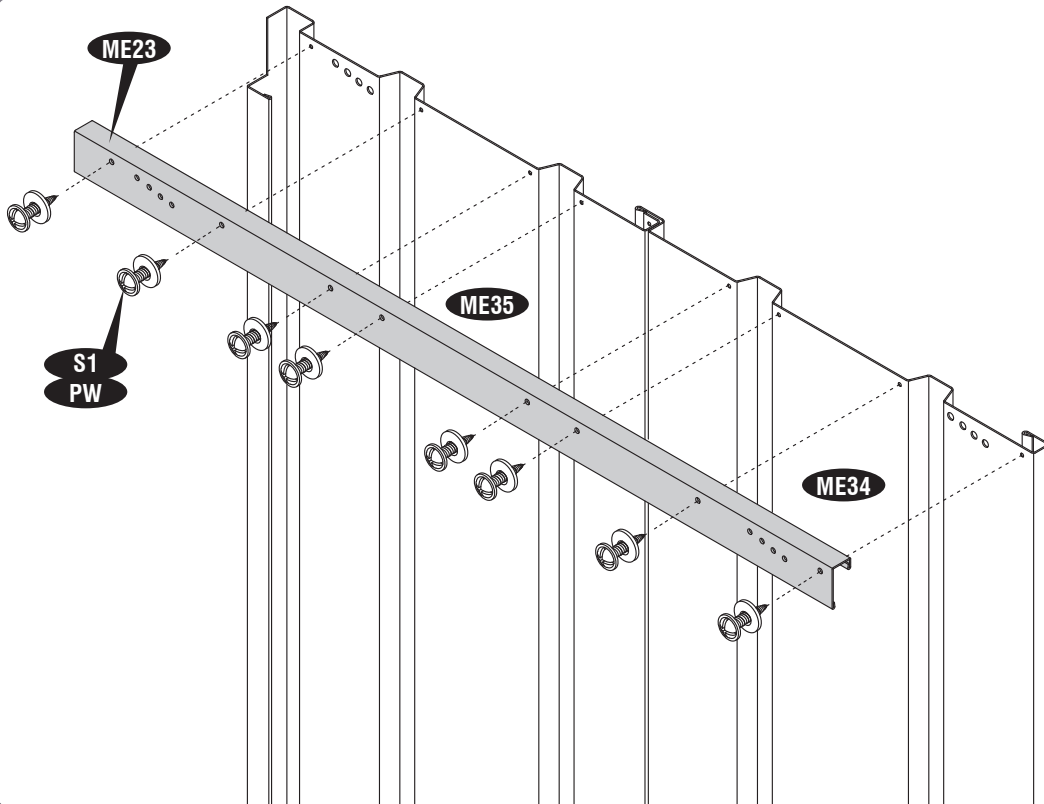
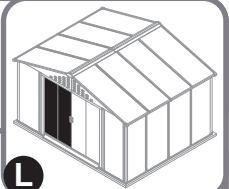
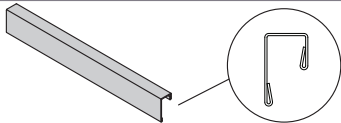

3

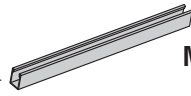
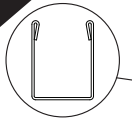

MA30 (x1)



MA48 (x4)



S1 (x13)



PW (x8)

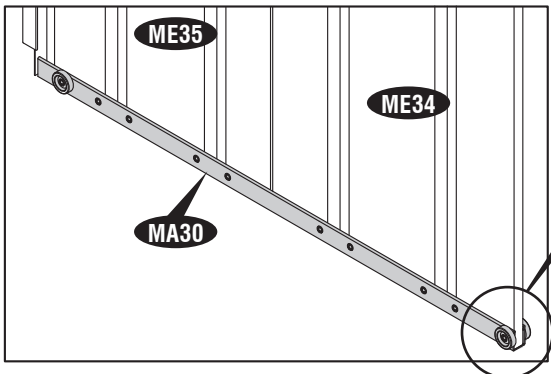
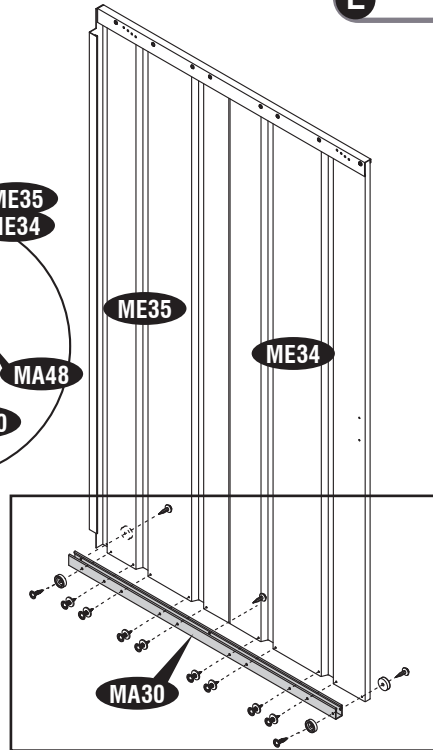
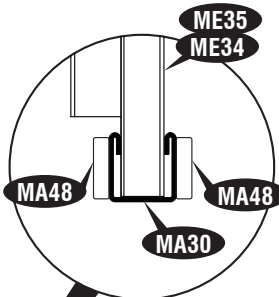
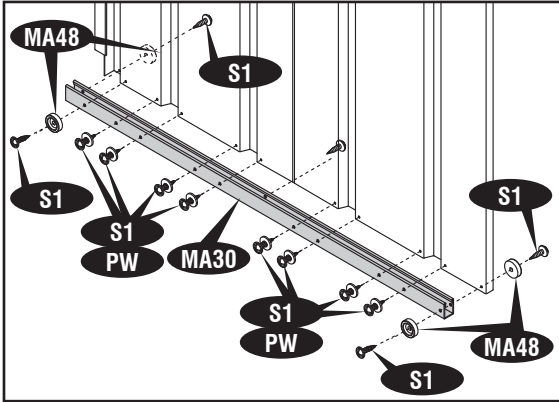
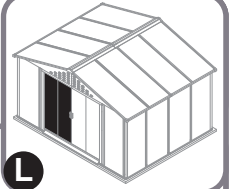

4

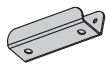

MA32 (x1)



S3 (x2)

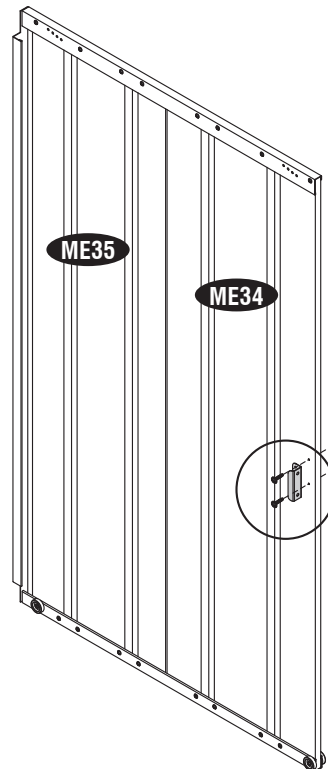
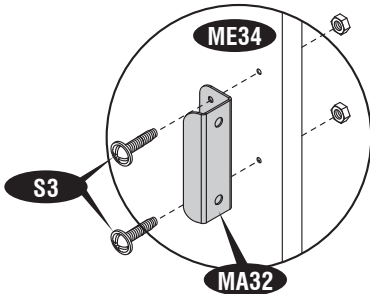
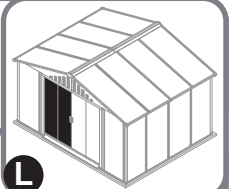

5

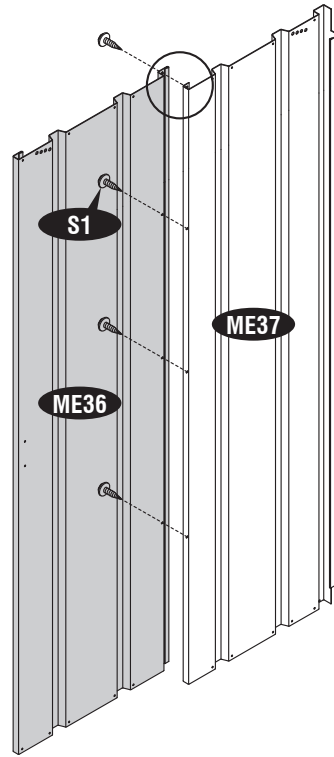
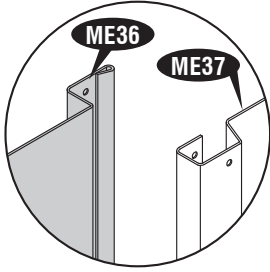
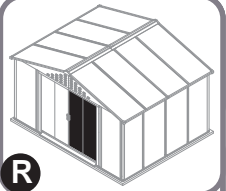
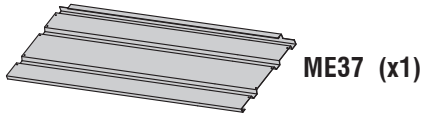
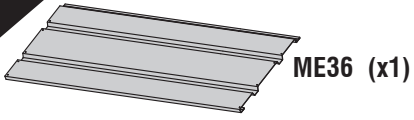

6

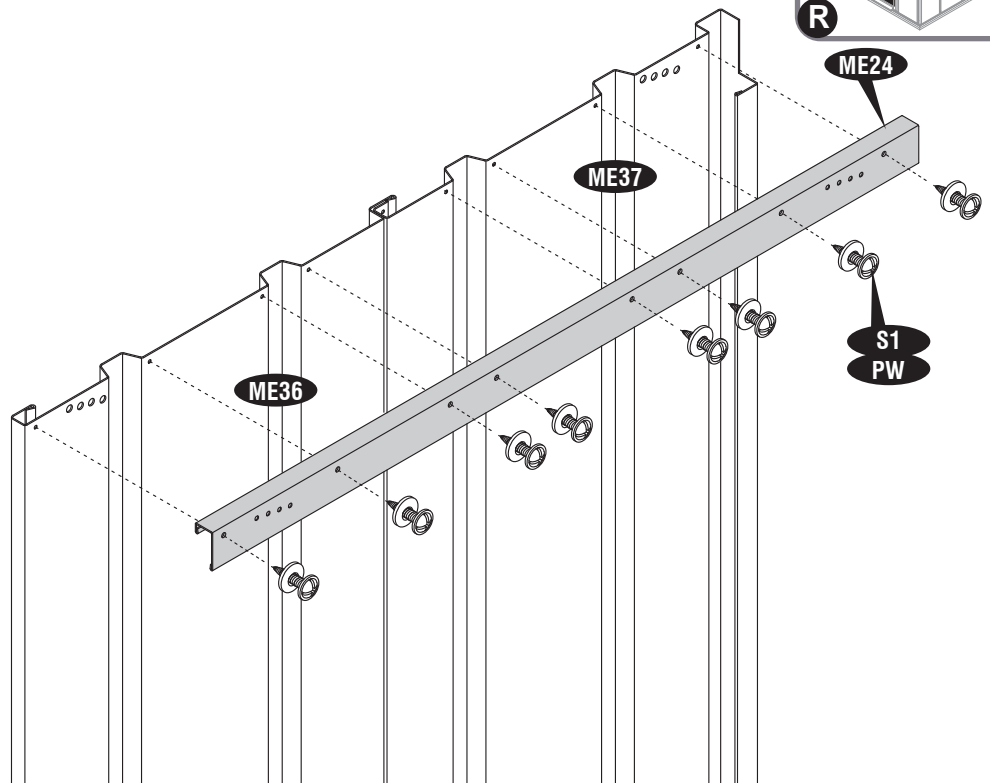
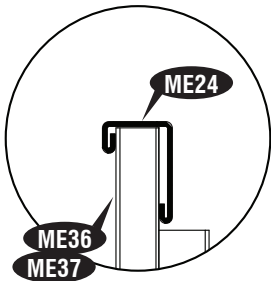
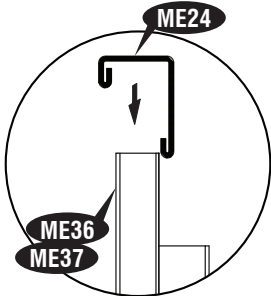
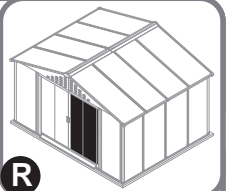
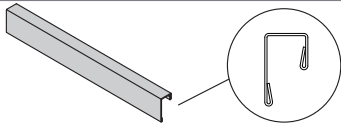

7

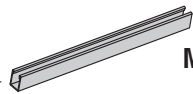

MA31 (x1)



MA48 (x4)



S1 (x13)



PW (x8)

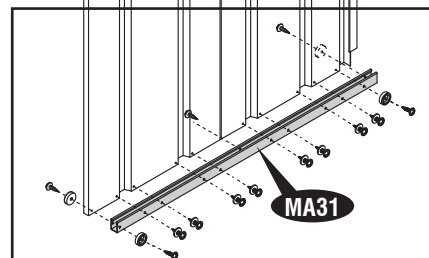
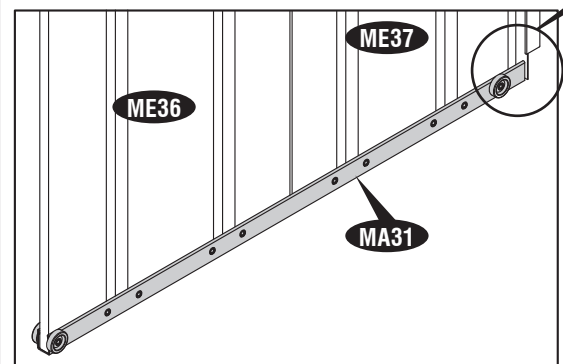
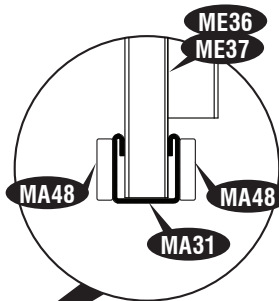
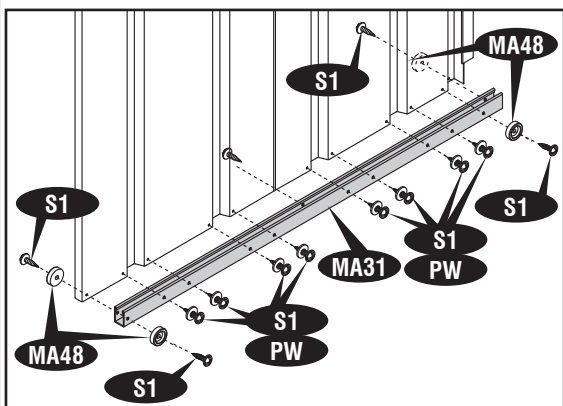
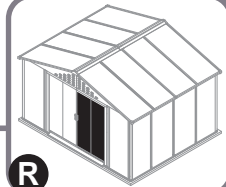

8

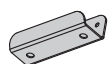

MA32 (x1)



S3 (x2)

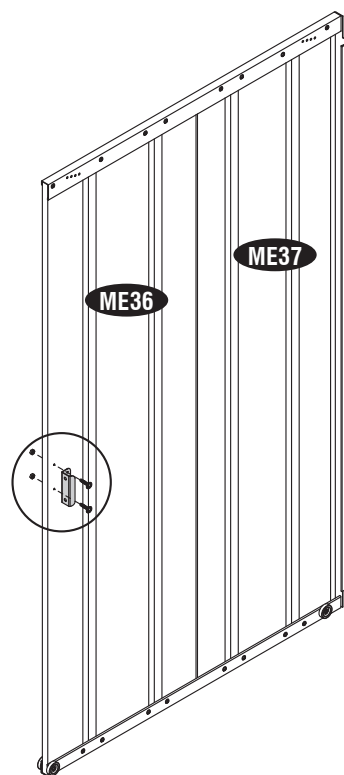
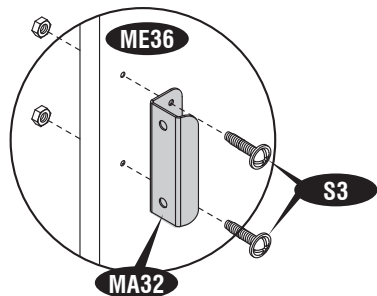

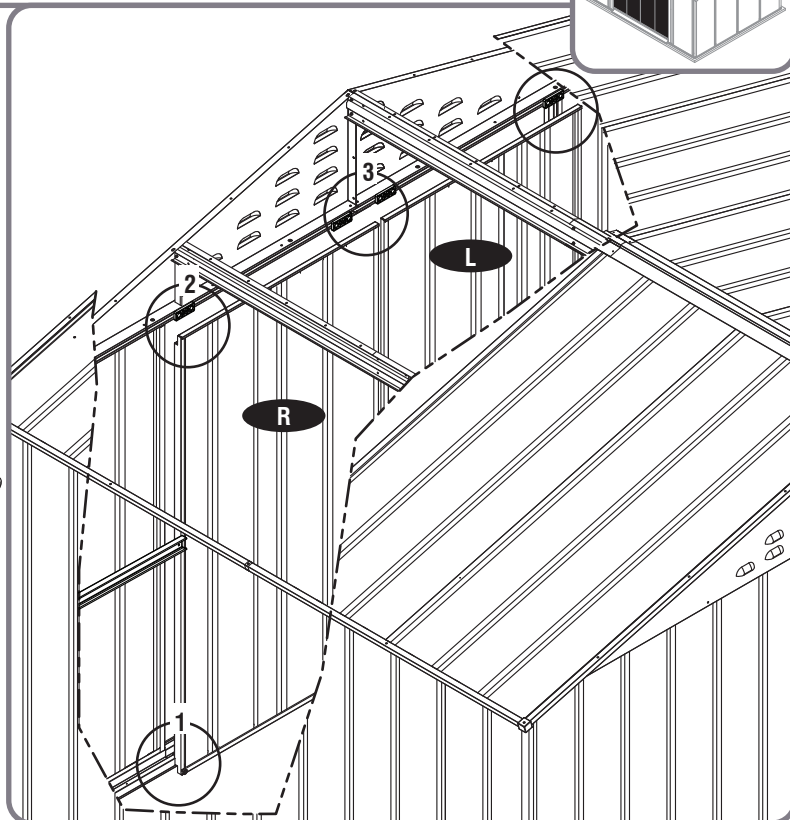
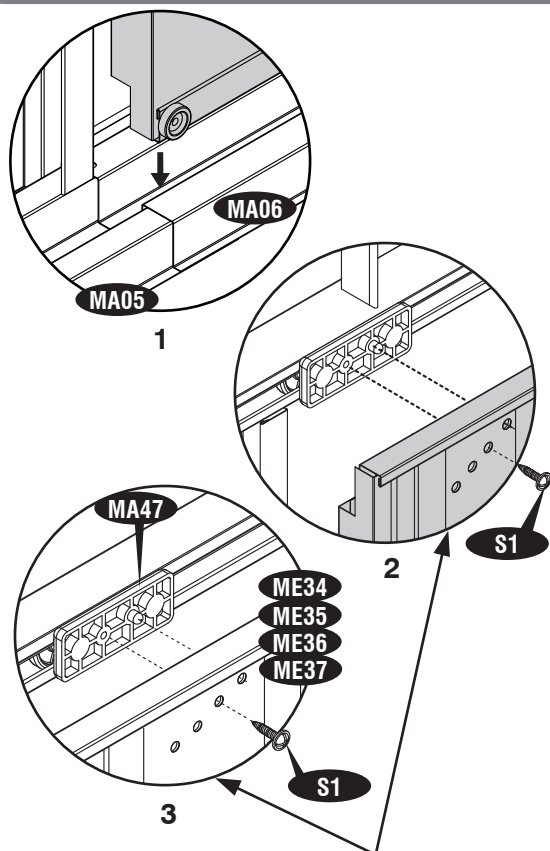
 S1 (x4)

EN To get proper alignment of the door realign the holes with door panel. See fig.

FR Pour obtenir un bon alignement de la porte, réaligner les trous avec la paroi de porte. Voir fig.

DE Um die Tür richtig anzupassen, richten Sie die Löcher noch einmal mit der Türplatte aus. Siehe Abb.

ES Para obtener la alineación apropiada de la puerta realinea los hoyos con entrepaño de puerta. Vea fig.

PT Para obter um alinhamento adequado da porta realinhe os buracos com o painel da porta. Ver fig.

NL Zorg ervoor dat de gaten goed aansluiten op die in het deurpaneel. Zie figuur.

CS Aby dveře byly správně nastavené, narovnejte díry v dveřním panelu. Dle obrázku.

SK Aby ste dosiahli správne vyrovnanie dverí, opäť vyrovnajzte otvory podľa dverí. Pozri obr.

SL Ponovno poravnajte luknje vratne prevleke, da je zagotovljena pravilna poravnava. Glejte sliko..

HR Da biste dobili odgovarajuće poravnanje vrata pregrupirati rupe s vratom panelom. Vidjetite sliku.

HU Az ajtó megfelelő illeszkedése érdekében állítsa be a lyukakat az ajtópanelhez. Lásd az ábrát.

SV För att åstadkomma rätt justering av dörren, placera hålen i linje med dörrpanelen. Se figur.

IT Per avere un allineamento corretto della porta, allinea i buchi col pannello della porta, Vedi la figura.

PL W celu właściwego zamocowania drzwi ponownie dopasuj otwory do panelu drzwiowego. Zob. rys.

RO Pentru a se realiza centrarea corespunzătoare a ușii, realiniați găurile cu cadrul ușii. A se vedea fig..

BG За да получите правилно подравняване на вратата, изравнете наново отворите с плота на вратата. Виж фигурата.

TR Kapının düzgün hizalanması için delikleri kapı paneline düzgünce tekrar hizalayınız. Resme Bakınız.



- EN** Fix the plastic screw cover (PC) to the screws and bolts edge from inside to prevent injury.
- FR** Fixer le couvercle à vis en plastique (PC) à la pointe de vis et de boulons à l'intérieur pour prévenir les accidents.
- DE** Befestigen Sie die Kunststoffschraubenbedeckung (PC) an das Ende der Schrauben und Bolzen von innen, um Verletzungen zu verhindern.
- ES** Fije la cubierta (PC) plástica del tornillo a la orilla de tornillos y cerrojos de dentro de prevenir la herida.
- PT** Fixar as coberturas plásticas (PC) em todos os parafusos e porcas para prevenir lesões.
- NL** Op de plastic schroefdoppen (PC) op de schroeven en bouten om verwondingen te vermijden.
- CS** Nasadte plastové krytí šroubu(PC), aby zabránit případným zraněním.
- SK** Položte umelé kryty na skrutky (PC) a šraubky z vnútornej strany, aby ste predišli úrazu.
- SL** Pritrdite plastične pokrove za vijake (PC) na vijake in robove sornikov z notranje strani, da preprečite telesne poškodbe.
- HR** Popravite plastični poklopac vijak (PC) do vijaka i matica rub od unutra za sprječio ozljede..
- HU** Helyezze fel a (PC) műanyag csavarfedeleket a csavarokra belülről, a sérülések elkerülése érdekében.
- SV** Sätt fast plastskruvskyddet (PC) på skruvarna och bultändarna från insidan för att förebygga skada.
- IT** Fissa la copertura per le viti in plastica (PC) alle viti e alle estremità dei bulloni per prevenire danni e ferite.
- PL** Aby zapobiec zranieniu, zainstaluj plastikowe nakrętki (PC) na końce śrub i wkręćtów od wewnątrz.
- RO** Fixați protecția de plastic a șuruburilor (PC) pe marginea șuruburilor și bolțurilor din interior pentru a preveni accidentarea.
- BG** Завийте пластмасовите капачки, скриващи винтовете (PC) до краищата на болтовете и винтовете от вътрешната страна, за да избегнете наранявания.
- TR** Herhangi bir kazayı önlemek için, plastik kapağı (PC) içeriden vida ve pulların köşelerine sabitleyiniz.

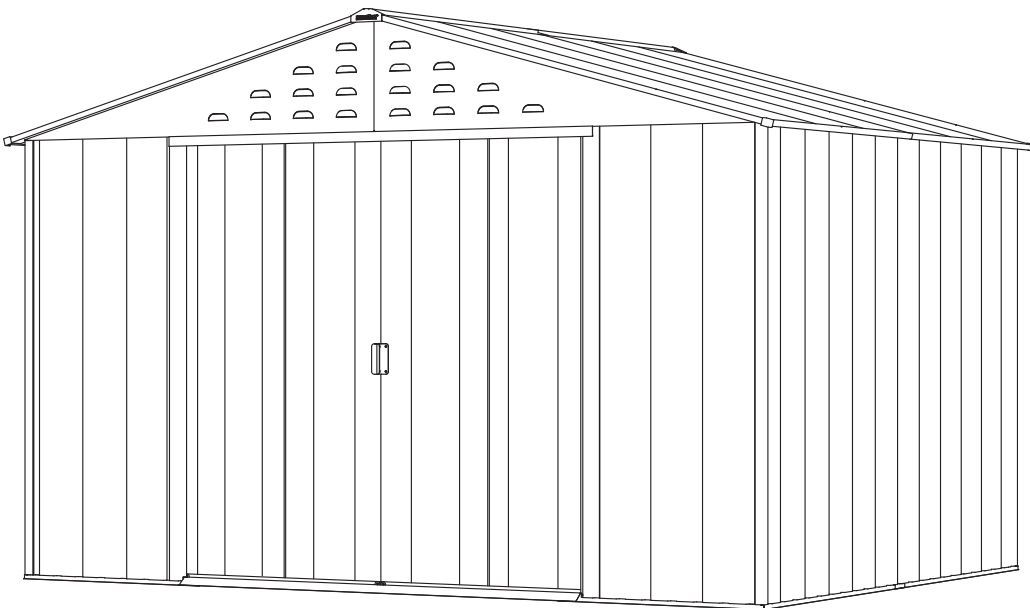
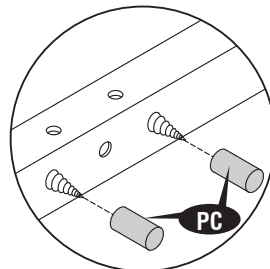
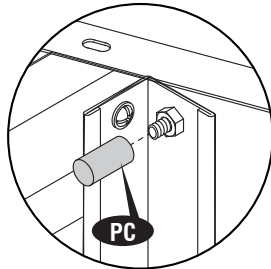

EN ADDITIONAL ACCESSORIES AVAILABLE

FR ACCESSOIRES ADDITIONNELS DISPONIBLES

DE WEITERES ZUBEHÖR

ES ACCESORIOS ADICIONALES DISPONIBLES

PT ACESSÓRIOS ADICIONAIS DISPONÍVEIS

NL EXTRA ACCESSOIRES AANWEZIG.

CS MOŽNÉ DALŠÍ DOPLŇKY

SK DOSTUPNÉ DODATOČNÉ PRÍSLUŠENSTVO

SL RAZPOLOŽLJIVA DODATNA OPREMA

HR DODATNI PROGRAMI RASPOLOŽIV

HU TOVÁBBI MEGVÁSÁROLHATÓ TARTOZÉKOK

SV YTTERLIGARE TILLGÄNGLIGA ACCESSOARERV

IT ACCESSORI SUPPLEMENTARI DISPONIBILI

PL DOSTĘPNE DODATKOWE AKCESORIA

RO ACCESORIILE SUPLIMENTARE DISPONIBILE

BG ДОПЪЛНИТЕЛНИ НАЛИЧНИ АКЕСОАРИ

TR EK AKSESUARLAR MEVCUTTUR



EN These accessories are required in case of heavy snow or high wind areas. Please choose relevant accessories according to your needs.

FR Ces accessoires sont exigés en cas de zones de la neige forte ou du vent fort. Veuillez choisir les accessoires appropriés selon vos besoins.

DE In Gebieten mit starken Schneefällen oder starkem Wind empfehlen wir das nachstehende Zubehör.

ES Estos accesorios son requeridas en caso de fuertes nevadas o zonas de alto viento. Por favor, elija los accesorios pertinentes de acuerdo a sus necesidades.

PT Estes acessórios são necessários em áreas de vento forte e/ou neve. Por favor, escolha os acessórios pertinentes de acordo com suas necessidades.

NL Deze accessoires zijn nodig in geval van hevige sneeuw val of gebieden waar het hard waait. Gebruik de accessoires die u nodig heeft.

CS Tyto doplňky se vyžadují v místech s velkým množstvím sněhu či silným větrem. Zvolte si prosím příslušné doplňky podle vašich potřeb.

SK Toto príslušenstvo sa vyžaduje v prípadoch ťažkého a veľkého množstva snehu alebo silného vetra. Vyberte si relevantné príslušenstvo na základe vašich potrieb.

SL Ta dodatna oprema se uporablja v primeru velike količine zapadlega snega ali če lopa stoji na zelo vetrovnem območju. Izberite ustrezno opremo glede na to, kaj dejansko potrebujete.

HR Ovi dodaci su potrebni u slučaju teškog snijega ili jak vjetar regija. Molimo odaberite relevantne dodatne opreme prema vašim potrebama.

HU Ezekre a tartozékokra sűrű havazás esetén vagy erősen szeles területeken van szükség. Kérjük, igénye szerint válasszon a megfelelő tartozékok közül.

SV Dessa accessoarer behövs vid tung snö eller i områden med hård vind. Var god välj relevanta accessoarer efter behov.

IT Questi accessori sono importanti in caso di neve o aree soggette a forti venti. Per favore, scegli questi accessori in base ai tuoi bisogni.

PL Akcesoria te są wymagane w przypadku terenów, na których zdarzają się duże opady śniegu lub silnewiatry. Wybierz odpowiednie akcesoria w zależności od potrzeb.

RO Aceste accesorii sunt necesare în cazul în cazul în care apar depuneri masive de zăpadă sau în zonele în care bate vânt puternic. Vă rugăm alegeți accesorii potrivite nevoilor dumneavoastră.

BG Тези акесоари се изискват в случай на тежък сняг или при райони със силен вятър. Моля подберете съответните акесоари според нуждите.

TR Bu aksesuarlar yoğun kar yağışı ya da kuvvetli rüzgar alan bölgelerde gereklidir. Lütfen ihtiyaçlarınıza uygun gerekli aksesuarları seçiniz.

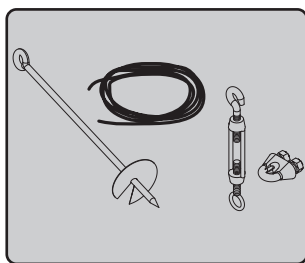

1

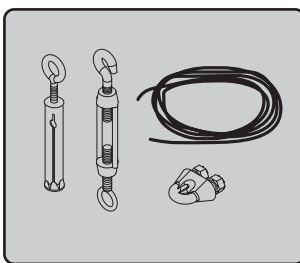

2

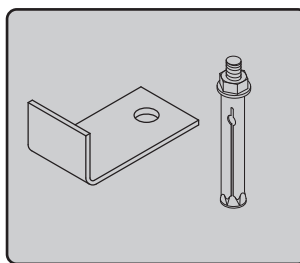

3

1

- | | |
|------------------------------------|--------------------------------|
| EN ANCHOR KIT (Soil) | HR SIDRO KOMPLET (tla) |
| FR KIT D'ANCRE (Sol) | HU RÖGZÍTŐ FELSZERELÉS (Talaj) |
| DE ANKER-KIT (Boden) | SV FÖRANKRINGS-KIT (Jord) |
| ES KIT DE ANCLAJE (Suelo) | IT KIT DI ANCORAGGIO (Suolo) |
| PT KIT DE APOIO (Solo) | PL ZESTAW DO MOCOWANIA (Grunt) |
| NL ANKER GEREEDSCHAP (bodem) | RO SET DE ANCORARE (ÎN SOL) |
| CS KOTEVNÍ SOUPRAVA (Hlína) | BG КОМПЛЕКТ АНКЕРИ (Почва) |
| SK UKOTVOVACIE PRÍSLUŠENSTVO (zem) | TR EKLEMLEME KİTİ (Toprak) |
| SL SIDRNA OPREMA (zemlja) | |

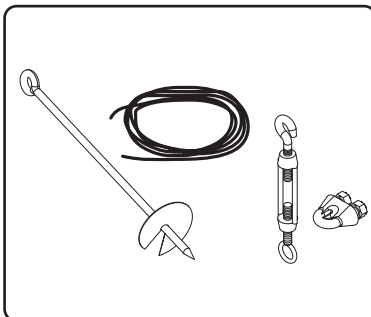

- EN Wire rope with twist augers for sheds installed with foundation (Wood / Metal) on soil.
For heavy wind area.
- FR Fil de fer avec des foreuses de torsion pour des hangars installés avec la base (en métal / en bois) sur le sol. **Pour la zone du vent fort.**
- DE Seil mit Erdbohrer bei einem Unterbau (Holz / Metall) auf dem Boden.
Für Gebiete mit starkem Wind.
- ES De cable metálico con barrenas helicoidales para cobertizo s instalados con la fundación (Metal y madera) en el suelo. **Para el área del fuerte viento.**
- PT Cabo metálico com brocas para galpões instalados com base (Madeira/Metal) em solo.
Para áreas de vento forte.
- NL Bedrading met kronkelige grondboren voor het schuurtje moet met fundering worden geïnstalleerd (hout/metaal) op bodem. **Voor hevige wind gebieden.**
- CS Drátěné lano se vrtáky pro kůlny postavené se základy (dřevo / kov) na hlíně.
Pro místa se silným větrem.
- SK Drôtené lano s krútenými špirálovitými šnekmi pre hangáre nainštalované zo základom (drevo/kov) na zemi. **Pre oblasti so silným vetrom.**
- SL Žična vrv z velikim svedrom z enojno spiralo za lope nameščene na temelju (les/kovina) na zemlji.
Za zelo vetrovna območja.
- HR čelikčelo s okretati svrdlom za baca instaliran s temelja (Drvo / Metal) na tlu.
Za teške vjetar području.
- HU Drótkötél spirálfúrókkal alappal rendelkező kerti fészerekhez (Fa / fém) talajon.
Erősen szeles területekre.
- SV Wirelås med tvistborr för skjul installerade med grund (trä / metall) på jord.
För områden med hård vind.
- IT Fune con trivella a spirale per capannoni installati con fondamenta (legno/metallo) sul suolo.
Per aree soggette a forte vento.
- PL Lina stalowa ze świdrami dla magazynków montowanych na pod stawie (Drewno/Metal) do gruntu.
Przeznaczone do użytkowania na obszarach występowania silnych wiatrów.
- RO Cabluri cu burghie răsucite pentru magazinele asamblate pe fundație (Lemn / Metal) în sol.
Pentru zonele în care bate vânt puternic.
- BG Стоманено въже с извити сонди за заслони, монтирани върху фундаменти (Дърво / Метал) върху почва.
За силно ветровита зона.
- TR Zemin (tahta/metal) toprak üstüne gecekler şekilde inşa edilen barınaklar için burgulu matkap ve tel ip.
Kuvvetli rüzgar alan yerler için.

2

- EN ANCHOR KIT (Concrete)
 FR KIT D'ANCRE (Béton)
 DE Verankerungsset (Beton)
 ES KIT DE ANCLAJE (hormigón)
 PT KIT DE APOIO (Concreto)
 NL ANKER GEREEDSCHAP (Beton)
 CS KOTEVNÍ SOUPRAVA (Beton)
 SK UKOTVOVACIE PRÍSLUŠENSTVO (betón)
 SL SIDRNA OPREMA (beton)
- HR SIDRO KOMPLET (beton)
 HU RÖGZÍTŐ FELSZERELÉS (Beton)
 SV FÖRANKRINGS-KIT (Betong)
 IT KIT DI ANCORAGGIO (cemento)
 PL ZESTAW DO MOCOWANIA (Beton)
 RO SET DE ACORARE (Beton)
 BG КОМПЛЕКТ АНКЕРИ (Бетон)
 TR EKLEMLEME KİTİ (Beton)

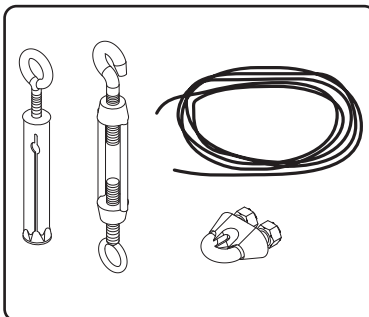

- EN Eye bolt with wire rope for sheds installed with foundation (Wood / Metal) on concrete.
For heavy wind area.
- FR OEil à queue filetée avec fil en fer pour des hangars installés avec la base (en métal / en bois) sur le béton.
Pour la zone du vent fort.
- DE Ringschraube mit Seil für Gerätehäuser mit einem Unterbau (Holz / Metal) auf Beton.
Für Gebiete mit starkem Wind.
- ES Perno de Ojo con el cable de alambre para las vertientes instaladas con la fundación (Metal y madera) en el suelo. **Para el área del fuerte viento.**
- PT Cavilha com cabo de aço para galpões instalados com base (Madeira/Metal) em concreto.
Para áreas de vento forte.
- NL Eyebolt met stalendraad voor schuurtje moet worden geïnstalleerd met fundering (hout/metaal) op beton.
Voor hevige wind gebieden.
- CS Oka s drátěným lanem pro kůlny postavené se základy (dřevo / kov) na betonu.
Pro místa se silným větrem.
- SK Šrob s okom s drôteným lanom pre hangáre nainštalované so základom (drevo/kov) na betóne.
Pre oblasti so silným vetrom.
- SL Očesni vijak z žično vrvjo za lope nameščene na temelju (les/kovina) na betonu.
Za zelo vetrovna območja.
- HR oči vijak žičane užadi za baca Installer sa temelja (Drvo / Metal) na betonu.
Za teške vjetar području.
- HU Gyűrűs csavar drótkötéllal alappal rendelkező kerti fészerekhez (Fa / fém) betonon.
Erősen szeles területekre.
- SV Stagögla med wirelås för skjul som installerats med grund (Trä / Metall) på betong.
För områden med hård vind.
- IT Vite ad occhio con fune per capannoni installati con fondamenta (legno/metallo) sul cemento.
Per aree soggette a forte vento.
- PL Śruba z uchem z liną stalową dla magazynków montowanych na podstawie (Drewno/Metal) do betonu.
Przeznaczone do użytkowania na obszarach występowania silnych wiatrów.
- RO Șurub cu ochi atașat la un cablu pentru magazinele asamblate pe fundație (Lemn / Metal) în beton.
Pentru zonele în care bate vânt puternic.
- BG Шарнирен болт със стоманено въже за заслони, инсталирани с фундамент (Дърво / Metal) върху бетон.
За силно ветровита зона.
- TR Zemin (tahta/metal) beton üstüne gelecek şekilde inşa edilen barnaklar için halkalı vida ve tel ip.
Kuvvetli rüzgar alan yerler için.

3

EN ANCHOR KIT (Foundation)

FR KIT D'ANCRE (Base)

DE ANKER-KIT (Fundament)

ES KIT DE ANCLAJE (Fundación)

PT KIT DE APOIO (Base)

NL ANKER GEREEDSCHAP (Fundering)

CS KOTEVNÍ SOUPRAVA (Základy)

SK UKOTVOVACIE PRÍSLUŠENSTVO (základ)

SL SIDRNA OPREMA (temelj)

HR SIDRO KOMPLET (Temelj)

HU RÖGZÍTŐ FELSZERELÉS (Alap)

SV FÖRANKRINGS-KIT (Grund)

IT KIT DI ANCORAGGIO (Fondamenta)

PL ZESTAW DO MOCOWANIA (Podstawa)

RO SET DE ACORARE (Fundatie)

BG КОМПЛЕКТ АНКЕРИ (Фундамент)

TR EKLEMLEME KİTİ (Zemin)

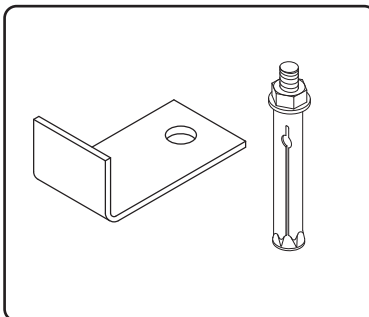

EN Strap clamping for shed assembly with foundation (Wood / Metal) on concrete.
To prevent shed from displacement.

FR Encastrement pour le hangar avec la base (en métal / en bois) sur le béton.
Pour empêcher le hangar du déplacement.

DE Ankerbolzen für Gerätehäuser mit einem Unterbau (Holz / Metal) auf Beton.
Um ein Verschieben des Gerätehauses zu vermeiden.

ES Correa de sujeción para armar el cobertizo con la fundación (Metal y madera) en el hormigón.
Para evitar que se desprenden de desplazamiento.

PT Cinta de fixação para montagem do galpão com base (madeira/ metal) em concreto
Para evitar deslocamento do galpão.

NL Klemband voor montage van schuurtje met fundering (hout/metaal) op beton.
Voorkom het schuurtje van verschuiven.

CS Připevnění pro kůlny postavené se základy (dřevo / kov) na betonu.
K prevenci pohybu kůlny.

SK Zvieranie popruhu, resp. zvierací popruh pre hangáre zostavené so základom (drevo/kov) na betóne.
Na zabránenie premiestnenia hangáru.

SL Jermena za pritrdjevanje lope nameščene na temelju (les/kovina) na betonu.
Za preprečevanje premika lopa.

HR Privezati kaišem za proliše stezanja montaža s temeljem (Drvo / Metal) na betonu.
Da biste spriječili prolivena od pomaka.

HU Szorítócsavar az alappal rendelkező kerti fészker összeszereléséhez (Fa / fém) betonon.
Megakadályozza a kerti fészker elmozdulását.

SV Spänn fast skjulmontage vid grunden (Trä / Metall) på betong.
För att förebygga förskjutning.

IT Cinghia di bloccaggio per l'assemblaggio del capannone con fondamenta (legno/metallo) sul cemento.
Per evitare un dissestamento del capannone.

PL Lina stalowa ze świdrami dla magazynków montowanych na pod stawie (Drewno/Metal) do gruntu.
Przeznaczony do użytkowania na obszarach występowania silnych wiatrów.

RO Curea de prindere pentru magazinele asamblate pe fundație (Lemn/Metal) în beton.
Prevenirea deplasării magaziei.

BG Затягане с връзка за сглобяване на заслон с фундамент (Дърво / Метал) върху бетон.
За да предпазите заслона от изместване.

TR Zemin (tahta/metal) beton üstüne gelecek şekilde inşa edilen barınaklar için mengene.
Barınağın kaymasını engellemek için.



U.S. Polymers, Inc.
1057 S. Vail Ave
Montebello, CA 90640,
United States of America

www.duramaxbp.com