

Bemerkung: die Ansicht von Turen, Fenster und anderen Teilen kann abweichen von diesem Bild

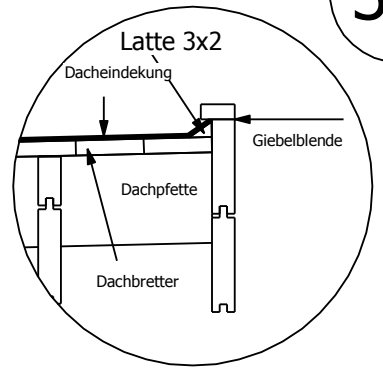

3,0

Grundriss

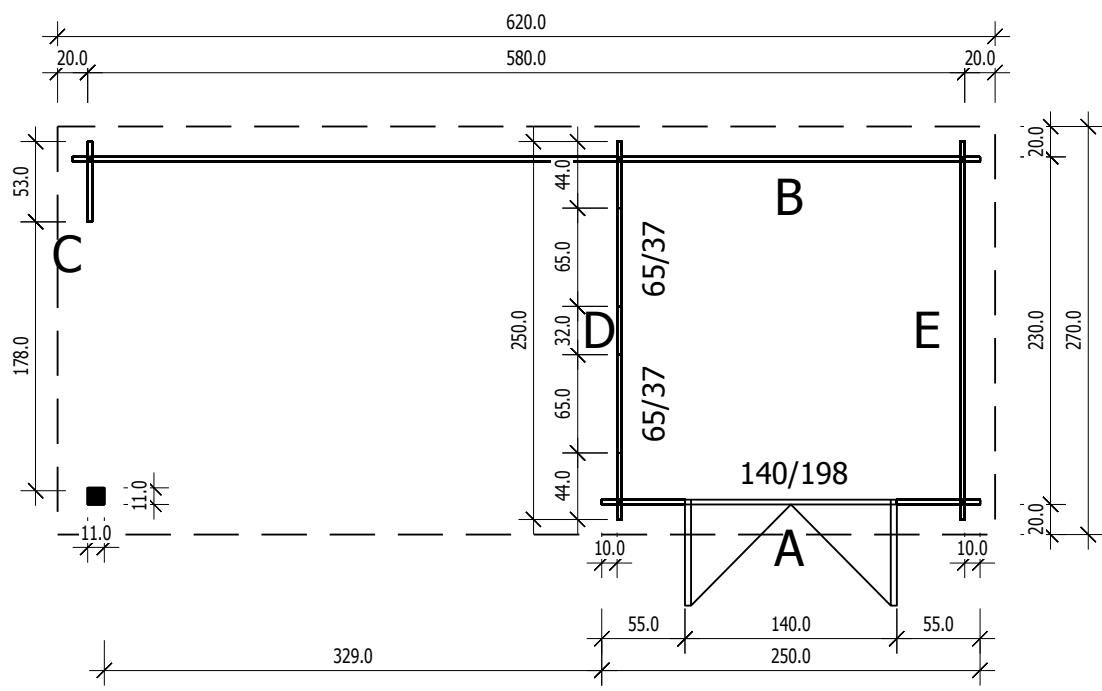

Schnitt

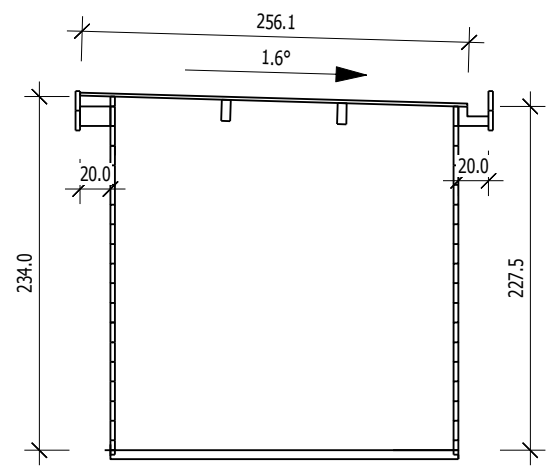

Grundrahmenplan

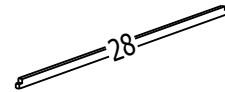
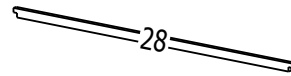
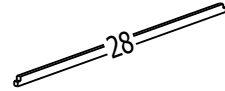
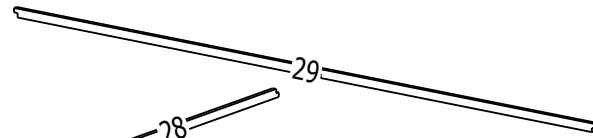
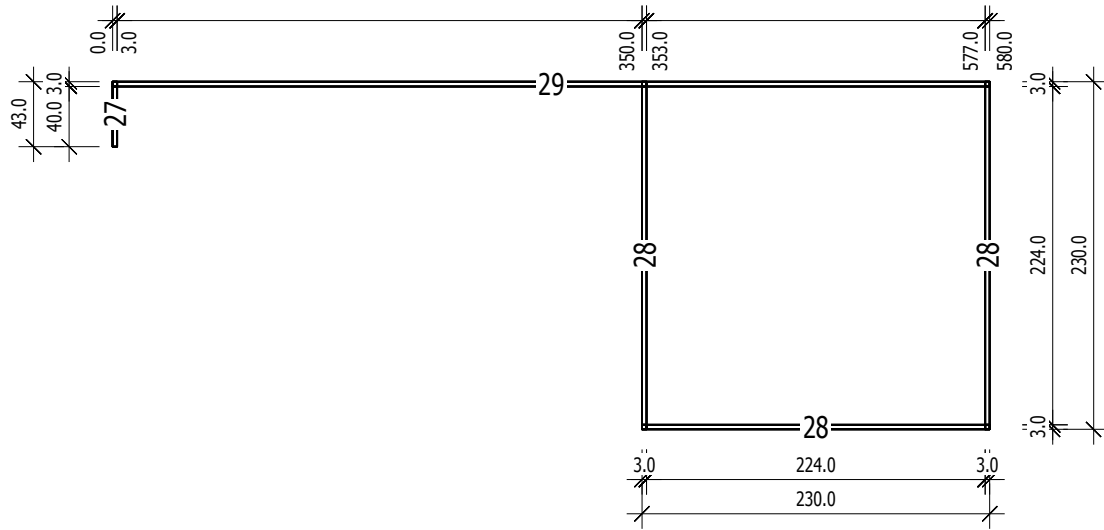

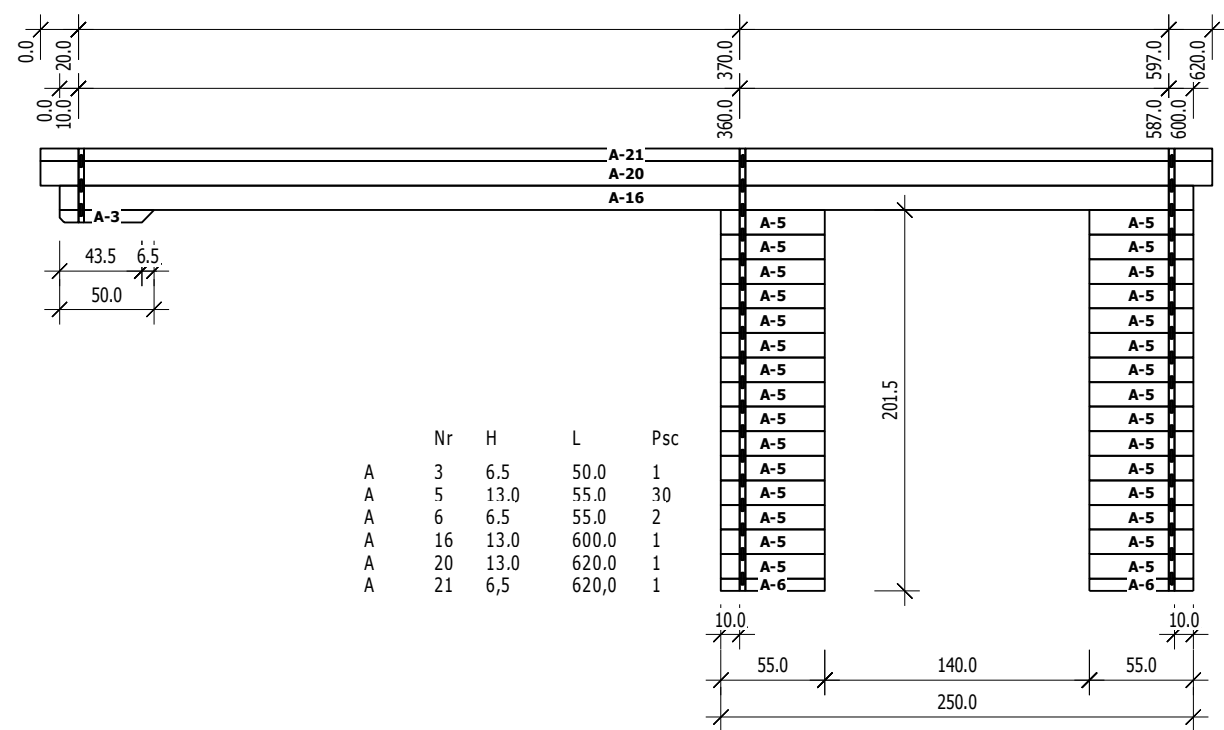

	Nr	H	L	Psc
A	3	6.5	50.0	1
A	5	13.0	55.0	30
A	6	6.5	55.0	2
A	16	13.0	600.0	1
A	20	13.0	620.0	1
A	21	6.5	620.0	1

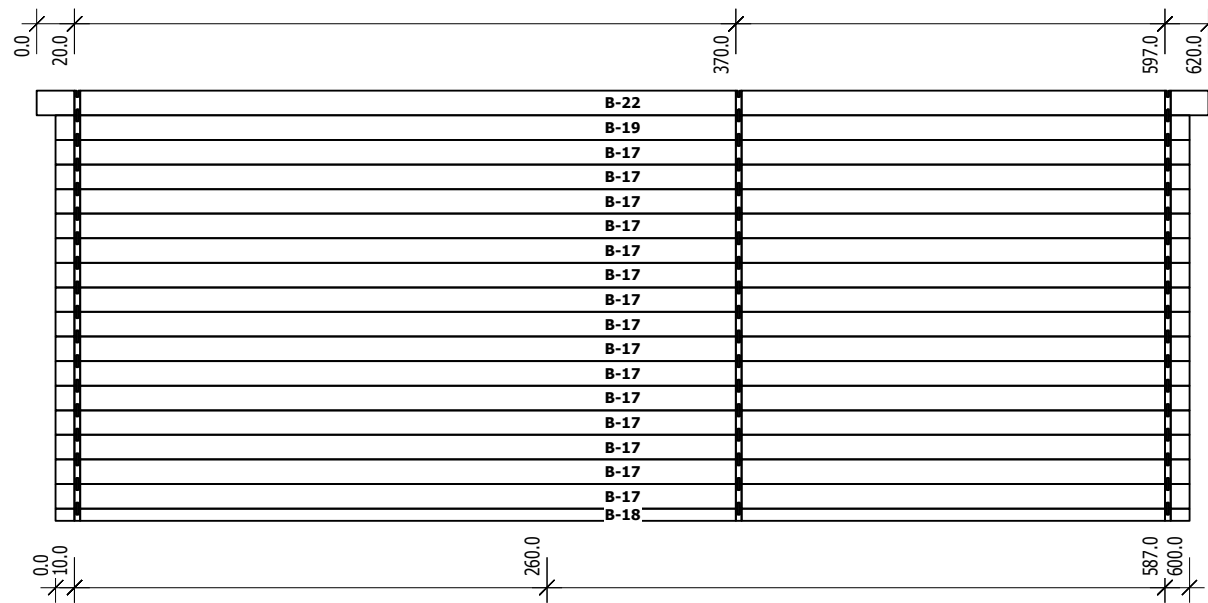

	Nr	H	L	Psc
B	17	13.0	600.0	15
B	18	6.5	600.0	1
B	19	13.0	600.0	1
B	22	13.0	620.0	1

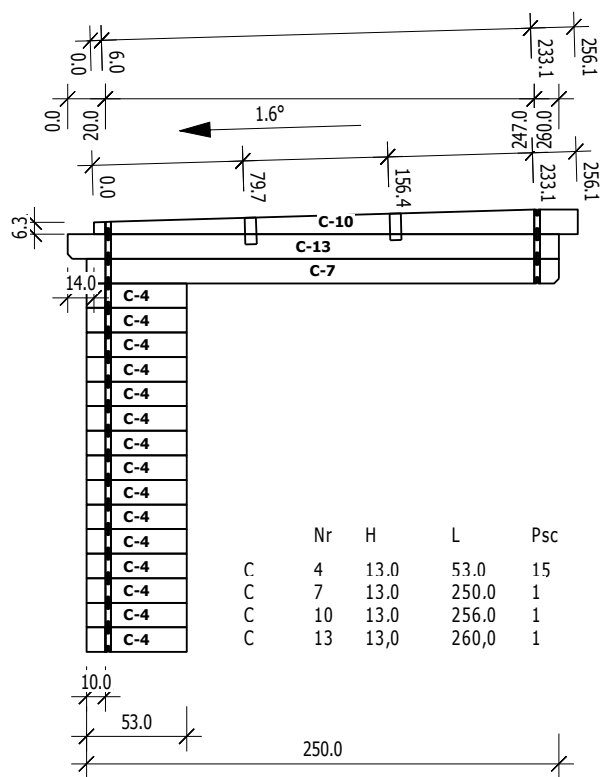

	Nr	H	L	Psc
C	4	13.0	53.0	15
C	7	13.0	250.0	1
C	10	13.0	256.0	1
C	13	13.0	260.0	1

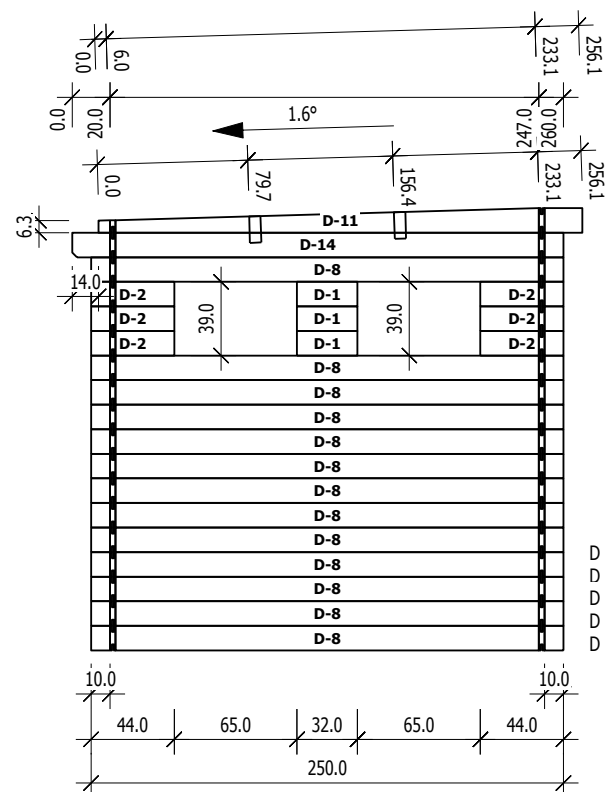

	Nr	H	L	Psc
D	1	13.0	32.0	3
D	2	13.0	44.0	6
D	8	13.0	250.0	13
D	11	13.0	256.0	1
D	14	13.0	260.0	1

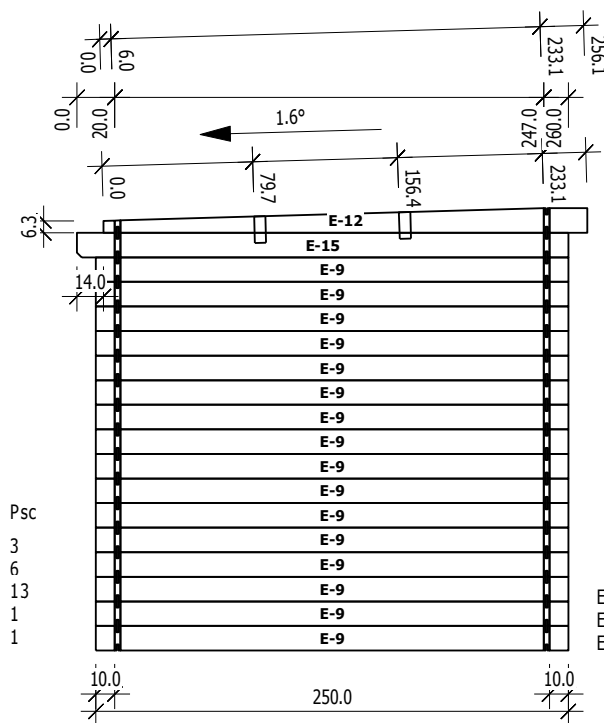

	Nr	H	L	Psc
E	9	13.0	250.0	16
E	12	13.0	256.0	1
E	15	13.0	260.0	1