

5x5+2 / 50 / 2013

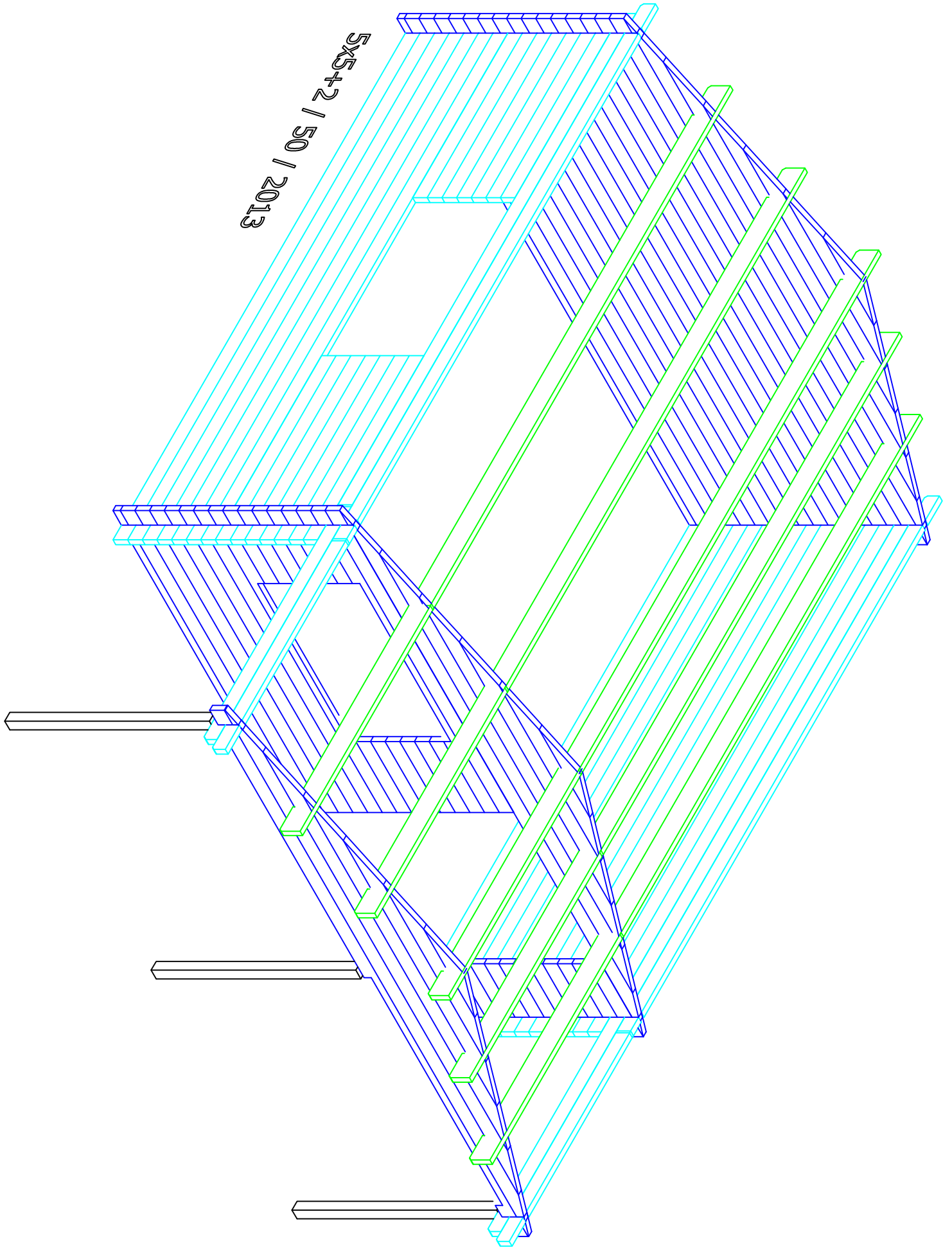

5x5+2 / 50 / 2013

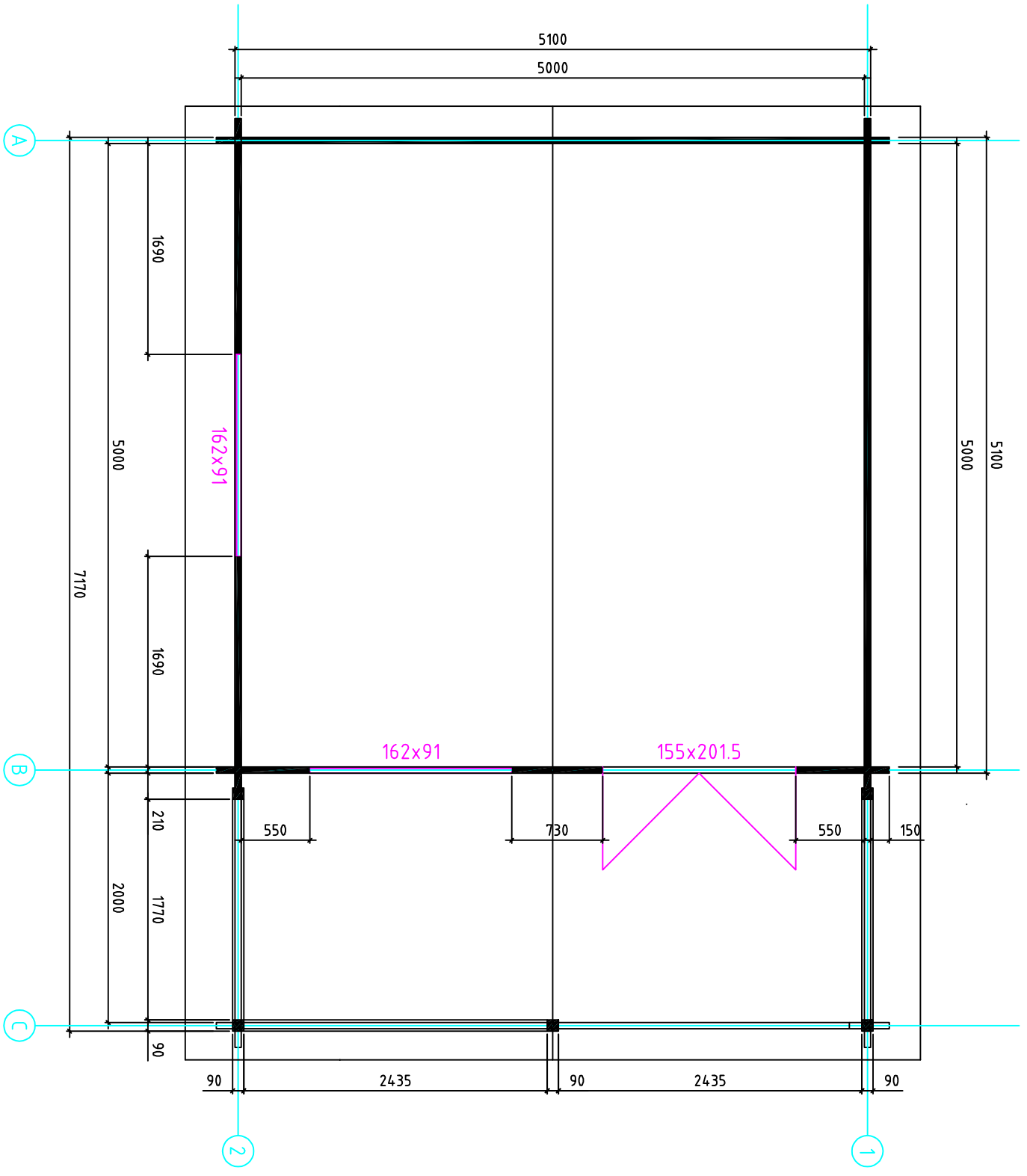

Wand 1 ↗

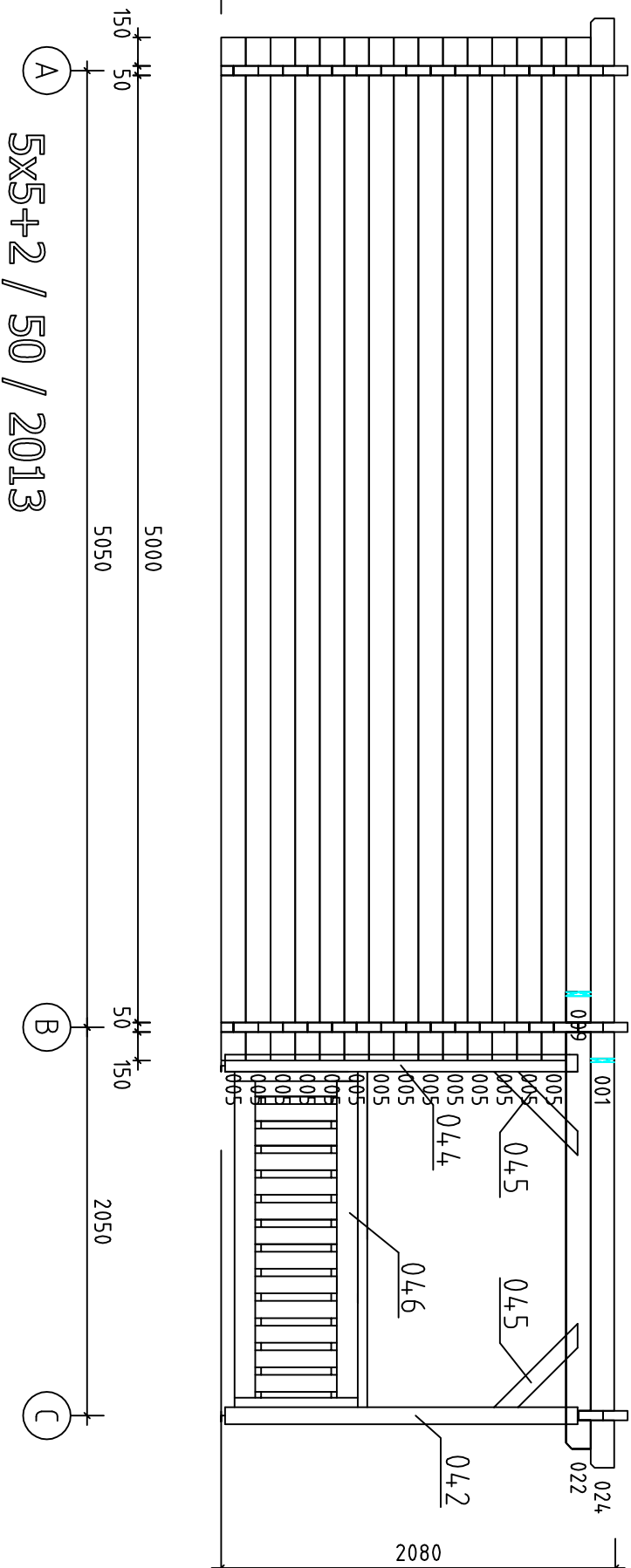

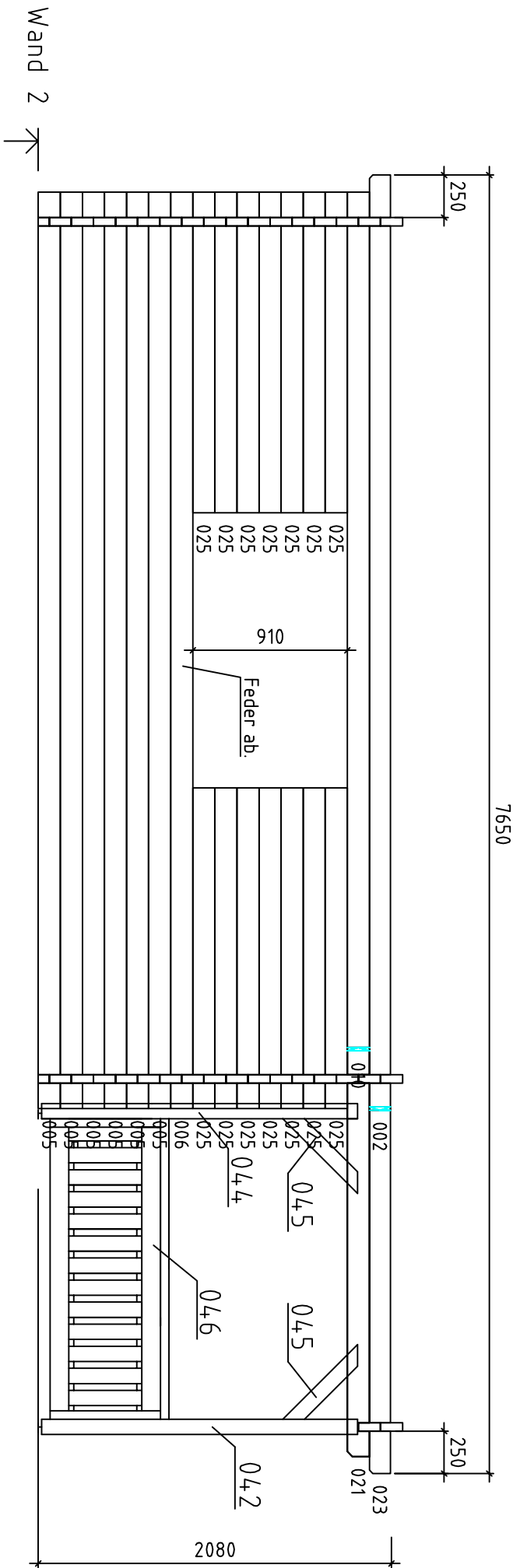

5x5+2 / 50 / 2013

A

B

C

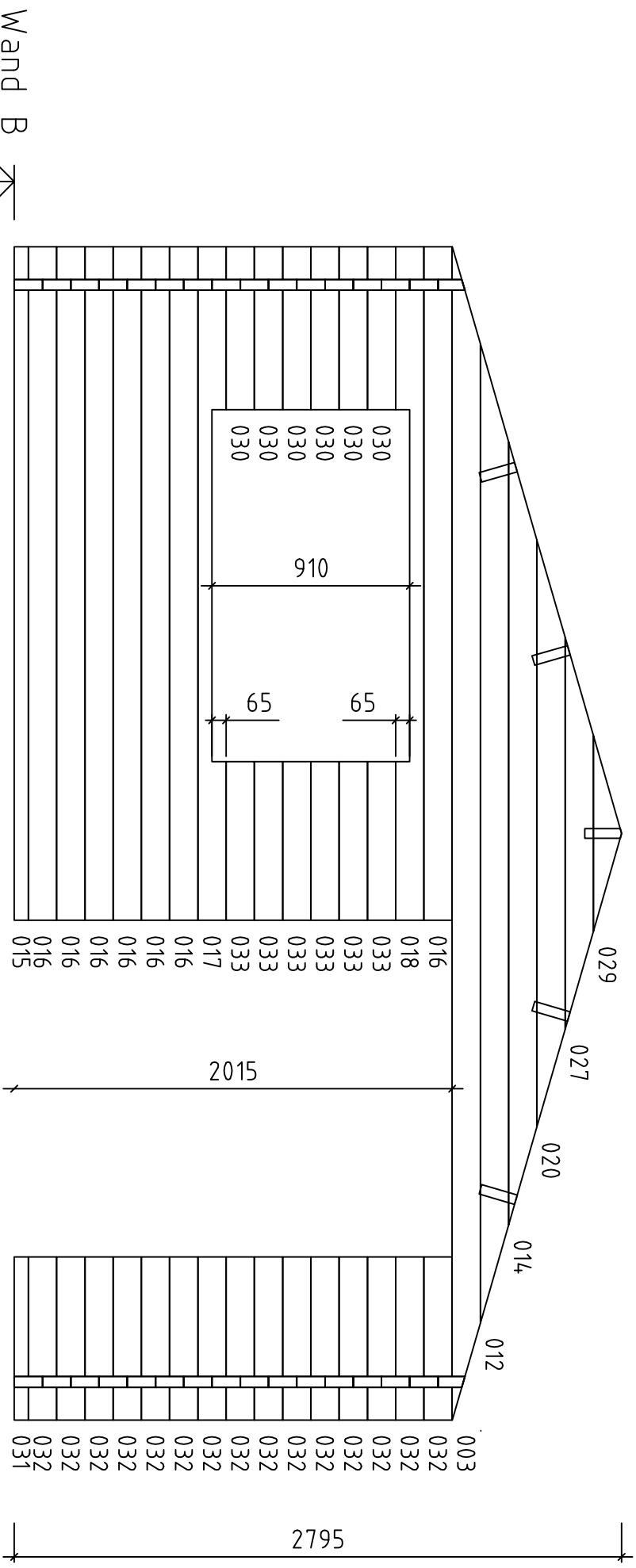

② 5x5+2 / 50 / 2013





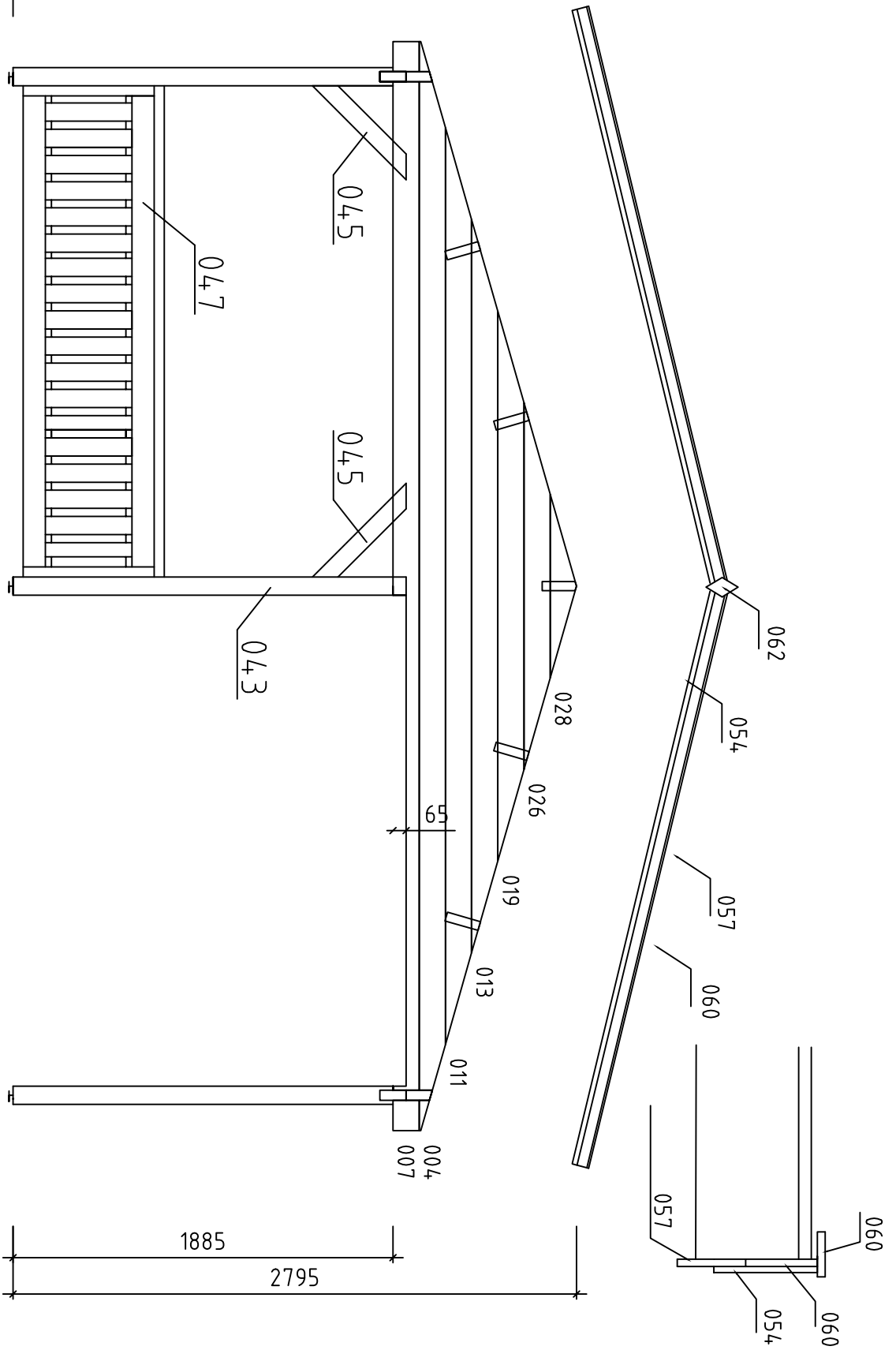

①

Wand C ↗

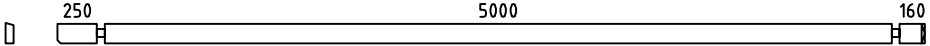
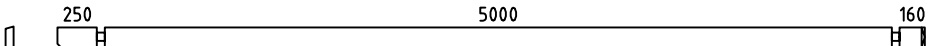
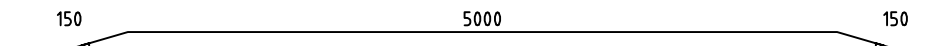
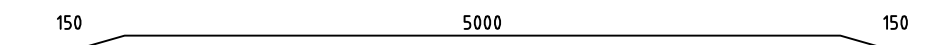
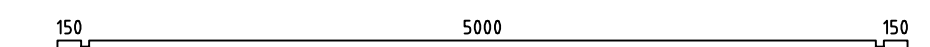
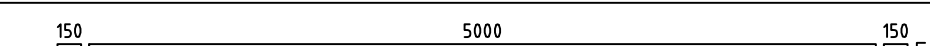
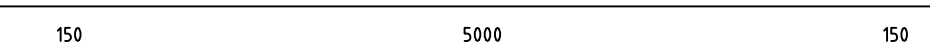
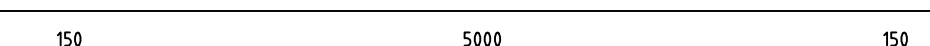
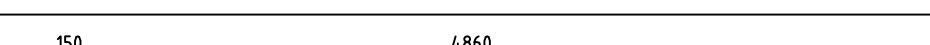
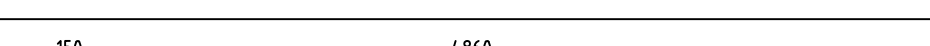
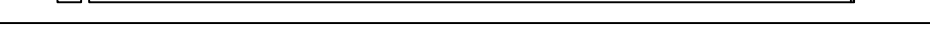
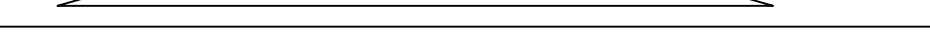
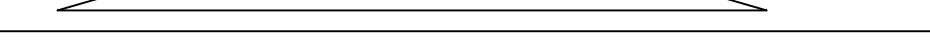
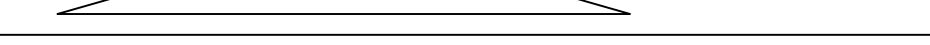
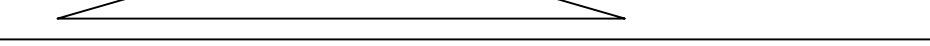
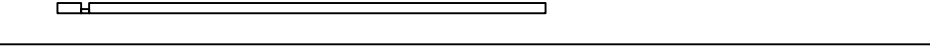
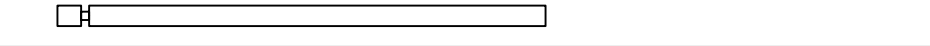
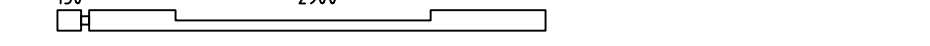
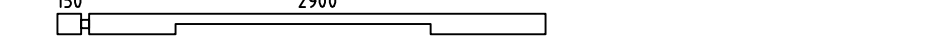

② 5x5+2 / 50 / 2013

①

Pos	5x5+2 / 50 / 2013	ST	F (mm)	L (mm)
001		1	50x124	5510
002		1	50x124	5510
003		2	50x130	5400
004		1	50x130	5400
005		35	50x130	5400
006	 Feder ab	1	50x130	5400
007		1	50x130	5400
008		1	50x65	5400
009		1	50x130	5060
010		1	50x130	5060
011		1	50x130	4545
012		2	50x130	4506
013		1	50x130	3636
014		2	50x130	3605
015		1	50x65	3100
016		7	50x130	3100
017		1	50x130	3100
018		1	50x130	3100
019		1	50x130	2727
020		2	50x130	2703
021		1	50x130	2410
022		1	50x130	2410
023		1	50x124	2160
024		1	50x124	2160
025		14	50x130	1890
Kood	Materjal	File	trükk.dwg	Leht 1/2

Pos	5x5+2 / 50 / 2013		ST	F (mm)	L (mm)
026			1	50x130	1818
027			2	50x130	1802
028			1	50x130	909
029			2	50x130	901
030			6	50x130	750
031			1	50x65	750
032			15	50x130	750
033			6	50x130	730
PR1			4	45x190	5335
PR3			1	45x190	5335
PR2			4	45x190	2335
PR4			1	45x190	2335
051	Dachbretter		172	90x20	3000
052	Dachpappenleiste		12	20x40	2550
054	Giebelbretter		3	20x120	3200
057	Giebelbretter		3	20x90	3200
060	Giebeldeckbretter		6	20x70	3200
062	Giebelsegment		2		
Kood		Materjal	File trükk.dwg		Leht 2/2

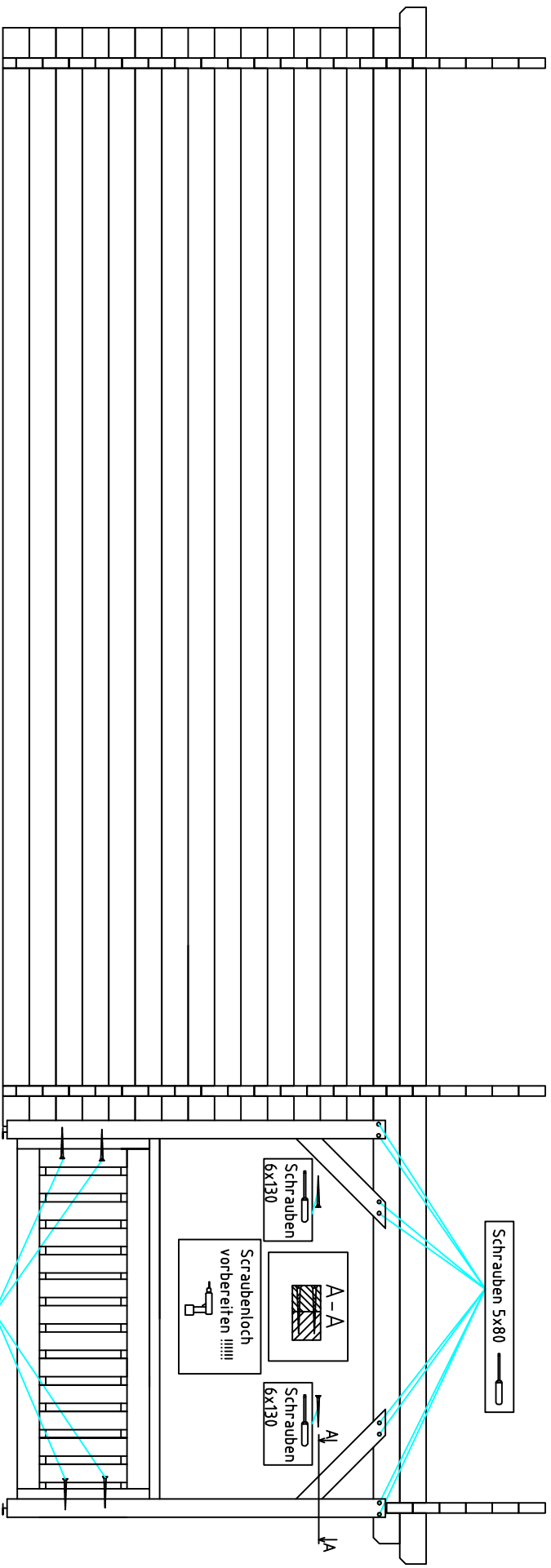

Wand 2 ↗

5X5+2 / 50 / 2013

5050

2050

(A)

(B)

(C)

Schrauben 5x80

Schrauben 6x130

A-A

Schrauben 6x130

Schraubenloch vorbereiten iiiiii

Schrauben 5x80

JA

Wand 1 ↗

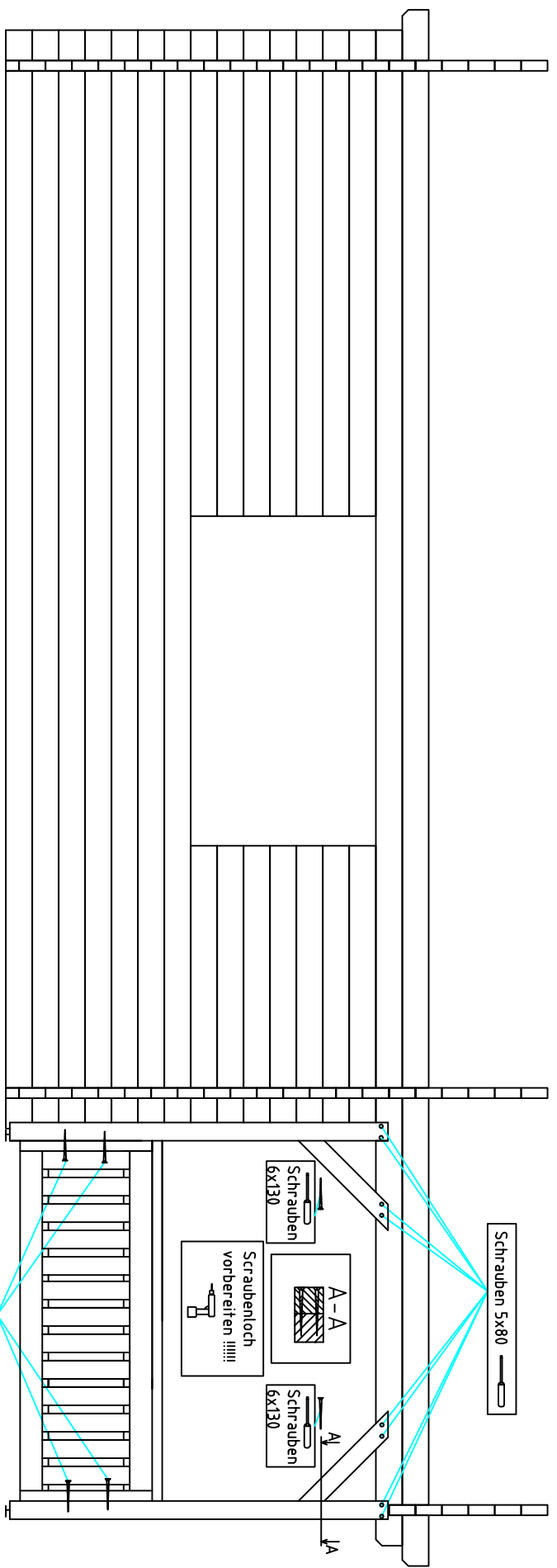

5050

2050

(A)

(B)

(C)

5x5+2 / 50 / 2013

Wand 1 ↗

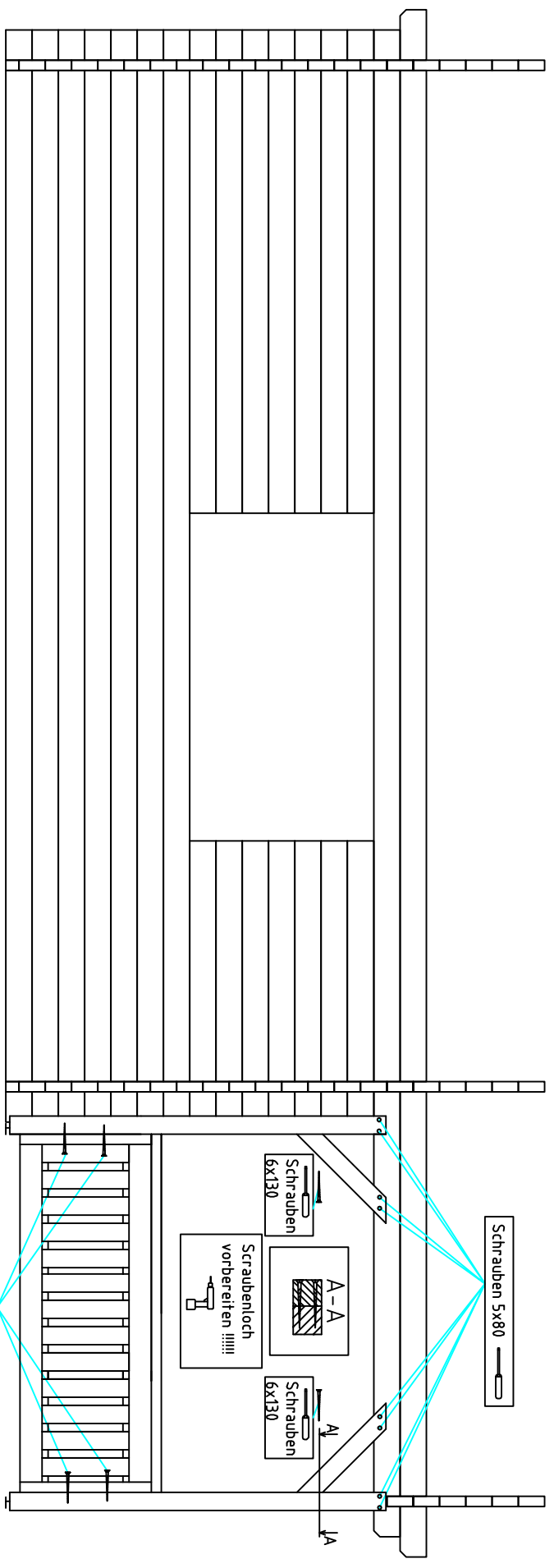

5050

2050

(A)

(B)

(C)

5x5+2 / 50 / 2013

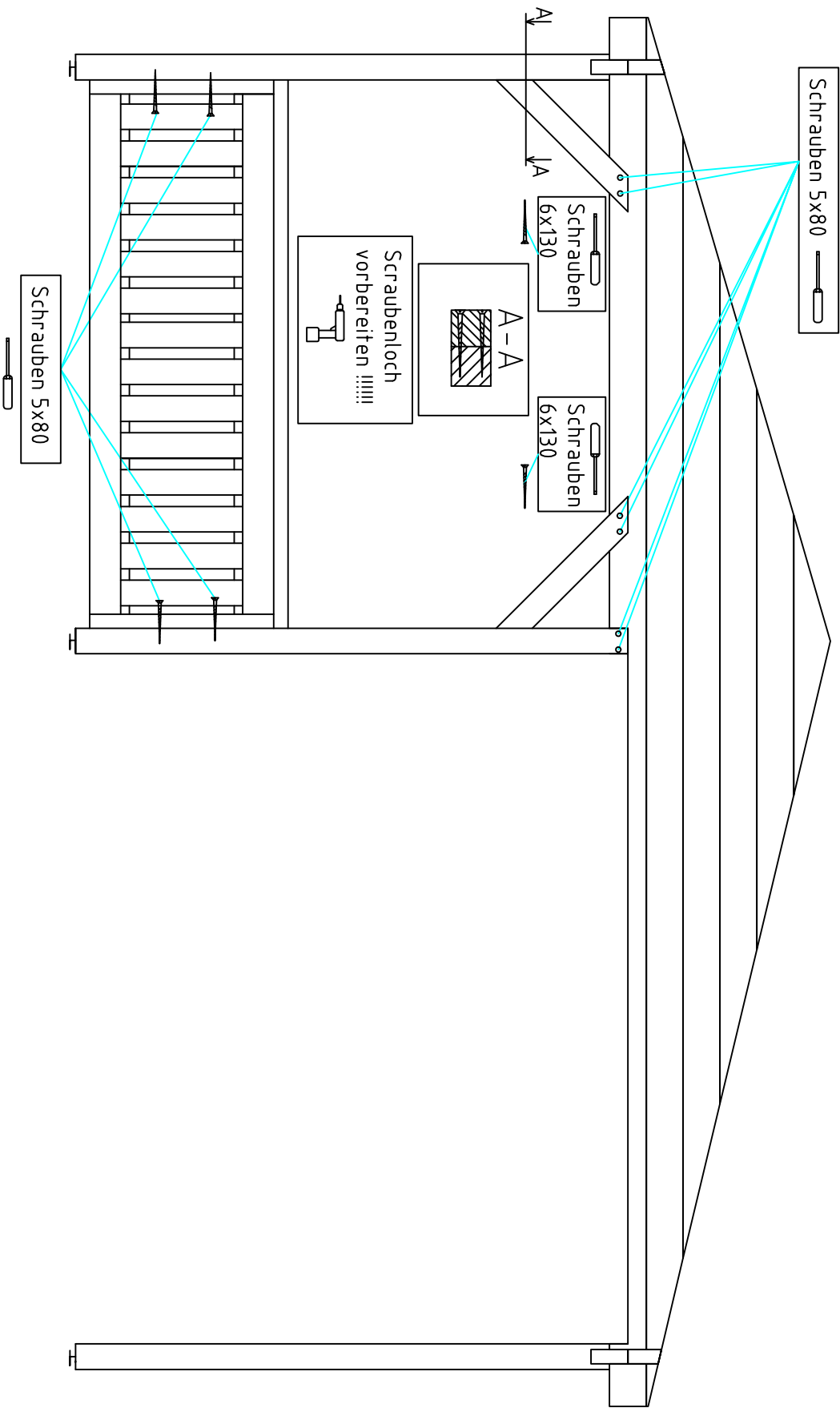

5050

①

5x5+2 / 50 / 2013

②

Doppeltür

Beschlag:

Türklinken mit der Lasche = 1 Kmp.

Schraubeh 5x80mm = 4 St.

Schnepper mit Schlüsseln = 1 Kmp.

Metalblechen (zwei St.) Pos. 5,
befinden sich auf untere oder
obene Türflügelkante.

Schrauben 5x80

Schrauben 5x80

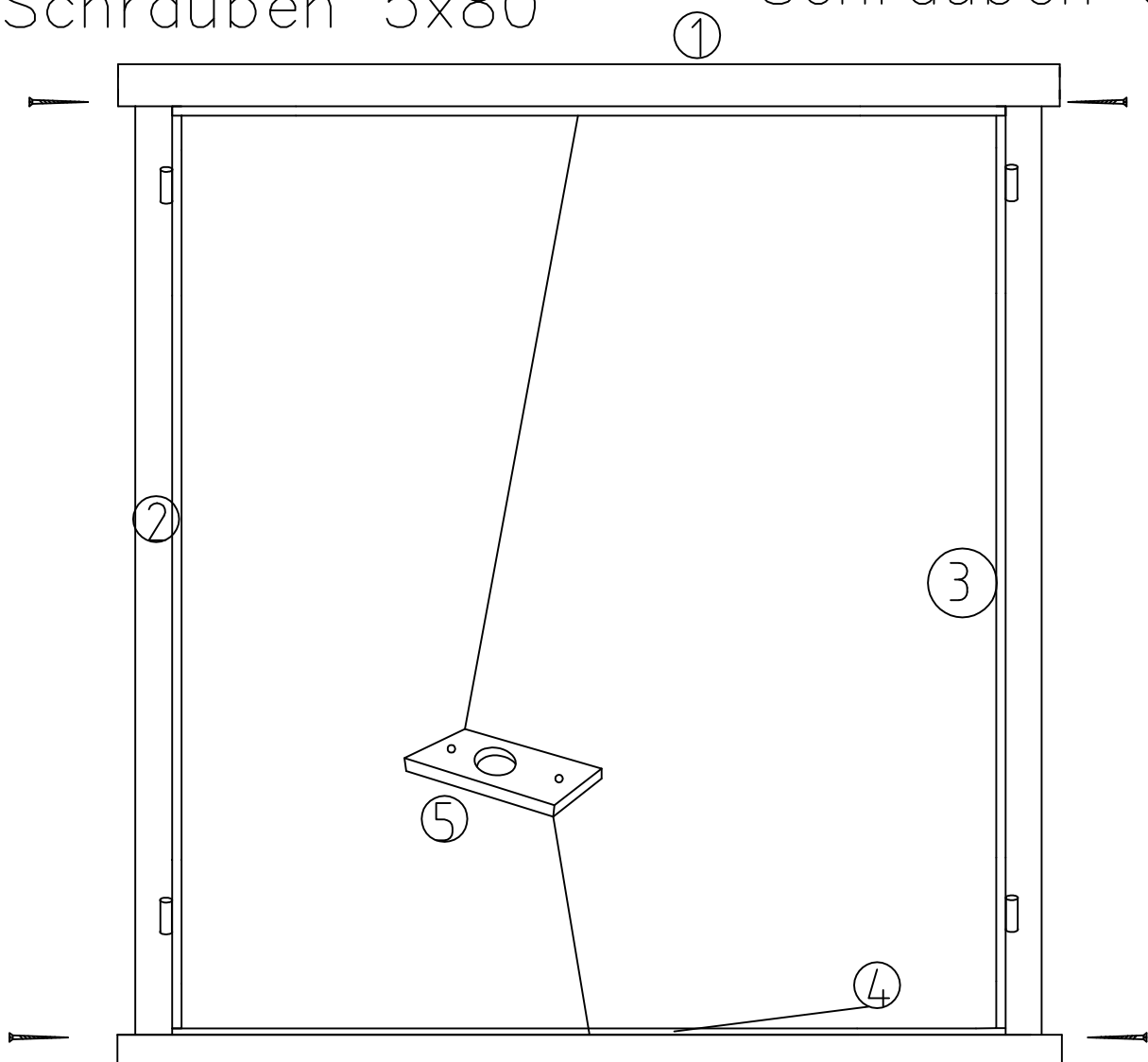

Schrauben 5x80

Schrauben 5x80