

GARAGE 3352 / 40 / 09 /

Garage 3352 / 40 / 09

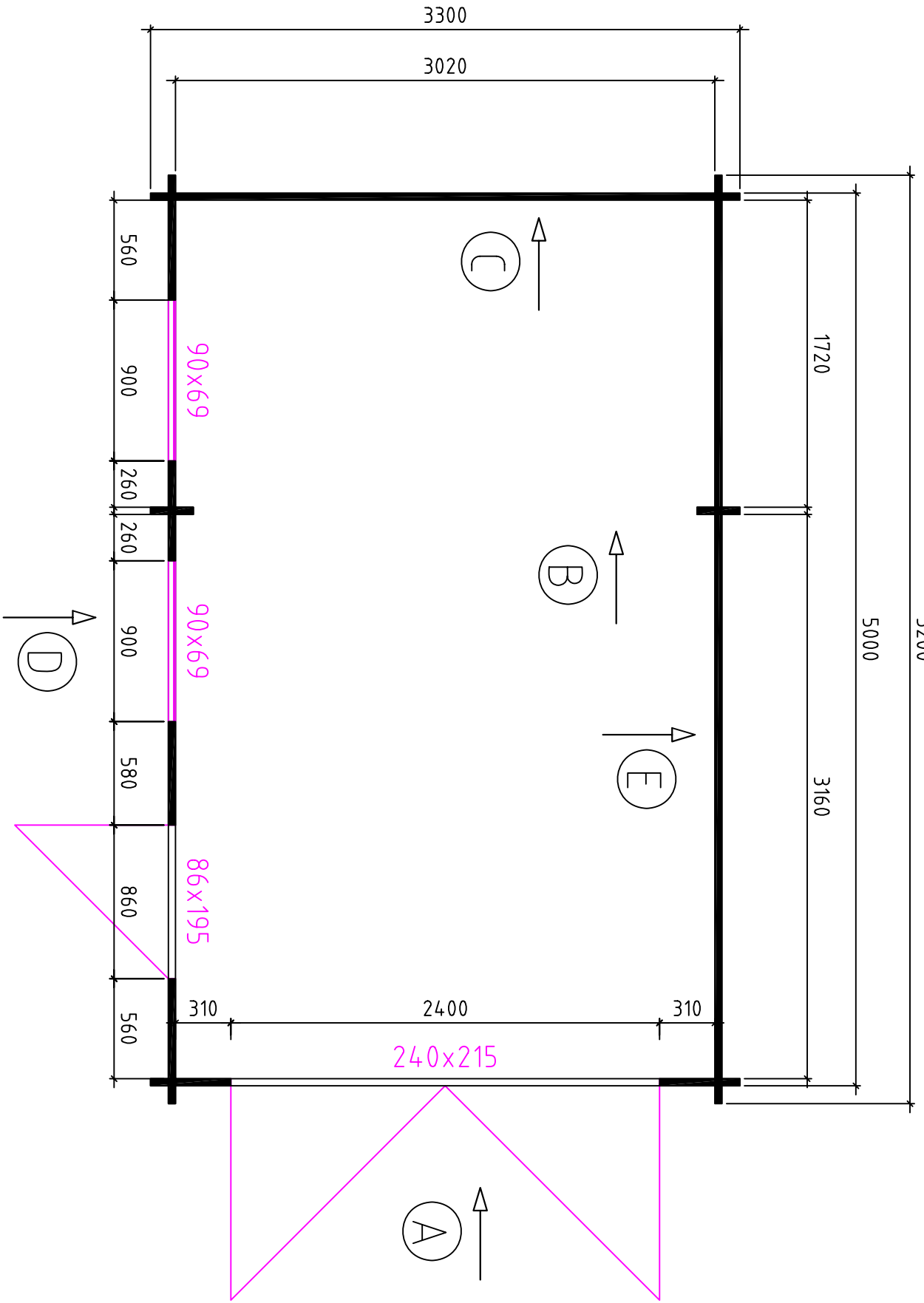

Grundplan

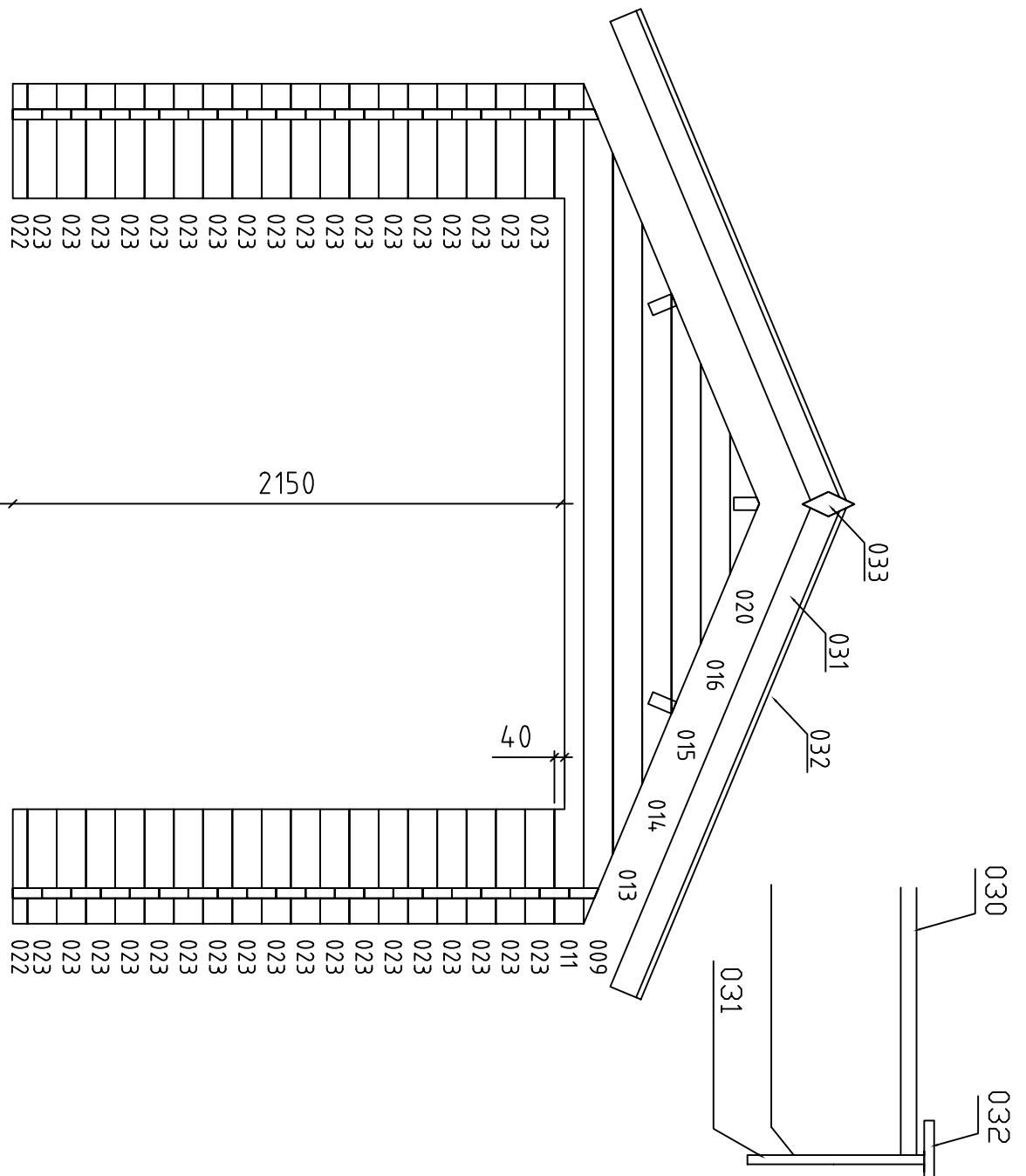

Garage 3352 / 40 / 09

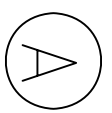

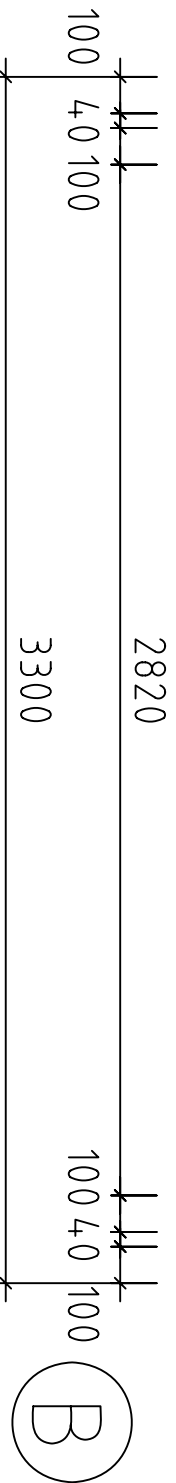
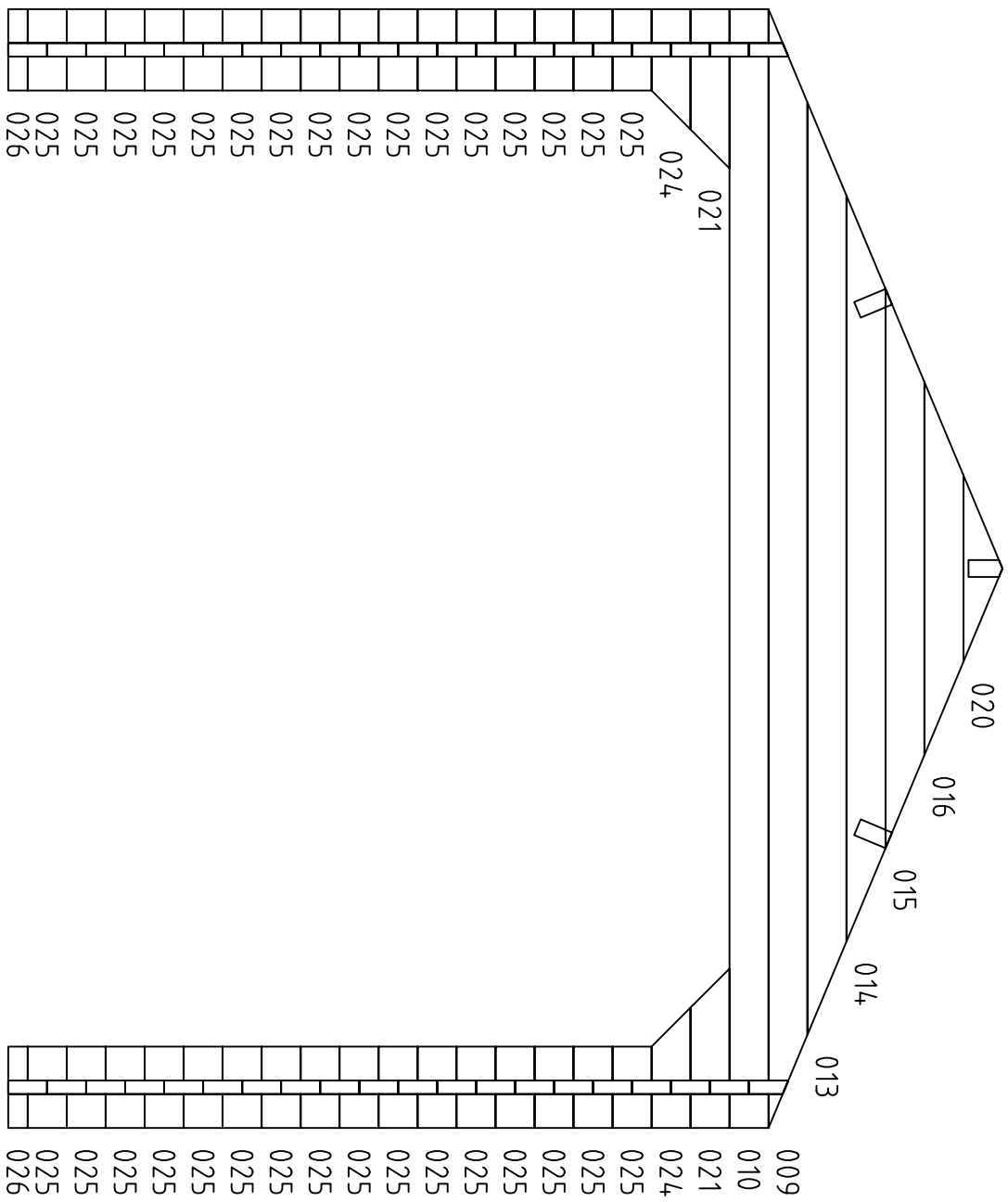

Garage 3352 / 40 / 09

B

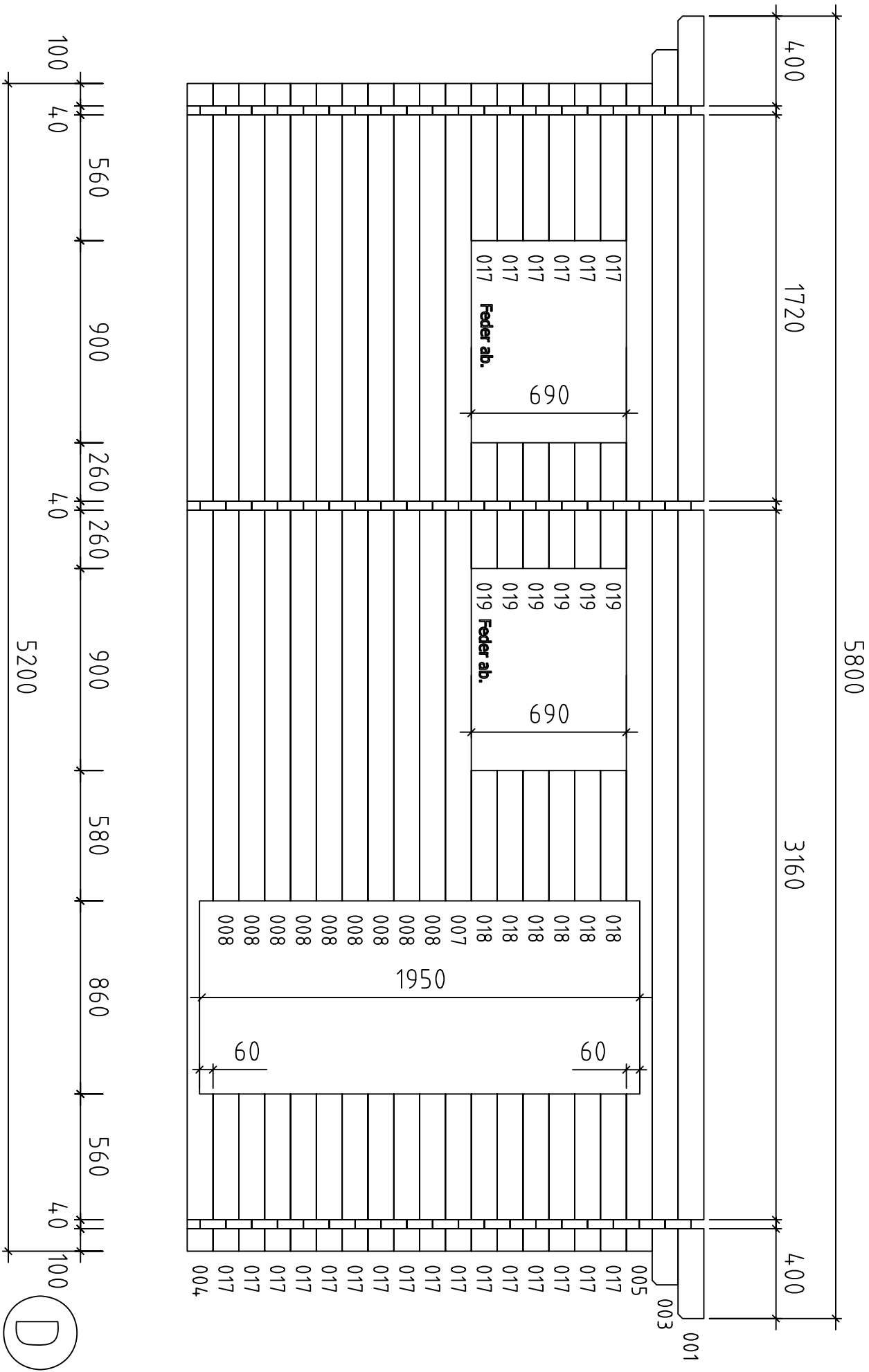



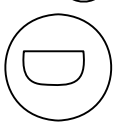

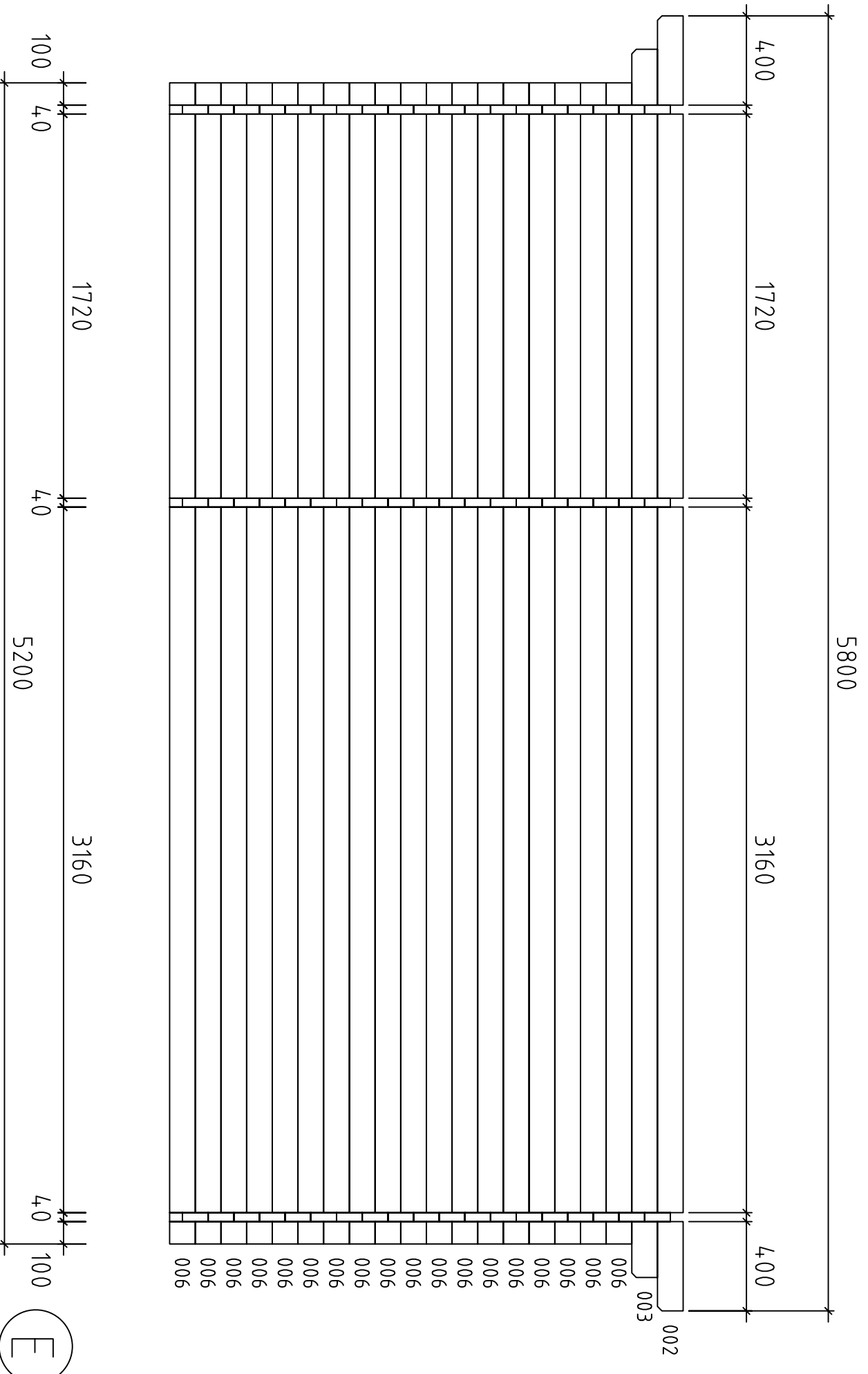



Garage 3352 / 40 / 09

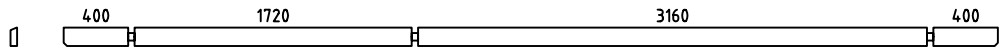
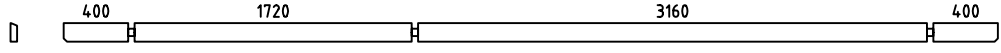
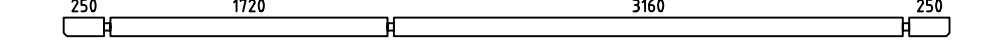
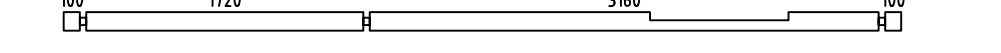
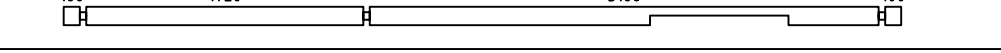
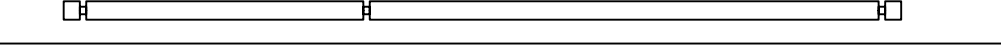
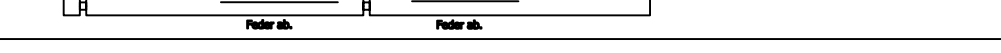
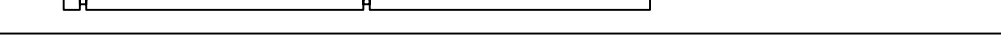
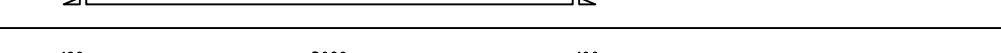
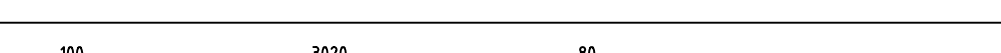
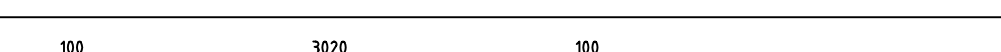
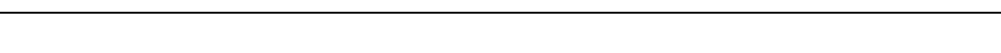
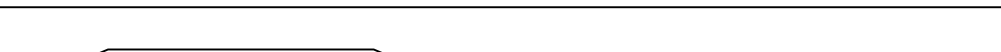
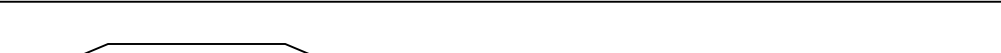

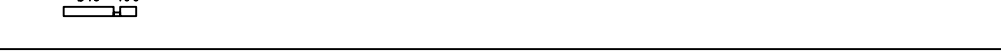
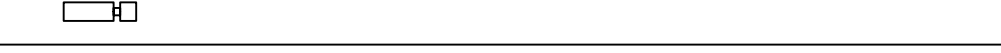
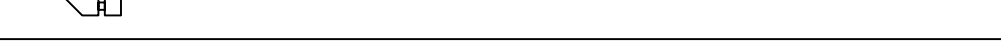

Garage 3352 / 40 / 09

E

Pos	Garage 3352 / 40 / 09	ST	F (mm)	L (mm)
001		1	40x115	5800
002		1	40x115	5800
003		2	40x115	5500
004		1	40x115	5200
005		1	40x115	5200
006		18	40x115	5200
007		1	40x115	3640
008		9	40x115	3640
009		3	40x115	3300
010		20	40x115	3300
011		1	40x115	3300
012		1	40x58	3300
013		3	40x115	2750
014		3	40x115	2200
015		3	40x115	1650
016		3	40x115	1100
017		22	40x115	700
018		6	40x115	580
019		6	40x115	560
020		3	40x115	550
021		2	40x115	470
022		2	40x58	450
023		36	40x115	450
024		2	40x115	355
025		32	40x115	240

