

**EN OWNER'S MANUAL /**

Instructions for Assembly 'Palladium High Store Locker'  
Size 5Ft x 2Ft / 1.6 m x 0.7 m (Double Door)  
Ver: 0.0

**FR MANUEL D'INSTRUCTION/**

Instructions pour l'Assemblage 'Palladium Haut Store Casier'  
Taille 5Pieds x 2Pieds / 1.6 Mètre x 0.7 Mètre (Double porte)  
Ver: 0.0

**DE Benutzerhandbuch /**

Montageanleitung 'Palladium Hoch Store Spind'  
Größe: 5Ft x 2Ft / 1.6 m x 0.7 m (Doppeltür)  
Ver: 0.0

**ES MANUAL DO PROPRIETARIO/**

Instrucciones de montaje 'Palladium Alto Almacenar Casillero'  
Tamaño 5Pies x 2Pies / 1.6 Metros x 0.7 Metros (Puerta doble)  
Ver: 0.0

**PT MANUAL DO PROPRIETARIO/**

Instruções de montagem 'Palladium Alto loja Gaveta'  
Tamanho 5pés x 2pés / 1.6 Metro x 0.7 Metro (Porta dupla)  
Ver:0.0

**NL Gebruiksaanwijzing voor eigenaar/**

Instructies voor bouw 'Palladium Hoge winkel Kastje'  
Maat 5 voet x 2 voet / 1.6 Meter x 0.7 Meter (Dubbele deur)  
Versie: 0.0

**CS Příručka uživatele /**

Návod k montáži 'Palladium velký obchod Locker'  
Velikost 5 Stopy x 2 Stopy / 1.6 Metr x 0.7 Metr (Dvojité dveře)  
Verze : 0.0

**SK NÁVOD PRE UŽÍVATEĽA /**

Návod na zloženie 'Palladium vysoký zdroj skrinka'  
Velkost' 5Stopa x 2Stopa / 1.6 m x 0.7 m (Dvojité dvere)  
Pozri: 0.0

**SL PRIROČNIK ZA LASTNIKA /**

Navodila za montažo 'Palladium visok prodajalna Locker'  
Velikost 5Čevljev x 2Čevljev / 1.6 Metrov x 0.7 Metrov (Dvojna vrata)  
Razl: 0.0

**HR Gazdinski Priručnik /**

Instrukcije za skupštine 'Palladium visok prodavaonica ormarić'  
Veličina 5 Stopalo x 2 Stopalo/ 1.6 Metar x 0.7 Metar (Dvostruka vrata)  
Ver: 0.0

**HU FELHASZNÁLÓI KÉZIKÖNYV /**

Útmutató az összeszereléshez 'Palladium magas tárolóöltözőszekrény'  
Méret 5Láb x 2Láb / 1.6 Méter x 0.7 Méter (Dupla ajtó)  
0.0 verzió

**SV ÄGARENS MANUAL/**

Monteringsinstruktioner för 'Palladium hög lagra skåp'  
Storlek 5 fot x 2 fot / 1.6 m x 0.7 m (Dubbel dörr)  
Version: 0.0

**IT MANUALE DEL PROPRIETARIO /**

Istruzioni per l'assemblaggio 'Palladium alto negozio armadietto'  
Taglia 5 Piedi x 2 Piedi / 1.6Metri x 0.7Metri (Doppia porta)  
Versione 0.0

**PL PODRĘCZNIK UŻYTKOWNIKA /**

Instrukcja montażu 'Palladium wysoko sklep szafka'  
Wymiary 5Stopy x 2Stopy / 1.6 Metr x 0.7 Metr (Podwójne drzwi)  
Wersja: 0.0

**RO MANUAL DE UTILIZARE /**

Instrucțiuni de asamblare 'Palladium ridicat stoc dulăpior'  
Mărimē 5Picioare x 2Picioare / 1.6 Metri x 0.7 Metri (Ușă dublă)  
Ver: 0.0

**BG РЪКОВОДСТВО ЗА ПРИТЕЖАТЕЛЯ /**

Инструкции за събиране 'Palladium високо магазин кабинет'  
Размер 5 Фута x 2 Фута / 1.6 Метра x 0.7 Метра (Двойни врати)  
Версия: 0.0

**TR KULLANIM KILAVUZU /**

Montaj Talimatları 'Palladium yüksek depolamak malzeme dolabı'  
Boyut 5Fit x 2Fit / 1.6 m x 0.7m (Çift kapı)  
Sürüm: 0.0

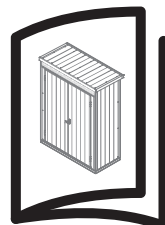
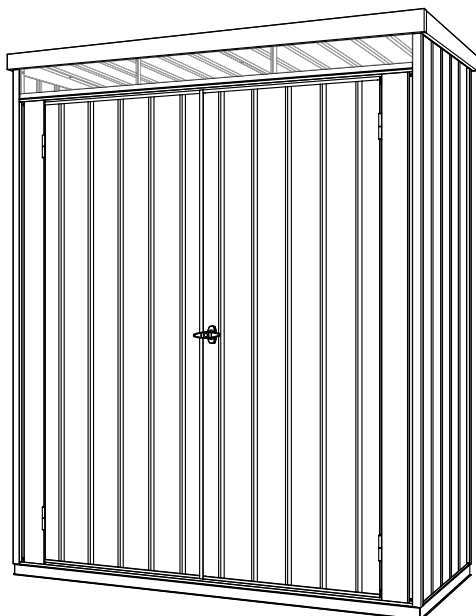

EN

### Building Dimensions :

Approximate Size	Storage		Exterior Dimension				Interior Dimension		Door Opening		
	Area	Volume	Base Dimension		Roof Edge to Edge		Wall to Wall				
			inch	cm	inch	cm	inch	cm	inch	cm	
5 Ft x 2 Ft	10 3/4 Sq. Ft	66 Cu.Ft	Width	62 1/2	158.6	63 3/8	161.1	60 3/4	154.4	50 3/8	127.9
1.6 m x 0.7 m	1.0 Sq.m	1.8 Cu.m	Depth	27 3/4	70.4	30 3/8	77	25 3/8	64.4		
			Height			82 1/8	208.7	74	188	66 7/8	169.8

Snow load tested max. 30lbs / sq.foot (As per IP Standard).

"We recommend to clear snow from the Roof top after each Snowfall."

A snow depth of more than 10 cm can become hazardous!

FR

### Dimensions du bâtiment :

Taille approximative	Stockage		Dimension extérieure				Dimension intérieure		Ouverture de porte		
	Secteur	Volume	Dimension de base		Toit de bord au bord		Mur à mur				
			pouce	cm	pouce	cm	pouce	cm	pouce	cm	
5 Pieds x 2 Pieds	10 3/4 Carré pieds	66 Pieds cube	Largeur	62 1/2	158.6	63 3/8	161.1	60 3/4	154.4	50 3/8	127.9
1.6 Mètre x 0.7 Mètre	1.0 Mètre carré	1.8 Mètre cube	Profondeur	27 3/4	70.4	30 3/8	77	25 3/8	64.4		
			Hauteur			82 1/8	208.7	74	188	66 7/8	169.8

Charge de neige testé max. 30lbs / Carré pieds (conformément à la norme IP).

"Nous recommandons d'enlever la neige du Toit après chaque Enneigement."

Une épaisseur de neige de plus de 10 cm peut devenir dangereux!

DE

### Gebäude Abmessung:

Ungefähre Größe	Speicher		Außen Abmessung				Innen Abmessung		Türöffnung		
	Bereich	Volumen	Fundament Abmessung		Dach Kante bis Kante		( von Wand zu Wand )				
			inch	cm	inch	cm	inch	cm	inch	cm	
5 Ft x 2 Ft	10 3/4 Sq. Ft	66 Cu.Ft	Breite	62 1/2	158.6	63 3/8	161.1	60 3/4	154.4	50 3/8	127.9
1.6 m x 0.7 m	1.0 Sq.m	1.8 Cu.m	Tiefe	27 3/4	70.4	30 3/8	77	25 3/8	64.4		
			Höhe			82 1/8	208.7	74	188	66 7/8	169.8

Schneelast max. getestet. 30lbs /sq.Foot (gem. Standard IP).

"Wir empfehlen, Schnee von der Dachspitze nach jedem Schneefall zu löschen."

Eine Schneetiefe von mehr als 10 cm kann gefährlich werden!

ES

### Medidas de la caseta:

El Tamaño a proximado	Área de almacenaje		Dimensión exterior				Dimensión interior		Abertura de la puerta		
	Área	Volumen	Dimensión de la base		Borde del tejado al borde		pared a pared				
			Pulgada	cm	Pulgada	cm	Pulgada	cm	Pulgada	cm	
5 Pies x 2 Pies	10 3/4 Pies cuadrados	66 Pies Cúbicos	Anchura	62 1/2	158.6	63 3/8	161.1	60 3/4	154.4	50 3/8	127.9
1.6 Metros x 0.7 Metros	1.0 Metros cuadrados	1.8 Metros Cúbicos	Profundidad	27 3/4	70.4	30 3/8	77	25 3/8	64.4		
			Altura			82 1/8	208.7	74	188	66 7/8	169.8

Carga de nieve probado max. 30lbs / Pies cuadrados (según el estándar de IP).

"Se recomienda limpiar la nieve de la azotea después de cada nevada."

Una profundidad de nieve de más de 10 cm puede llegar a ser peligrosa!

PT

### Área de Construção:

Dimensão aproximada	Área de Arrumação		Dimensão Exterior				Dimensão Interior		Abertura da Porta		
	Área	Volume	Dimensão da base		Amplitude do Telhado		(Parede a Parede)				
			Polegada	centímetro	Polegada	centímetro	Polegada	centímetro	Polegada	centímetro	
5 pés x 2 pés	10 3/4 Pies quadrado	66 Pies cúbico	Comprimento	62 1/2	158.6	63 3/8	161.1	60 3/4	154.4	50 3/8	127.9
1.6 Metro x 0.7 Metro	1.0 Metro quadrado	1.8 Metro cúbico	Profundidade	27 3/4	70.4	30 3/8	77	25 3/8	64.4		
			Altura			82 1/8	208.7	74	188	66 7/8	169.8

Carga de neve testado max. 30lbs / Pies quadrado (conforme padrão IP).

"Recomendamos limpar a neve do topo do telhado após cada queda de neve."

Uma profundidade de neve de mais de 10 cm pode tornar-se perigosa!

NL

## Gebouw afmeting:

Benadering Maat	Opslag		Buitenkant afmeting				Binnenkant afmeting		Deur opening		
	Gebied	Volume	Basis afmeting		Dakrand tot rand		Muur tot muur				
			inch		cm		inch		cm		
5 Voet x 2 Voet	10 3/4 Vierkante voet	66 Kubieke voet	Wijde	62 1/2	158.6	63 3/8	161.1	60 3/4	154.4	50 3/8	127.9
1.6 m x 0.7 m	1.0 Vierkante meter	1.8 Kubieke meter	Diepte	27 3/4	70.4	30 3/8	77	25 3/8	64.4		
			Hoogte			82 1/8	208.7	74	188	66 7/8	169.8

Sneeuw belasting getest max. 30lbs / Vierkante voet (volgens het standaard IP-).

“We raden aan sneeuw uit het dak te verwijderen na elke sneeuwval.”

Een sneeuwdiepte van meer dan 10 cm kan gevaarlijk worden!

CS

## Budova rozměr

Přibližné rozměry	Skladování		Vnější rozměr				Vnitřní rozměr		Otevírání dveří		
	Plocha	Objem	Základní rozměr		Na okraj střechy edge		zdi ke zdi				
			inch		cm		inch		cm		
5 Stopy x 2 Stopy	10 3/4 Čtver- eční Stopy	66 Krychlový Stopy	Šířka	62 1/2	158.6	63 3/8	161.1	60 3/4	154.4	50 3/8	127.9
1.6 Metr x 0.7 Metr	1.0 Čtver- eční metr	1.8 Krychlový Metr	Hloubka	27 3/4	70.4	30 3/8	77	25 3/8	64.4		
			Výška			82 1/8	208.7	74	188	66 7/8	169.8

Zkouška zatížení sněhu max. 30lbs / Čtver-  
eční Stopy (podle normy IP).

“Doporučujeme odstranit sníh ze střešního krytu po každém sněžení.”

Možná hloubka sněhu větší než 10 cm může být nebezpečná!

SK

## Stavebné rozmer

Približné veľkosti	Sklad		Vonkajší rozmer				Interiér rozmer		Otvorenie dverí		
	Priestor	Objem	Base rozmer		Strešné okraja k okraju		Zdi k múru				
			inch		cm		inch		cm		
5 Stopa x 2 Stopa	10 3/4 Stopa štvorcový	66 Stopa kubický	Šírka	62 1/2	158.6	63 3/8	161.1	60 3/4	154.4	50 3/8	127.9
1.6 m x 0.7 m	1.0 Meter štvorcový	1.8 Meter kubický	Hĺbka	27 3/4	70.4	30 3/8	77	25 3/8	64.4		
			Výška			82 1/8	208.7	74	188	66 7/8	169.8

Testovanie zaťaženia snehu max. 30lbs / Stopa štvorcový (podľa IP štandardu).

“Odporúčame odstrániť sneh zo strechy po každej snehu.”

Z hĺbky snehu väčšej ako 10 cm sa môže stať nebezpečné!

SL

## Zidanje obseg

približno velikost	Skladiščenje		zunanji obseg				notranji obseg		vrata predrtina		
	Območje	Prostornina	osnova obseg		streha rob v rob		obdati obzidati				
			cola		cm		cola		cm		
5 Čevljev x 2 Čevljev	10 3/4 Kvadrat- nih Čevljev	66 Kubičnih Čevljev	širina	62 1/2	158.6	63 3/8	161.1	60 3/4	154.4	50 3/8	127.9
1.6 Metrov x 0.7 Metrov	1.0 Kvadratnih Metrov	1.8 Kubičnih Metrov	globina	27 3/4	70.4	30 3/8	77	25 3/8	64.4		
			višina			82 1/8	208.7	74	188	66 7/8	169.8

Snow obremenitev testiran max. 30lbs / Kvadratnih Čevljev (po standardu IP).

“Priporočamo, da počistite sneg z vrha strehe po vsakem sneženju.”

Z globino snega več kot 10 cm lahko postane nevarno!

HR

## Zgrada dimenzija

Približno određena mjera	Skladištenje		Vanjski dimenzija				Interijer dimenzija		Vrata Open		
	Područje	Svezak	Temeljiti dimenzija		Krov rub to rub		Zidni to zidni		inch	cm	
			inch	cm	inch	cm	inch	cm			
5 Stopalo x 2 Stopalo	10 3/4 Četvornih Stopalo	66 Kubni Stopalo	širina	62 1/2	158.6	63 3/8	161.1	60 3/4	154.4	50 3/8	127.9
1.6 Méter x 0.7 Méter	1.0 Četvornih Méter	1.8 Kubni Méter	dubina	27 3/4	70.4	30 3/8	77	25 3/8	64.4		
			visina			82 1/8	208.7	74	188	66 7/8	169.8

Testirano opterećenje max.30lbs / Četvornih Stopalo (prema IP standardu).  
 “Preporučujemo čišćenje snijega s vrha krova nakon svakog snijega.”  
 Nema dubine snijega veće od 10 cm može biti opasna!

HU

## Építési dimenzió

Hozzávetőleges mérete	Tárolás		Külső méret				A belső dimenzió		Ajtónyitás		
	Terület	Mennyiség	Alap dimenzió		Tető élétől él		A fal és a fal		Hüvelyk	cm	
			Hüvelyk	cm	Hüvelyk	cm	Hüvelyk	cm			
5 Láb x 2 Láb	10 3/4 Négyzet Láb	66 Köb Láb	Szélesség	62 1/2	158.6	63 3/8	161.1	60 3/4	154.4	50 3/8	127.9
1.6 Méter x 0.7 Méter	1.0 Négyzet méter	1.8 Köbméter	Oldalmagasság	27 3/4	70.4	30 3/8	77	25 3/8	64.4		
			Magasság			82 1/8	208.7	74	188	66 7/8	169.8

A terhelés max. 30lbs / Négyzet Láb (IP-szabvány szerint).  
 “Javasoljuk, hogy minden hóesést követően tisztítsa meg a havat a tetőtől.”  
 A 10 cm-nél hosszabb hóvastagság veszélyessé válhat!

SV

## Byggnadsdimensioner:

Ungefärlig storlek	Lager		Yttre dimensioner				Inre dimensioner		Dörröppning		
	Area	Volym	Basdimensioner		Tak kant till kant		Vägg till vägg		Tum	cm	
			Tum	cm	Tum	cm	Tum	cm			
5 fot x 2 fot	10 3/4 kvadrat fot	66 kubik fot	Bredd	62 1/2	158.6	63 3/8	161.1	60 3/4	154.4	50 3/8	127.9
1.6 m x 0.7 m	1.0 kvadrat meter	1.8 kubik meter	Djup	27 3/4	70.4	30 3/8	77	25 3/8	64.4		
			Höjd			82 1/8	208.7	74	188	66 7/8	169.8

Snow last testas max. 30lbs / kvadrat fot (enligt IP-standard).  
 “Vi rekommenderar att klara snö från taket efter varje snöfall.”  
 Ett snödjup på mer än 10 cm kan bli farligt!

IT

## Dimensioni di Costruzione:

Dimensione approssimativa	Deposito		Dimensione Esterna				Dimensioni Interne		Apertura della Porta		
	Area	Volume	Dimensione della Base		Soffitto da Lato a Lato		Da Muro a Muro		Inches	Centimetri	
			Inches	Centimetri	Inches	Centimetri	Inches	Centimetri			
5 Piedi x 2 Piedi	10 3/4 Piedi Quadrati	66 Piedi Cubici	Ampiezza	62 1/2	158.6	63 3/8	161.1	60 3/4	154.4	50 3/8	127.9
1.6 Metri x 0.7 Metri	1.0 Metri Quadrati	1.8 Metri Cubici	Profondità	27 3/4	70.4	30 3/8	77	25 3/8	64.4		
			Altezza			82 1/8	208.7	74	188	66 7/8	169.8

Snow carico testato max. 30lbs / Piedi Quadrati (come per IP standard).  
 “We consigliamo di eliminare la neve dalla tetto del tetto dopo ogni nevicata.”  
 Una profondità di neve di oltre 10 cm può diventare pericolosa!

PL

## Wymiary budowlane:

Przybliżone wymiary	Magazynowa		Wymiary zewnętrzne				Wymiary wewnętrzne		Otwieranie drzwi		
	Powierzchnia	Kubatura	Wymiary fundamentów		Dachu od krawędzi do krawędzi		od ściany do ściany				
			Cal	cm	inch	cm	inch	cm	inch	cm	
5 Stopy x 2 Stopy	10 3/4 Stopy kwadratowy	66 Stopy sześcienny	<b>Szerokość</b>	62 1/2	158.6	63 3/8	161.1	60 3/4	154.4	50 3/8	127.9
1.6 Metr x 0.7 Metr	1.0 Metr kwadratowy	1.8 Metr sześcienny	<b>Głębokość</b>	27 3/4	70.4	30 3/8	77	25 3/8	64.4		
			<b>Wysokość</b>			82 1/8	208.7	74	188	66 7/8	169.8

Obciążenia śniegiem testowałem max.30lbs / Stopy kwadratowy(jak na IP Standard).

“Zalecamy wyczyszczenie śniegu z dachu dachu po każdym śniegu.”

Możliwość śniegu powyżej 10 cm może stać się niebezpieczna!

RO

## Cladirea dimensiuni

Dimensiunea aproximativa	Depozitarea		Dimensiunea exterioara				Dimensiunea interne		deschiderea usii		
	Suprafata	Volumul	Baza dimensiuni		Acoperisul marginea la marginea		perete in perete				
			inch	cm	inch	cm	inch	cm	inch	cm	
5 Picioare x 2 Picioare	10 3/4 Picioare pătrați	66 Picioare cubi	<b>Latimea</b>	62 1/2	158.6	63 3/8	161.1	60 3/4	154.4	50 3/8	127.9
1.6 Metri x 0.7 Metri	1.0 Metri pătrați	1.8 Metri cubi	<b>Adancimea</b>	27 3/4	70.4	30 3/8	77	25 3/8	64.4		
			<b>Inaltimea</b>			82 1/8	208.7	74	188	66 7/8	169.8

Rezultatea de încărcare maximă testată. 30lbs / Picioare pătrați (conform standardului IP).

“Vă recomandăm să eliminați zăpada din partea superioară a acoperișului după fiecare zăpadă.”

O adâncime de zăpadă mai mare de 10 cm poate deveni periculoasă!

BG

## Сградата измерение

Ориентировачна размер	Съхранение		Външно измерение				Министърът на вътрешните измерение		Вратата отваряне		
	Площ	Обем	База измерение		Покрив край до край		Стената на стената				
			Инча	Сантиметра	Инча	Сантиметра	Инча	Сантиметра	Инча	Сантиметра	
5 Фута x 2 Фута	10 3/4 Квадратни Фута	66 Кубични Фута	<b>Ширина</b>	62 1/2	158.6	63 3/8	161.1	60 3/4	154.4	50 3/8	127.9
1.6 Метра x 0.7 Метра	1.0 Квадратни Метра	1.8 Кубични Метра	<b>Дълбочина</b>	27 3/4	70.4	30 3/8	77	25 3/8	64.4		
			<b>Височина</b>			82 1/8	208.7	74	188	66 7/8	169.8

Тестване на тежестта на снемане макс. 30lbs / Квадратни Фута (според IP Стандарт).

“След всеки снеговалеж препоръчваме да изчистите снега от покрива на покрива.”

Дълбочина на снега повече от 10 см може да стане опасна!

TR

## İnşaat boyutu

Tahmini büyüklüğü	Depo		Dış boyutlar				İç boyutu		Kapı açılması		
	Alan	Hacim	Temel boyutundaki		sertliği için harekete		Duvardan duvara				
			İnç	Santimetre	İnç	Santimetre	İnç	Santimetre	İnç	Santimetre	
5 Fit x 2 Fit	10 3/4 Metre Fit	66 Kübik Fit	<b>Genişlik</b>	62 1/2	158.6	63 3/8	161.1	60 3/4	154.4	50 3/8	127.9
1.6 m x 0.7 m	1.0 Metrekare	1.8 Kübik metre	<b>Derinlik</b>	27 3/4	70.4	30 3/8	77	25 3/8	64.4		
			<b>Yükseklik</b>			82 1/8	208.7	74	188	66 7/8	169.8

Saat yükü test max. 30lbs / Metre Fit (IP Standardına göre).

“Her Kar yağışı sonrasında Çatı üstten kar temizlemenizi öneririz.”

Kar derinliği 10 cm'den fazla tehlikeli olabilir!

**EN Tools You Will Need**

- |                                  |                        |
|----------------------------------|------------------------|
| 1. Cordless Drill - Philips Head | 6. Tape Measure        |
| 2. Screwdriver                   | 7. Hand Gloves         |
| 3. Carpenters Square             | 8. Eye Protector       |
| 4. 8' Step Ladder                | 9. Box Spanner-8 mm    |
| 5. Level - 3ft.                  | 10. Adjustable Spanner |

**FR Outils dont vous aurez besoin**

- |                                     |                                |
|-------------------------------------|--------------------------------|
| 1. Perceuse sans fil – Tête Philips | 6. Ruban à mesurer             |
| 2. Tournevis                        | 7. Gants                       |
| 3. Équerre du Menuisier             | 8. Protecteur des Yeux         |
| 4. Escabeau 8'                      | 9. Clé de serrage de boîte-8mm |
| 5. Niveau - 3ft.                    | 10. Clé à molette              |

**DE Benötigte Werkzeuge**

- |   |                                      |
|---|--------------------------------------|
| 1. Akku-Bohrschrauber - Kreuzschlitzbit | 6. Maßband                           |
| 2. Kreuzschlitz                         | 7. Handschuhe                        |
| 3. Winkelmaß                            | 8. Schutzbrille                      |
| 4. 8' Leiter                            | 9. Kasten-Schraubenschlüssel-8mm     |
| 5. Wasserwaage – 1 m                    | 10. Verstellbarer Schraubenschlüssel |

**ES Herramientas necesarias para el montaje**

- |  |                                |
|--|--------------------------------|
| 1. Atornillador eléctrico con cabeza estrella- | 6. Cinta métrica               |
| 2. Destornillador estrella / Philips           | 7. Use guantes de seguridad    |
| 3. Gafas protectoras                           | 8. Escuadra                    |
| 4. Escalera de 8 peldaños                      | 9. Llave de tuerca de caja-8mm |
| 5. Nivel de 1m                                 | 10. Llave inglesa              |

**PT Ferramentas que irá precisar**

- |                            |                                   |
|----------------------------|-----------------------------------|
| 1. Cordless Berbequim      | 6. Fita Métrica                   |
| 2. Chave de fenda          | 7. Luvas                          |
| 3. Esquadro de carpinteiro | 8. Protector Ocular               |
| 4. Escadote 8"             | 9. Chave de parafuso de caixa-8mm |
| 5. 3ft. Nivel              | 10. Chave inglesa ajustavel       |

**NL Gereedschappen die u nodig zult hebben**

- |   |                             |
|---|-----------------------------|
| 1. Snoerloze boormachine met gekruiste kop      | 6. Meetlint                 |
| 2. Snoerloze schroevendraaier met gekruiste kop | 7. Handschoenen             |
| 3. Winkelhaak                                   | 8. Oogbescherming           |
| 4. Ladder met acht treden                       | 9. Vak spanner-8mm          |
| 5. Waterpas                                     | 10. Verstelbare moersleutel |

**CS Budete potřebovat toto nářadí**

- |                                 |                          |
|---------------------------------|--------------------------|
| 1. Bezdrátová vrtačka - Philips | 6. Svinovací metr        |
| 2. Vrták                        | 7. Rukavice              |
| 3. Tesařské náměstí             | 8. Ochranné brýle        |
| 4. 8mí stupňový žebřík          | 9. Krabicový klíč - 8 mm |
| 5. Vodováha - 3ft.              | 10. Nastavitelný klíč    |

**SK Nástroje, ktoré budete potrebovať**

- |                                      |                       |
|--------------------------------------|-----------------------|
| 1. Bezdrôtová vrtačku - Philips Head | 6. Meter              |
| 2. Šraubovák                         | 7. Rukavice           |
| 3. Stolársky meter                   | 8. Ochranu na oči     |
| 4. 8' Rebrík                         | 9. Kľúčový klúč 8 mm  |
| 5. Zdvihák – 3 stopy.                | 10. Nastaviteľný klúč |

**SL Orodje, ki ga boste potrebovali**

- |                                    |                        |
|------------------------------------|------------------------|
| 1. Brezžična vrtalna- glava Philip | 6. Merilni trak        |
| 2. Vijačnik                        | 7. Rokavice            |
| 3. Mizarski kvadrat                | 8. zaščitna očala      |
| 4. 2438,4 mm dvokraka lestev       | 9. Polje kluč-8 mm     |
| 5. Nivelirka - 0,91 m              | 10. Nastavljiv Spanner |

**HR Alati, Trebat će Vam**

- |                                      |                              |
|--------------------------------------|------------------------------|
| 1. Bežični Svrdlo – Philips Voditelj | 6. Traka Divizor             |
| 2. Vijak Vozač                       | 7. Ručni Rukavice            |
| 3. Drvodjelac Četverokut             | 8. Oko Zaštitnik             |
| 4. 8' Korak Ljestve                  | 9. Kutija za ključeve - 8 mm |
| 5. Razina – 3 stoplo.                | 10. Podesivi kluč            |

**HU A szükséges szerszámok**

- |                                       |                           |
|---------------------------------------|---------------------------|
| 1. Vezeték nélküli fúró – csillagfejű | 6. Mérőszalag             |
| 2. Csavarhúzó                         | 7. Kesztyűk               |
| 3. Ácsderékszög                       | 8. Szemvédő               |
| 4. 8-fokú létra                       | 9. Csőkulcs-8 mm          |
| 5. Vízszintmérő.                      | 10. Állítható csavarkulcs |

**SV Verktyg du kommer att behöva**

- |                                      |                        |
|--------------------------------------|------------------------|
| 1. Sladdlös bormaskin - Philips borr | 6. Måttband            |
| 2. Skruvmejsel                       | 7. Verktygshandskar    |
| 3. Vinkelhake                        | 8. Ögonskydd           |
| 4. 8-fots stege                      | 9. Box skiftnyckel-8mm |
| 5. vattenmått - 3fot.                | 10. Skiftnyckel        |

**IT Gli Attrezzi di cui Avrai Bisogno**

- |  |                             |
|--|-----------------------------|
| 1. Trapano senza fili – Punta a stella | 6. Metro a Nastro           |
| 2. Cacciavite                          | 7. Guanti                   |
| 3. Squadra metallica                   | 8. Protezione per gli occhi |
| 4. Scala ad 8 pioli                    | 9. Chiave a tubo - 8mm      |
| 5. Livello – 3 piedi                   | 10. Chiave Inglese          |

**PL Potrzebne narzędzia**

- |   |                      |
|---|----------------------|
| 1. Bezprzewodowa wkrętarka – krzyżakowa | 6. Taśma miernicza   |
| 2. Śrubokręt krzyżakowy                 | 7. Rękawice ochronne |
| 3. Kałownik stolarski                   | 8. Okulary ochronne  |
| 4. 8' Drabina składana                  | 9. Klucz-Box 8mm     |
| 5. Poziomica – 91,4 cm                  | 10. Klucz nastawny   |

**RO Instrumentele de care aveți nevoie**

- |                                     |                          |
|-------------------------------------|--------------------------|
| 1. Șurubelniță – cap Philips        | 6. Ruletă de măsurat     |
| 2. Mașină de găurit                 | 7. Mănuși de protecție   |
| 3. Echer de dulgherie               | 8. Protecție pentru ochi |
| 4. Scară cu trepte de 8' (20.32 cm) | 9. Caseta Spanner-8mm    |
| 5. Nivel - 3ft.                     | 10. Cheie reglabilă      |

**BG Инструменти, които ще ви трябват**

- |   |                            |
|---|----------------------------|
| 1. Безжична бормашина - с глава Philips | 6. Рулетка                 |
| 2. Отвертка                             | 7. Ръкавици                |
| 3. Прав ъгъл                            | 8. Маска за очите          |
| 4. Стълба – 20 см (8')                  | 9. Гаечная коробка-8mm     |
| 5. Нивелир – 1 м (3ft).                 | 10. Регулируем гаечен ключ |

**TR İhtiyaç duyacağınız aletler**

- |                                    |                           |
|------------------------------------|---------------------------|
| 1. Kablosuz Matkap- Philips Başlık | 6. Mezura                 |
| 2. Tornavida                       | 7. Eldiven                |
| 3. Marangoz gönyesi                | 8. Göz Koruyucu           |
| 4. 8 Basamaklı Merdiven            | 9. Geçme Anahtar – 8mm    |
| 5. Seviye- 91,5 cm.                | 10. Ayarlanabilir Anahtar |

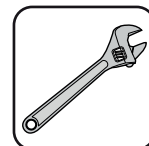

10

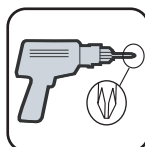

1

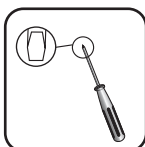

2



3



4

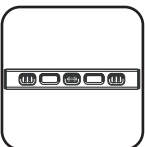

5

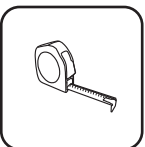

6



7



8

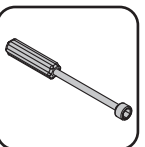

9

**EN** Parts List

**FR** Liste des pièces

**DE** Teileliste

**ES** Listado de piezas

**PT** Lista de Peças

**NL** Onderdelenlijst

**CS** Seznam součástí

**SK** Zoznam častí

**SL** Seznam delov

**HR** Dijelovi Lists

**HU** Alkatrésztlista

**SV** Komponentlista

**IT** Lista delle varie parti

**PL** Lista części

**RO** Lista elementelor componente

**BG** Списък на частите

**TR** Parça Listesi

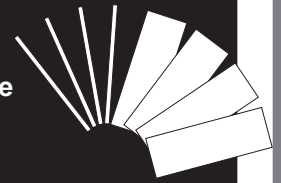

- EN** 1. Check all parts prior to installation.  
2. Before starting installation, please refer Safety & Precautions.

- FR** 1. Vérifier toutes les pièces avant l'installation.  
2. Avant de commencer l'installation, référez-vous svp à Sécurité et Précautions.

- DE** 1. Prüfen Sie alle Teile vor der Montage.  
2. Lesen Sie vor dem Aufbau die Sicherheitsanweisungen.

- ES** 1. Verifique todo el despiece antes del montaje.  
2. Antes de comenzar el montaje, consulte el apartado de seguridad y precauciones.

- PT** 1. Confirme todas as peças antes da instalação.  
2. Antes de iniciar a instalação, cheque item "Segurança e Cuidados".

- NL** 1. Controleer vooraf of alle onderdelen aanwezig zijn.  
2. Voordat u begint met installeren, verwijzing naar veiligheid voorschriften.

- CS** 1. Něž začnete s montáží, zkontrolujte všechny součásti.  
2. Před montáží si prosím přečtěte Bezpečnost a bezpečnostní opatření.

- SK** 1. Skontrolujte všetky časti pred inštaláciou.  
2. Skôr ako začnete s inštaláciou, prečítajte si Bezpečnosť a bezpečnostné opatrenia.

- SL** 1. Pred montažo preverite vse dele.  
2. Pred začetkom namestitve, glejte VARNOST & VARNOSTNI UKREPI.

- HR** 1. Provjera svih dijelova prije instalacije.  
2. Prije nego Vi počete instalacija, molim vas pogledajte Sigurnost i mjere opreza

- HU** 1. Ellenőrizzen minden alkatrészt az összeszerelés megkezdése előtt.  
2. Az összeszerelés megkezdése előtt kérjük vegye figyelembe a biztonsági utasításokat.

- SV** 1. Kolla alla delar före installationen.  
2. innan man startar installationen ska man läsa igenom säkerhet & försiktighetsåtgärder.

- IT** 1. Controlla tutte le parti prima dell'installazione.  
2. Prima di incominciare con l'installazione, per favore leggi attentamente I punti illustrati nel paragrafo Sicurezza ed Installazione.

- PL** 1. Sprawdź wszystkie części zanim przystąpisz do montażu.  
2. Przed rozpoczęciem instalacji należy przeczytać rozdział Bezpieczeństwo i środki ostrożności.

- RO** 1. Verificați toate părțile componente înainte de instalare.  
2. Înainte de a începe asamblarea, consultați capitolul. Măsuri de siguranță și protecție.

- BG** 1. Проверете всички части преди монтажа.  
2. Преди започване на монтажа, моля разгледайте Безопасност и Защита.

- TR** 1. Kurulumdan önce tüm parçaları kontrol ediniz.  
2. Montaja başlamadan önce lütfen Güvenlik ve Önlemler kısmına bakınız.



	Q001	1
	Q034	1
	P002	2
	P003	2
	Q002	1
	Q033	1
	P005	2
	Q003	1
	Q004	1
	P008	2
	Q005	1
	Q006	1
	Q007	1
	Q008	1
	Q009	1
	P014	2
	P015	2
	Q010	1
	P017	1
	P018	1
	Q011	1
	Q050	1
	P051	1
	P052	1
	Q051	1
	P025	2
	A030	2
	Q031	1
	Q032	1

	A037	2
	P026	2
	Q052	2
	Q016	1
	Q017	1
	Q028	1
	Q029	1

	DLT	1
	C22M	2
	TB	2
	A044	2
	A045	2
	C002	2
	C004	4
	C006	2
	A048	1
	A049	1
	A050	1
	A053	1Slabs
	A054	55
	A055	19
	F1	10
	S2	58
	S8	10





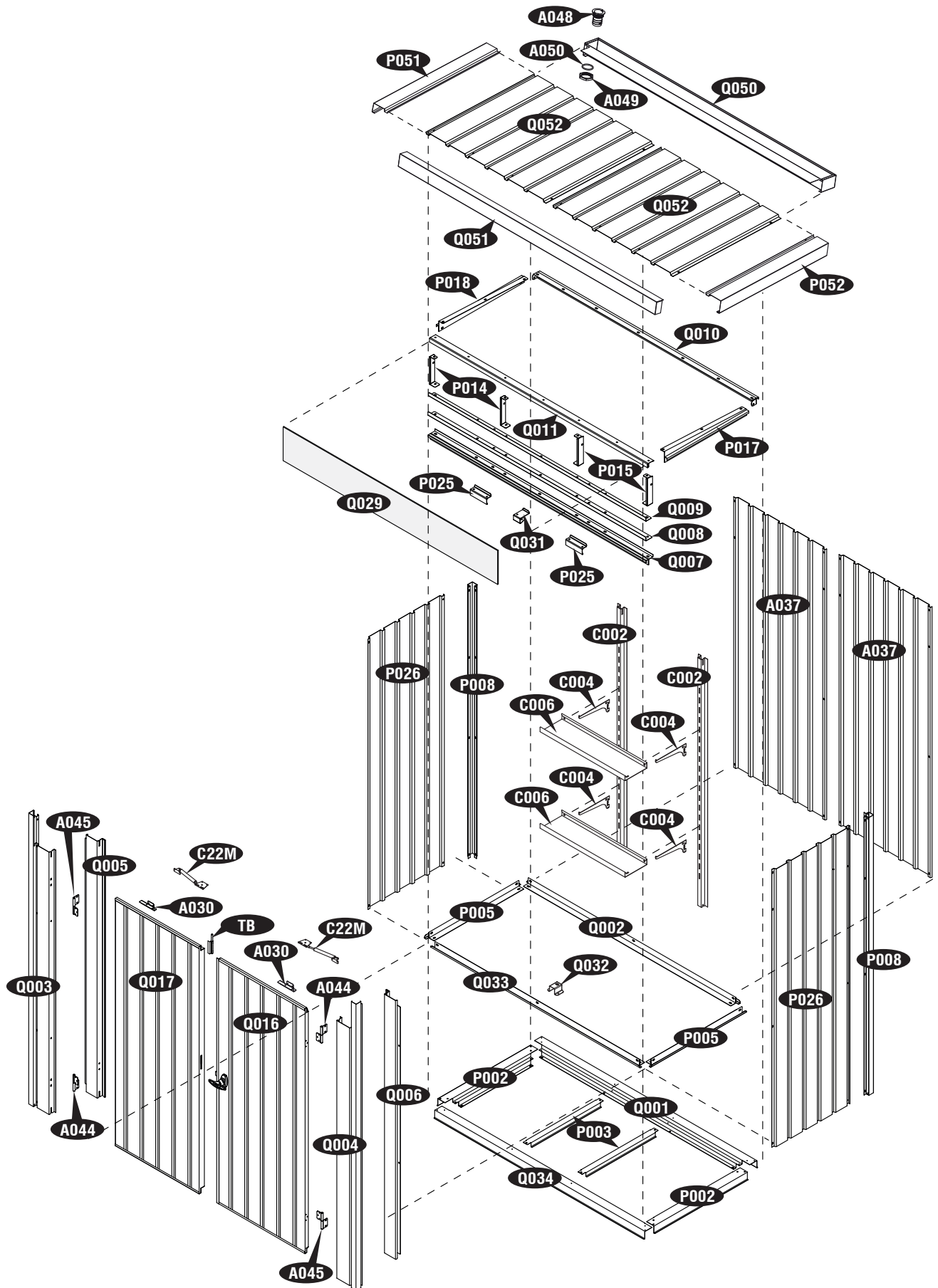

- 1 → # 11-12
- 2 → # 13-14
- 3 → # 15-24
- 4 → # 25-28
- 5 → # 29-38
- 6 → # 39-42

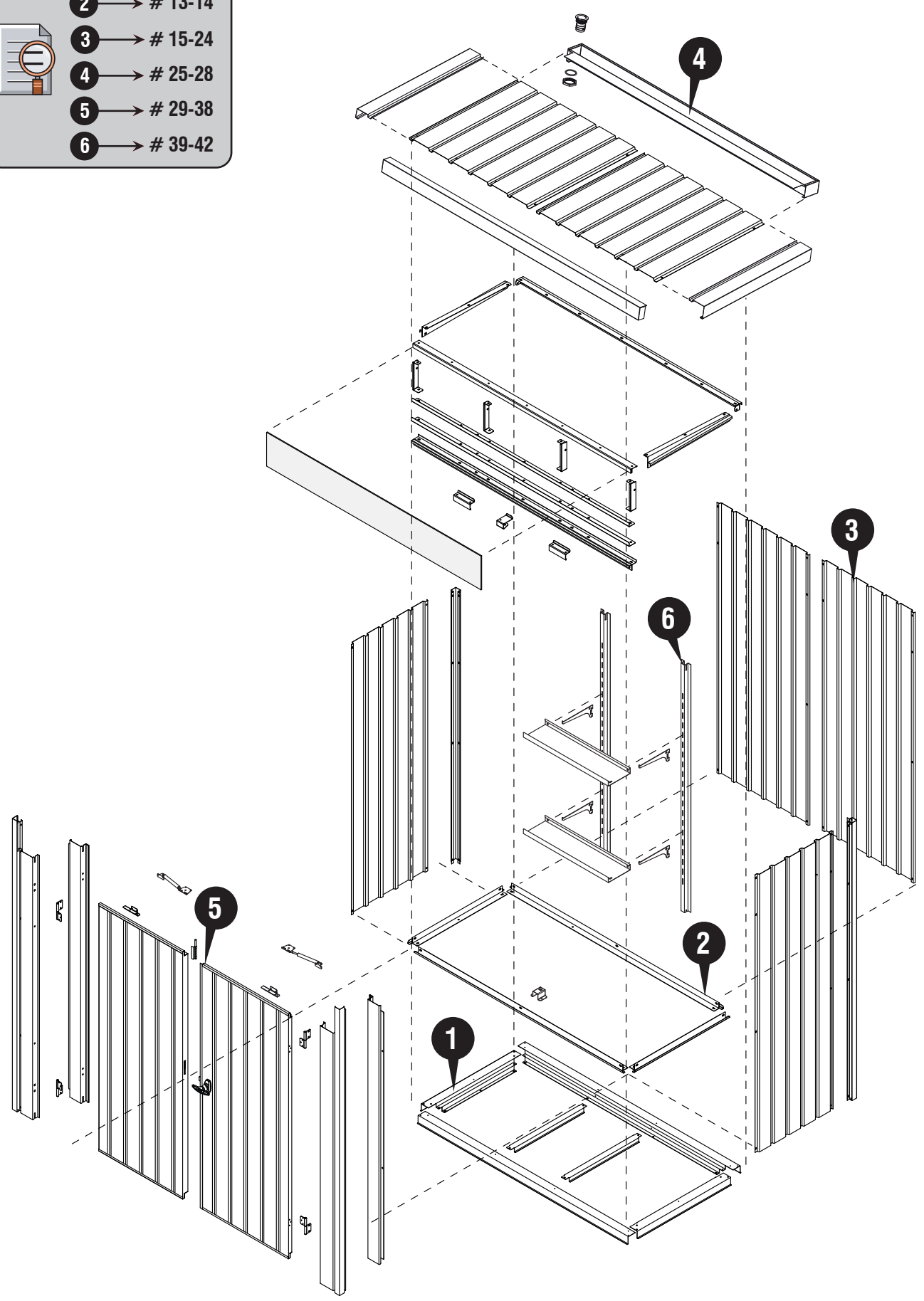

- EN** 1. Set the Torque limit of your Screw drill to #3 or #4 to ensure the Screws do not strip the Metal reinforcements.  
2. It is important that these instructions are followed step by step.  
3. Don't install under windy conditions.  
4. All panels are clearly marked and care should be taken to use the correct one.
- FR** 1. Réglez la limite de couple de votre perceuse Vis à n° 3 ou n° 4 pour s'assurer que les vis ne suppriment pas les renforts métalliques.  
2. Il est important que ces instructions soient suivies pas à pas.  
3. Ne pas installer sous conditions de vent.  
4. Toutes les parois sont clairement identifiées et il faut veiller à utiliser la bonne.
- DE** 1. Stellen Sie die Torque Limit Ihrer Schraube Bohrer # 3 oder # 4, um die Schrauben sicher nicht stripfen die Metallverstärkungen.  
2. Diese Anleitung muss unbedingt Schritt für Schritt befolgt werden.  
3. Die Montage nicht bei windigem Wetter vornehmen.  
4. Alle Platten sind deutlich gekennzeichnet, und es sind unbedingt jeweils die richtigen Platte zu verwenden.
- ES** 1. Establecer el límite de par de su taladro tornillo de # 3 y # 4 para asegurar los tornillos no tira los refuerzos metálicos.  
2. es importante que estas instrucciones se sigan paso a paso.  
3. No instale en días de mucho viento.  
4. Todos los paneles están claramente señalizados y asegúrese de seleccionar el correcto en cada momento del montaje.
- PT** 1. Defina o limite de Torque de sua broca parafuso para # 3 ou # 4 para garantir que os parafusos não tira os reforços de metal.  
2. É importante que estas instruções sejam seguidas passo a passo.  
3. Não instale sob condições com forças ventanosas.  
4. Todos os painéis estão claramente marcados, um cuidado deve ser tomado para o uso correcto.
- NL** 1. Stel de Torque limiet van uw Schroef boormachine op # 3 en # 4 om de schroeven zorgen niet strip de Metal versterkingen.  
2. Het is belangrijk dat volgende instructies stap voor stap worden gerespecteerd.  
3. Nooit de schuur installeren onder winderige omstandigheden.  
4. Markeer alle panelen zorgvuldig en gebruik altijd de juiste panelen.
- CS** 1. Nastavte mezní hodnotu točivého momentu vrtacího vrtáku na #3 nebo #4, abyste zajistili, že šrouby neztáhnou kovové výztuhy.  
2. Je důležité aby jste tento návod sledovali krok za krokem.  
3. Nemontujte při větrném počasí.  
4. Každý panel je označen a musíte dávat pozor zda používáte ten správný.
- SK** 1. Nastavte limit krútiaceho momentu vrtacieho vrtáka na #3 alebo #4, aby ste zaistili, že skrutky nezaberajú kovové výstuhy.  
2. Je nutné dodržiavať tieto inštrukcie krok za krokom.  
3. Neinštalujte za veterných podmienok.  
4. Všetky panely sú jasne označené a pozorne si treba vybrať ten správny.
- SL** 1. Za omejitev vrtilnega momenta vijaknega vijaka nastavite #3 ali #4, da zagotovite, da vijaki ne ojačitijo kovinskih ojačitev.  
2. Pomembno je, da sledite opisanim navodilom korak za korakom.  
3. Montaže ne izvijajte, kadar piha močén veter.  
4. Vse plošče so jasno označene. Paziti je treba, da vzamete vsakokrat pravilno ploščo.
- HR** 1. Postavite granicu zakretnog momenta Vašeg vijčanog bušilica na #3 ili #4 kako biste osigurali da vijci ne skidaju metalna pojačanja.  
2. To je važno da ovih instrukcije su slijedili korak po korak.  
3. Nemojte instalirati pod vjetrovitim uvjetima.  
4. Svi paneli su jasno označene i brigu treba poduzeti kako bi se koristiti ispravan panel
- HU** 1. Állítsa a csavarhúzó nyomatékhatárait #3 vagy #4-re, hogy a csavarok ne csavarják le a fém vasalatókat  
2. Fontos, hogy az itt következő instrukciókat lépésről lépésre betartsa.  
3. Szeles időben ne végezzen összeszerelést.  
4. Minden panel egyértelműen meg van jelölve, ügyeljen arra, hogy a megfelelőt használja.
- SV** 1. Ställ in momentskruvnen på din skruvborr till #3 eller #4 för att säkerställa att skruvarna inte slår av metallförstärkningarna.  
2. Det är viktigt att dessa instruktioner följs steg för steg.  
3. Installera inte när det är blåsigt.  
4. Alla paneler är tydligt markerade och försiktighet bör vidtas för att använda rätt.
- IT** 1. Impostare il limite di coppia della fresa a vite a #3 o #4 per assicurare che le viti non striscia i rinforzi metallici  
2. E' molto importante che queste istruzioni vengano seguite passo dopo passo.  
3. Non installare in presenza di forte vento.  
4. Tutti i pannelli sono chiaramente contrassegnati e bisogna fare attenzione a usare quello corretto.
- PL** 1. Zestaw limit momentu obrotowego twój śruby wiercenia do # 3 lub # 4, aby upewnić się, że śruby nie taśmy wzmocnień  
2. Bardzo ważne jest, by dokładnie stosować się do niniejszej instrukcji.  
3. Nie należy montować w przypadku silnego wiatru.  
4. Wszystkie panele ściennie są dokładnie oznakowane i należy zwrócić uwagę, aby używać właściwych elementów.
- RO** 1. Setati limita de cuplu a burghiului dvs. de șurub la #3 sau #4 pentru a vă asigura că șuruburile nu lărgește armăturile metalice.  
2. Este importantă respectarea pas cu pas a acestor instrucțiuni.  
3. Nu instalați dacă vântul atinge viteze mari.  
4. Toate panourile sunt clar marcate și trebuie avut grijă să se folosească cel corect.
- BG** 1. Нагласете границата на въртящия момент на винтовата витла до #3 или #4, за да се уверите, че винтовете не изрязват металните подсилвания.  
2. Важно е да следвате инструкциите стъпка по стъпка.  
3. Да не се монтира при ветровито време.  
4. Всички панели са ясно маркирани и трябва да се внимава за правилното използване на всеки от тях.
- TR** 1. Vidaların Metal takviyeleri soymadığından emin olmak için Vidalı matkabınızın Moment sınırını #3 veya #4'e ayarlayın.  
2. Talimatların sırasıyla uygulanması önemlidir.  
3. Rüzgarlı havalarda kurmayınız.  
4. Bütün paneller dikkatlice işaretlenmeli ve doğru olanın kullanıldığına dikkat edilmelidir.





- 1**
- |                   |            |               |
|-------------------|------------|---------------|
| EN Foundation     | CS Základy | IT Fondamenta |
| FR Fondation      | SK Základ  | PL Podstawa   |
| DE Fundament      | SL Temelj  | RO Fundația   |
| ES La cimentación | HR Temelj  | BG Фундамент  |
| PT Fundação       | HU Alap    | TR Temel      |
| NL Fundering      | SV Grunden |               |



- |                       |                                   |                                   |
|-----------------------|-----------------------------------|-----------------------------------|
| EN Parts needed       | CS Potřebné součásti              | IT Parti occorrenti               |
| FR Pièces nécessaires | SK Potřebné části                 | PL Niezbędne elementy             |
| DE Benötigte Teile    | SL Dele, ki jih boste potrebovali | RO Elementele componente necesare |
| ES Piezas necesitadas | HR Dijelovi potreban              | BG Необходими части               |
| PT Peças Necessárias  | HU Szükséges részek               | TR Gerekli parçalar               |
| NL Onderdelen nodig   | SV Delar som behövs               |                                   |

Q001	1
Q034	1
P002	2
P003	2
S2	12

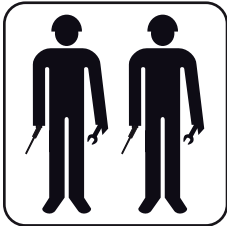

- EN Two people needed.  
 FR Deux personnes nécessaires.  
 DE Zwei Personen benötigt.  
 ES Dos personas son necesarias para el montaje  
 PT Duas pessoas necessárias.  
 NL Er zijn twee mensen nodig.  
 CS Dva lidé potřebovali.  
 SK Dvaja ľudia potrebovali.  
 SL Potrebovali sta dve osebi.  
 HR Potrebne su dvije osobe.  
 HU Két emberre volt szükség.  
 SV Två personer behövde.  
 IT Sono necessarie due persone.  
 PL Potrzebne są dwie osoby.  
 RO Au nevoie de doi oameni.  
 BG Нужни са двама души.  
 TR İki kişiye ihtiyaç vardı.

1

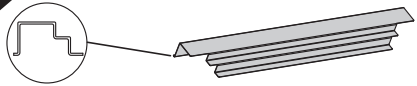

Q001 (x1)  
Q034 (x1)  
P002 (x2)

S2 (x8)

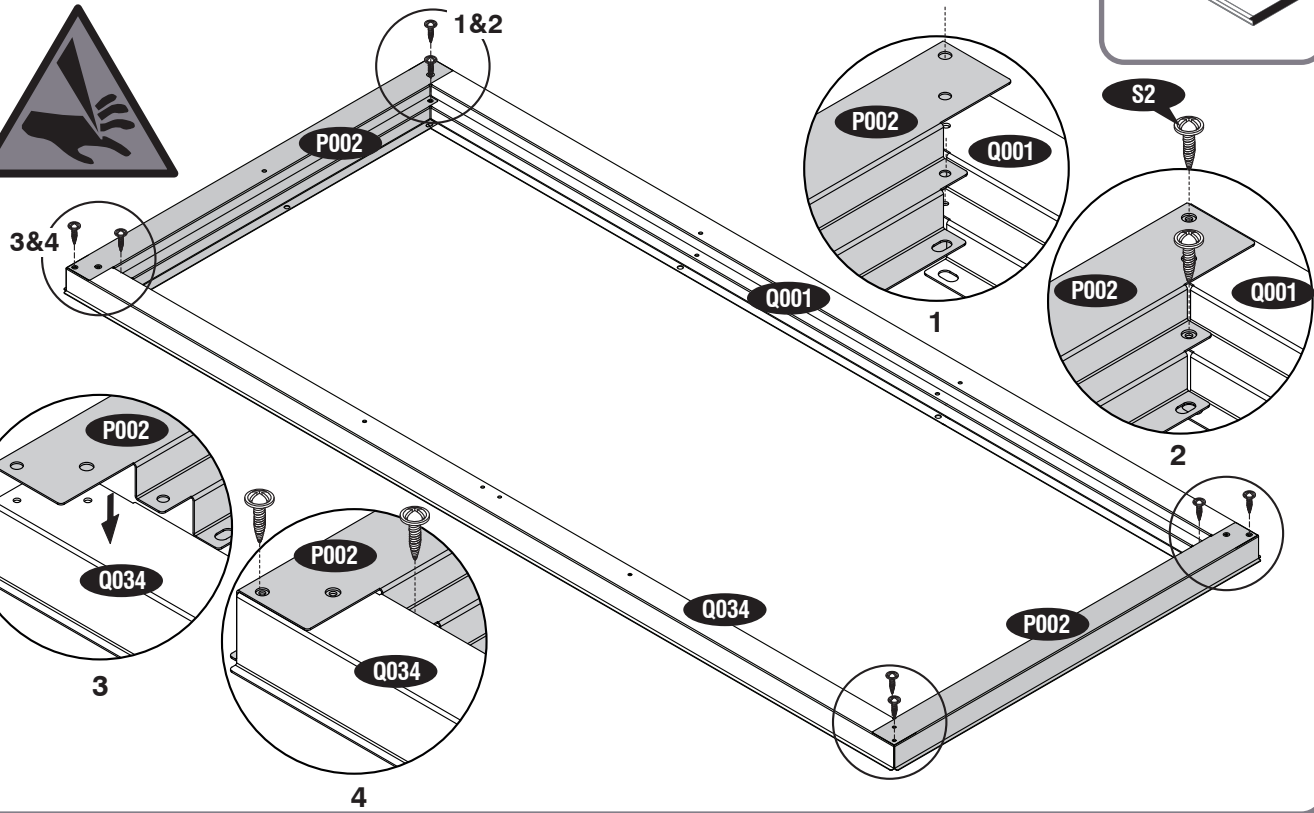
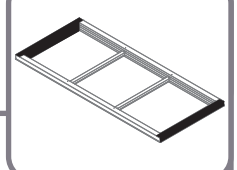

2

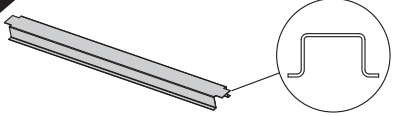

P003 (x2)

S2 (x4)

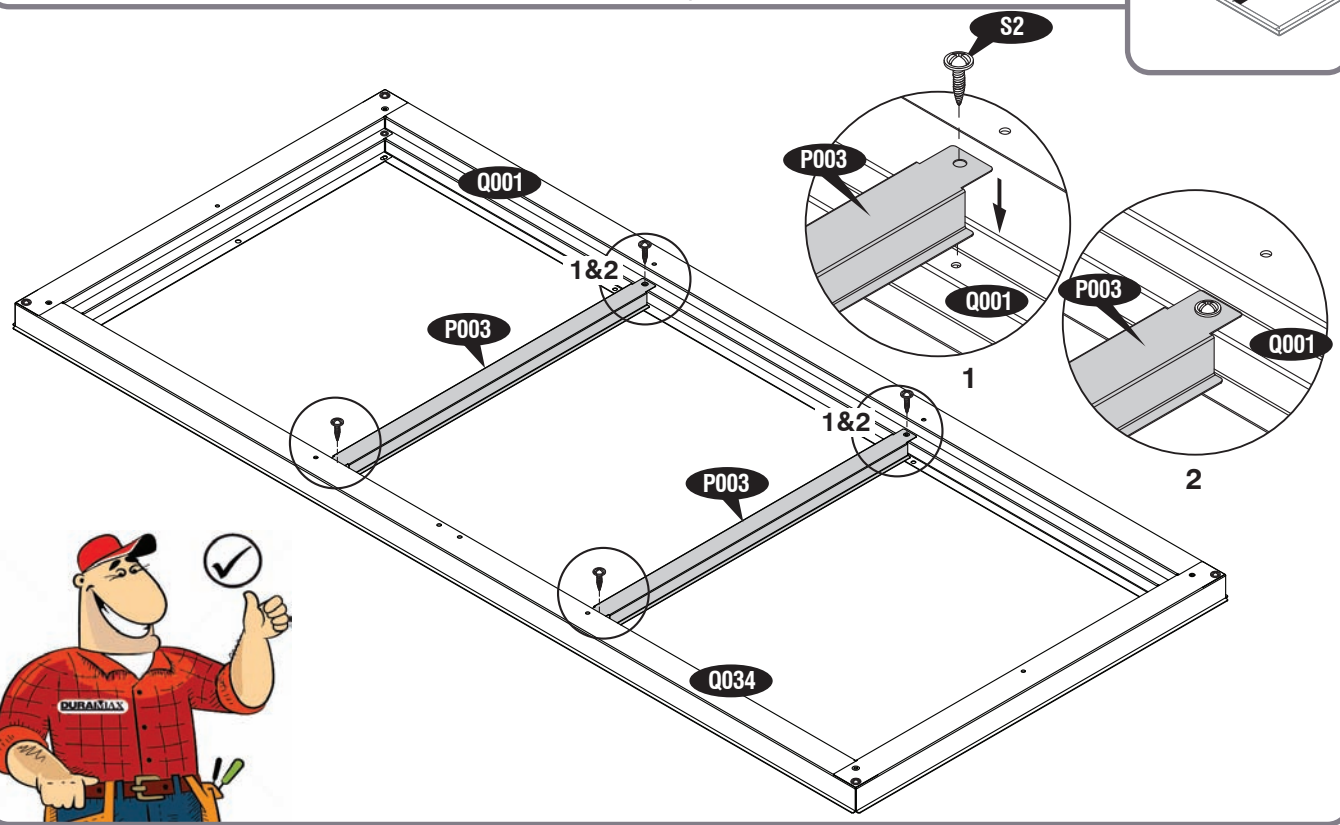
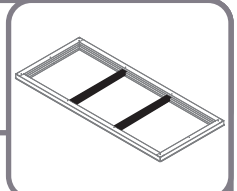



- 2**
- EN Base Frame
  - CS Základní kostra
  - IT Cornice di Base
  - FR Canaux de base
  - SK Základňový rám
  - PL Rama fundamentowa
  - DE Bodenrahmen
  - SL Osnovni okvir
  - RO Rama bazei
  - ES Armazón de la base
  - HR Baza okvir
  - BG Основна Рама
  - PT Base de armação
  - HU Alapváz
  - TR Temel Çerçevesi
  - NL Basis frame
  - SV Basram

- EN Parts needed
- CS Potřebné součásti
- IT Parti occorrenti
- FR Pièces nécessaires
- SK Potřebné časti
- PL Niezbędne elementy
- DE Benötigte Teile
- SL Dele, ki jih boste potrebovali
- RO Elementele componente necesare
- ES Piezas necesitadas
- HR Dijelovi potreban
- BG Необходими части
- PT Peças Necessárias
- HU Szükséges részek
- TR Gerekli parçalar
- NL Onderdelen nodig
- SV Delar som behövs

Q002	1
Q033	1
P005	2
S2	10

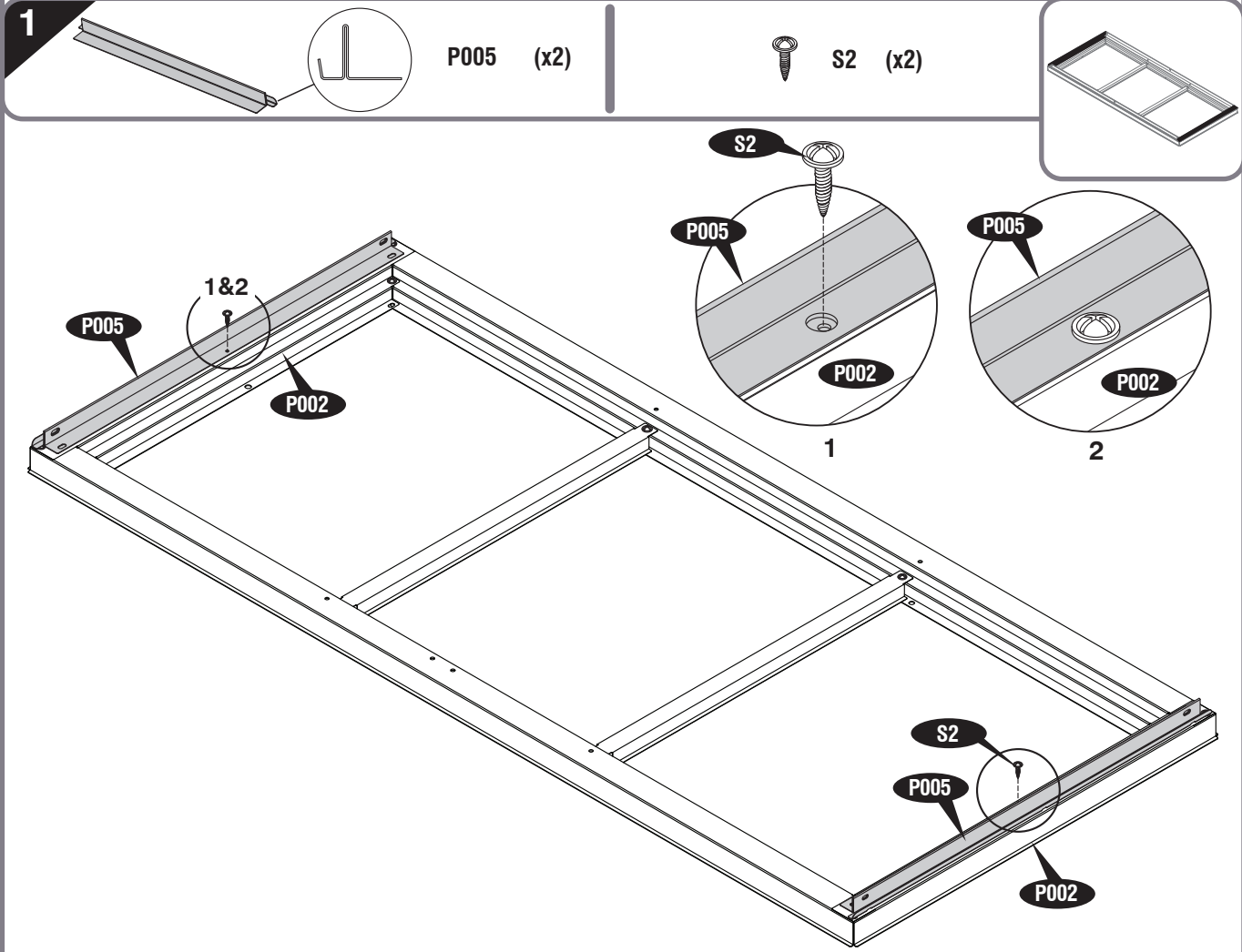

2

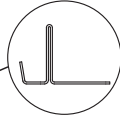
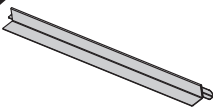

Q002 (x1)  
Q033 (x1)



S2 (x8)

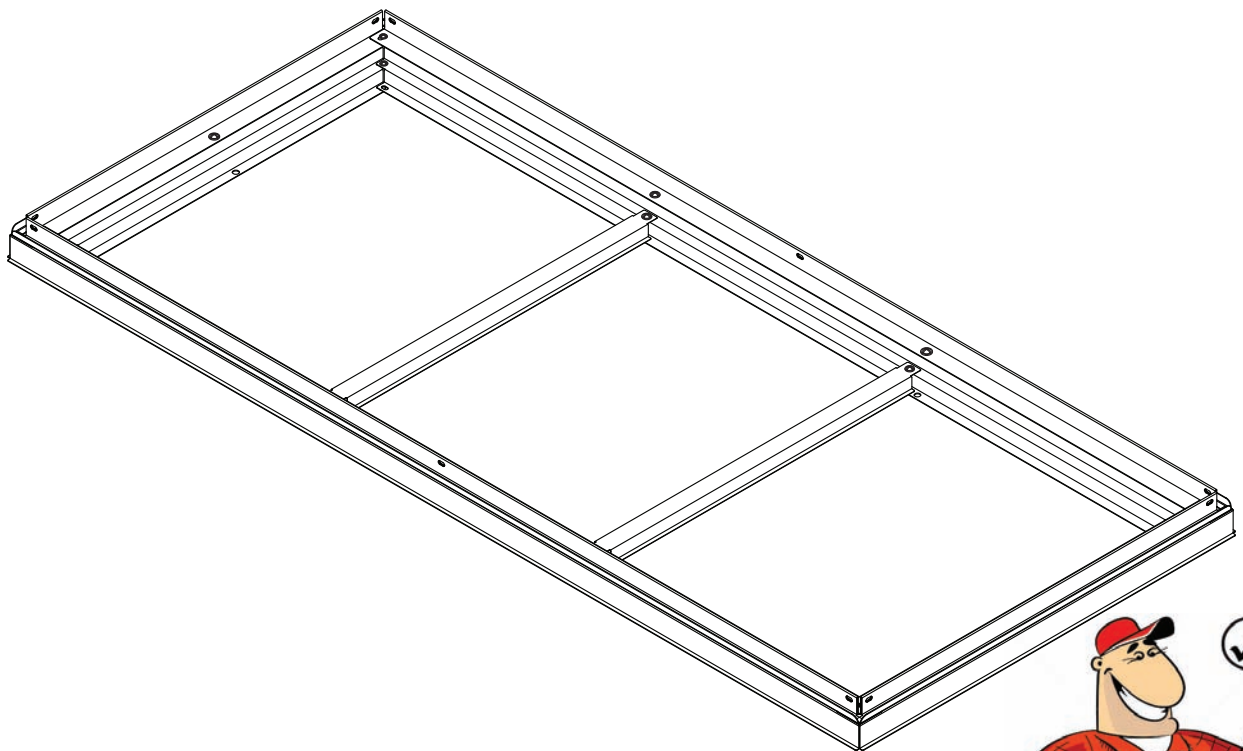
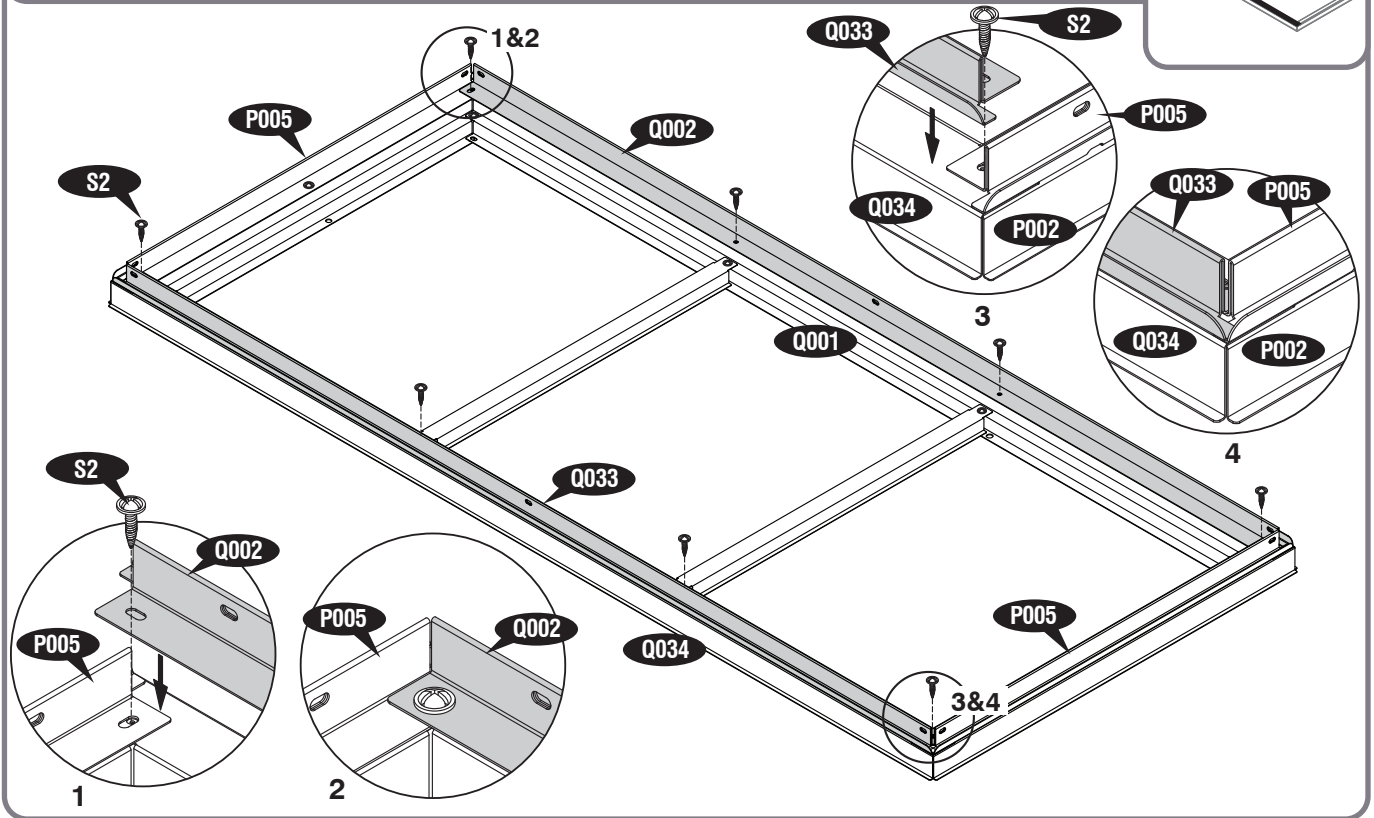
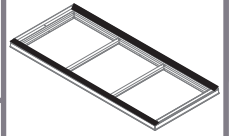



- 3**
- |                       |                      |                        |
|-----------------------|----------------------|------------------------|
| EN Walls & Columns    | CS Zdi a kolumny     | IT Pareti & Colonne    |
| FR Murs et colonnes   | SK Steny a stĺpy     | PL Ściany i Kolumny    |
| DE Wände und Säulen   | SL Stene in stebri   | RO Pereți și stâlpi    |
| ES Columnas y paredes | HR Zidovi i Kolumne  | BG Стени & Колони      |
| PT Paredes e Colunas  | HU Falak és oszlopok | TR Duvarlar & Sütunlar |
| NL Panelen en stijlen | SV Väggar & Kolumner |                        |

- |                       |                                   |                                   |
|-----------------------|-----------------------------------|-----------------------------------|
| EN Parts needed       | CS Potřebné součásti              | IT Parti occorrenti               |
| FR Pièces nécessaires | SK Potřebné části                 | PL Niezbędne elementy             |
| DE Benötigte Teile    | SL Dele, ki jih boste potrebovali | RO Elementele componente necesare |
| ES Piezas necesitadas | HR Dijelovi potreban              | BG Необходими части               |
| PT Peças Necessárias  | HU Szükséges részek               | TR Gerekli parçalar               |
| NL Onderdelen nodig   | SV Delar som behövs               |                                   |



Q003	1
Q004	1
P008	2
Q005	1
Q006	1
Q007	1
Q008	1
Q009	1
P014	2
P015	2
Q010	1

P017	1
P018	1
Q011	1
P025	2
Q029	1
Q031	1
A037	2
P026	2
A054	36
A055	13

- EN Do not fully tighten the bolts & nuts until complete the assembly.  
 FR Ne pas serrer les boulons & écrous jusqu'à compléter l'assemblage.  
 DE Nicht die Schrauben festziehen & Nüsse bis vervollständigen Si edie Versammlung.  
 ES No apriete completamente los pernos & tuercas hasta completan el montaje.  
 PT Não aperte os parafusos totalmente & nozes até completar a montagem  
 NL Doen niet volledig draai de bouten & noten tot complete de same nstelling.  
 CS Neotvírejte šrouby a matice, dokud nedojde k dokončení sestavy.  
 SK Skrutky a matice úplne neutiahnite, kým nedokončíte zostavu.  
 SL Ne pritegnite vijakov in matice do konca, dokler ne dokončate montaže.  
 HR Nemojte potpuno zategnuti vijke i matice dok ne dovršite sklop.  
 HU Ne húzza meg teljes mértékben a csavarokat és anyákat, amíg a szerelést befejezi.  
 SV Inte helt dra åt bultarna & nötter till komplett montering.  
 IT Non serrare completamente i bulloni & dadi fino a completano l'assemblaggio.  
 PL Nie pełni dokręć śruby mocujące & orzechy do zakończenia montażu.  
 RO Nu strângeți complet șuruburile și piulițele până când nu se termină ansamblul.  
 BG Не затягайте напълно болтовете и гайките, докато не завършите монтажа.  
 TR Montajı tamamlayana kadar civataları ve somunları tam olarak sıkmayın.



1

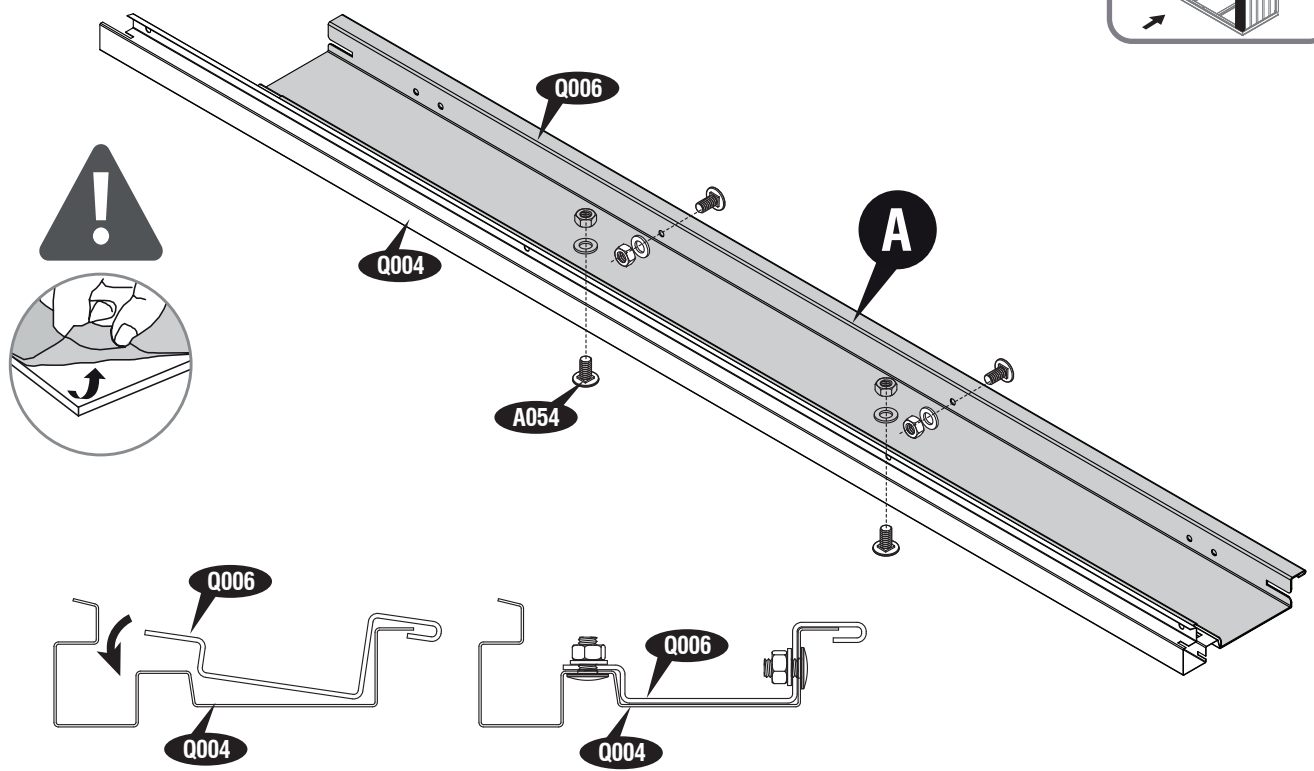
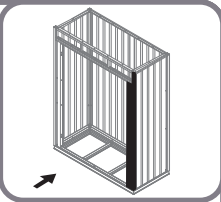
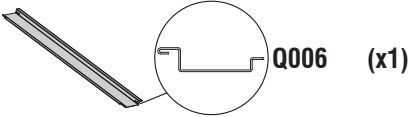
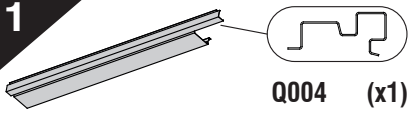

2

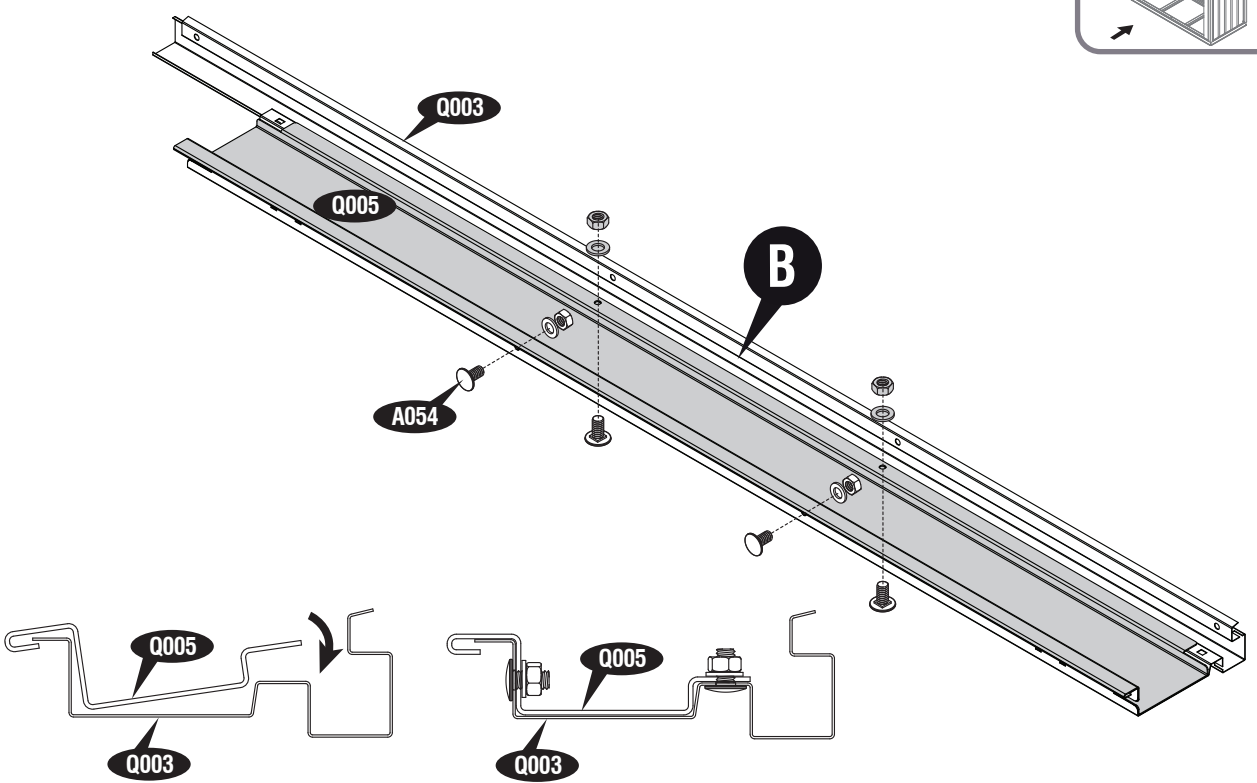
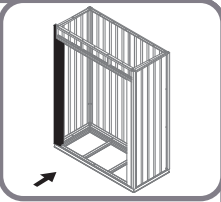
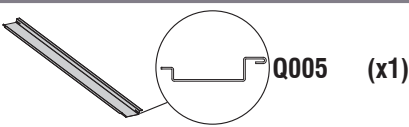
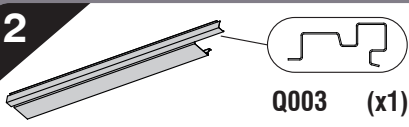

3

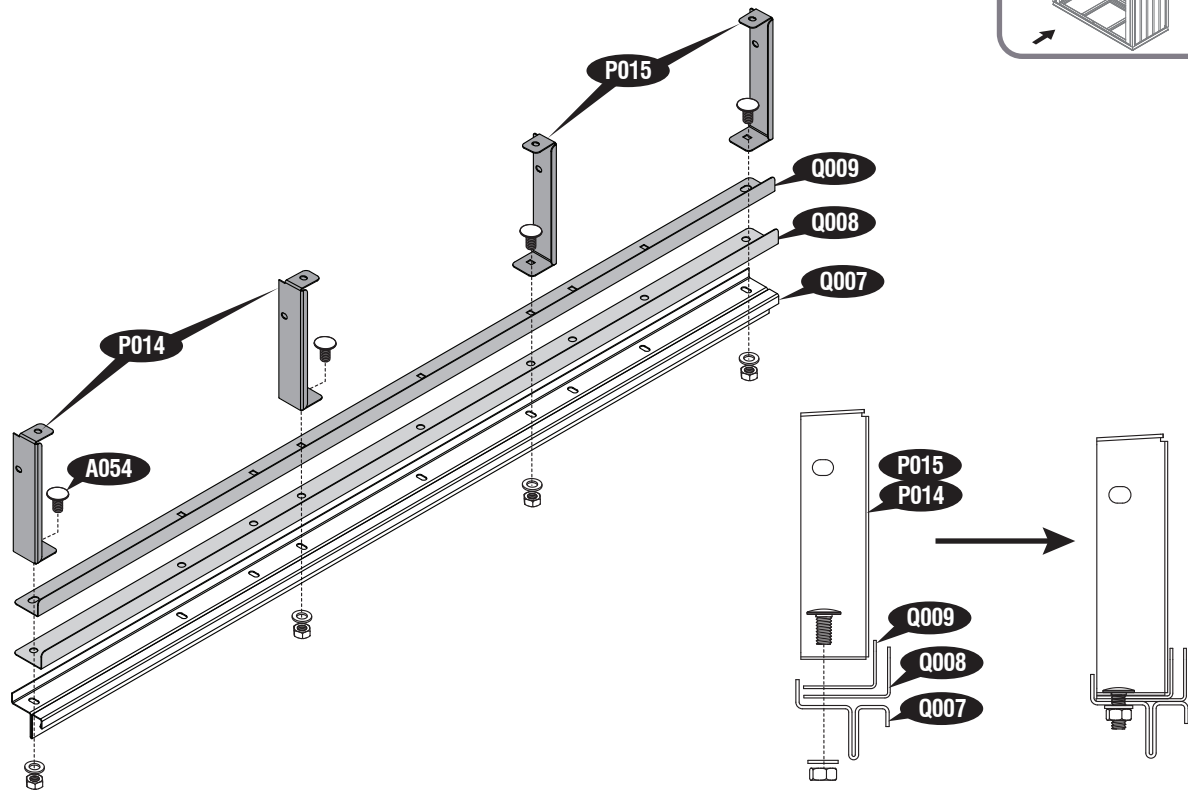
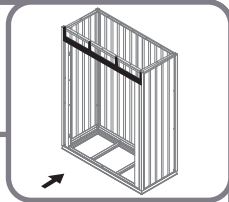
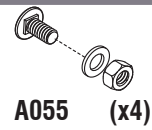
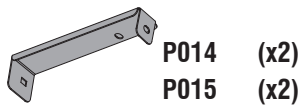
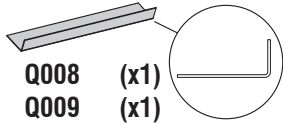
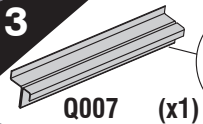

4

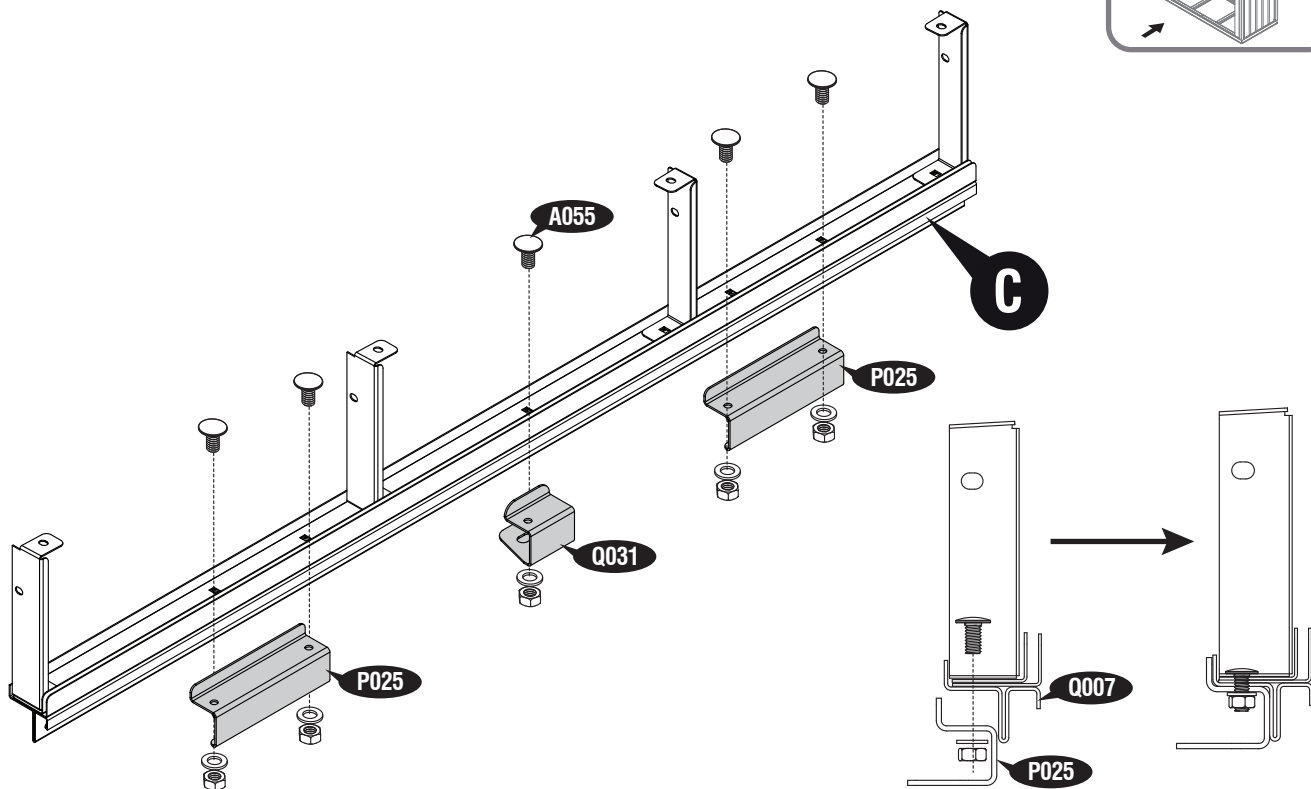
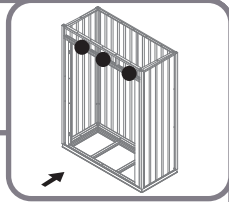
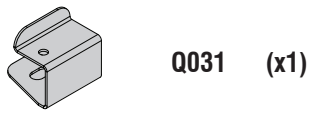
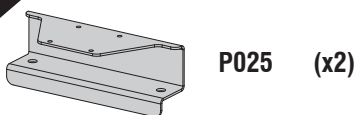

5

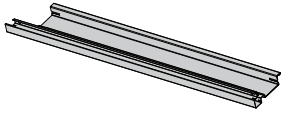

**A** (x1)

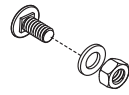

A054 (x1)

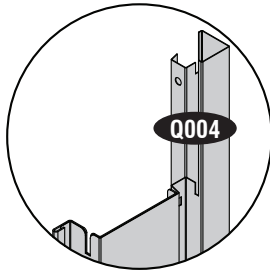

1

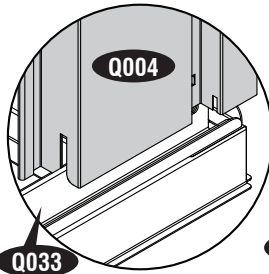

2

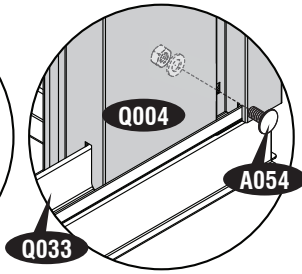

3

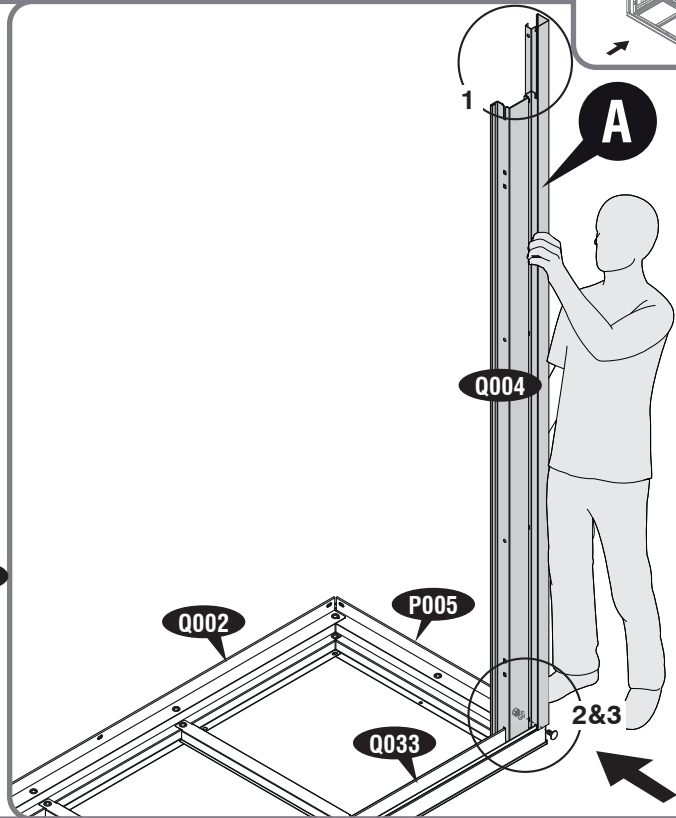

6



P026 (x1)



A054 (x3)

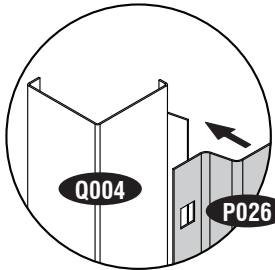
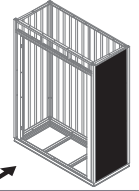

1

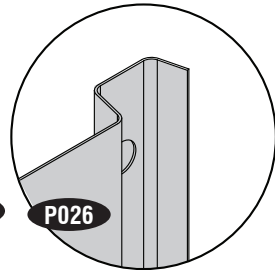

2

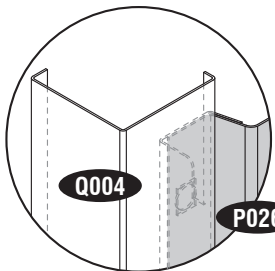

3

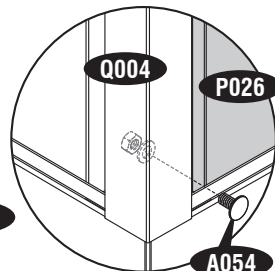

4

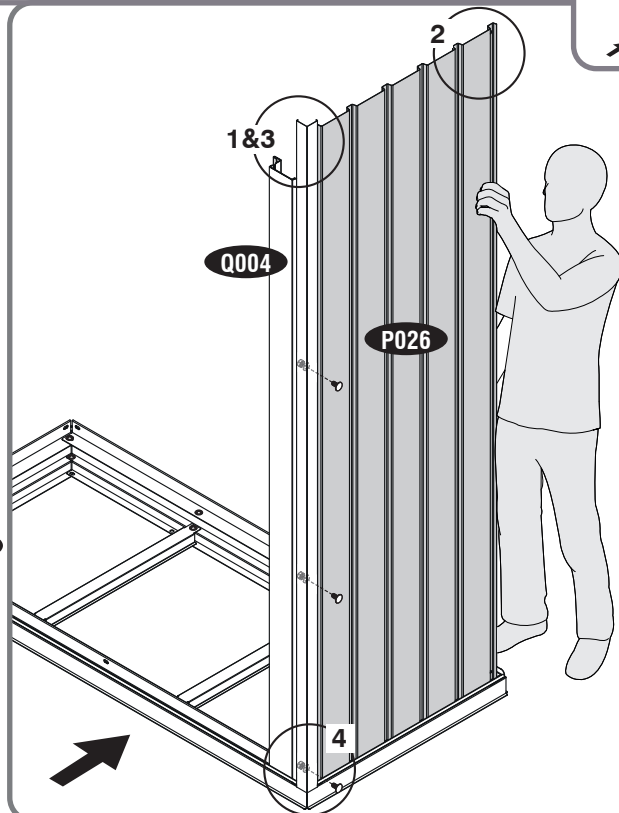

7

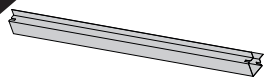

P008 (x1)

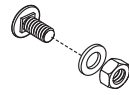

A054 (x3)

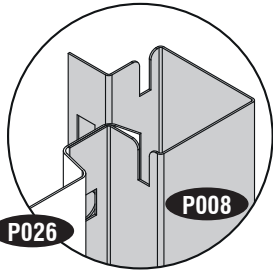
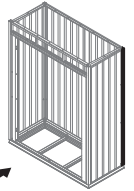

1

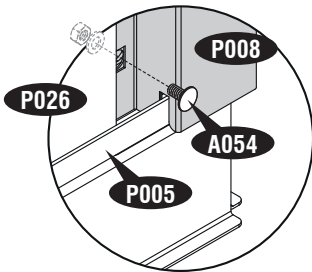

2

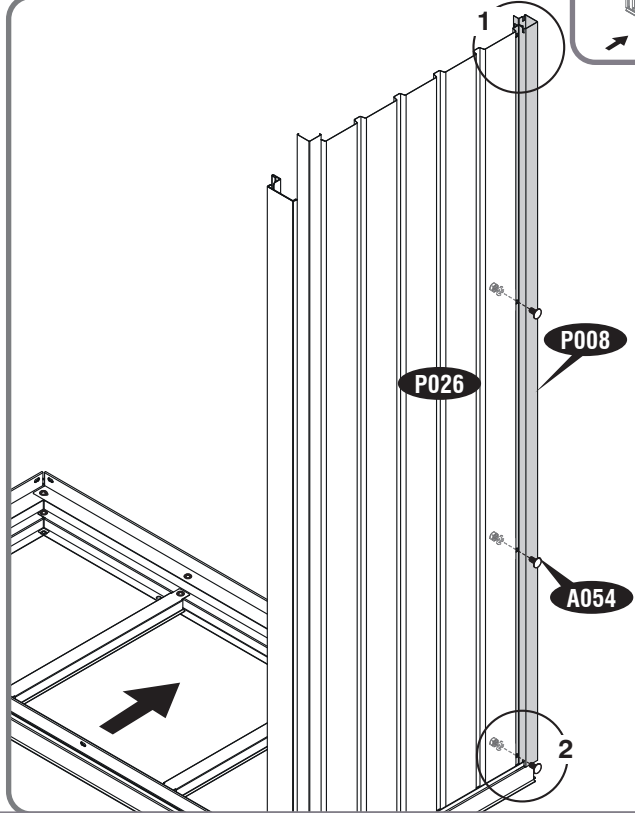

8

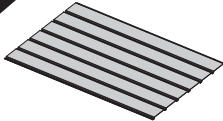

A037 (x1)

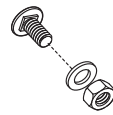

A054 (x3)

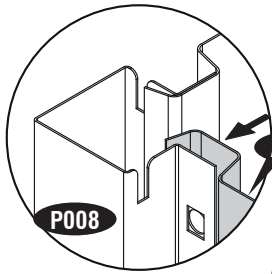

1



2

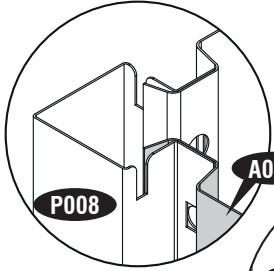

3

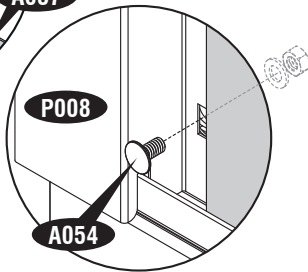

4

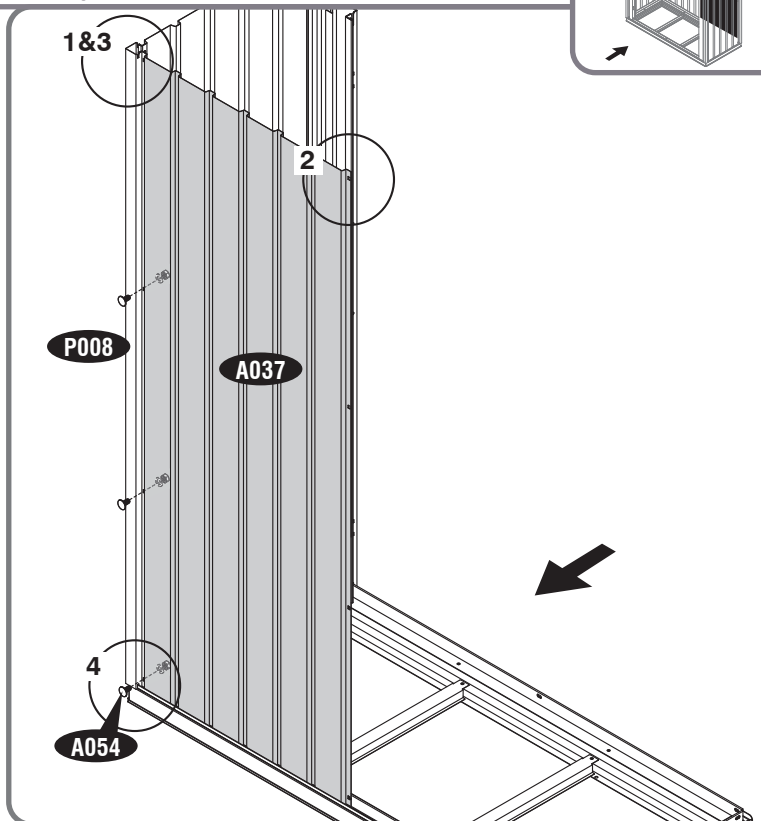

9

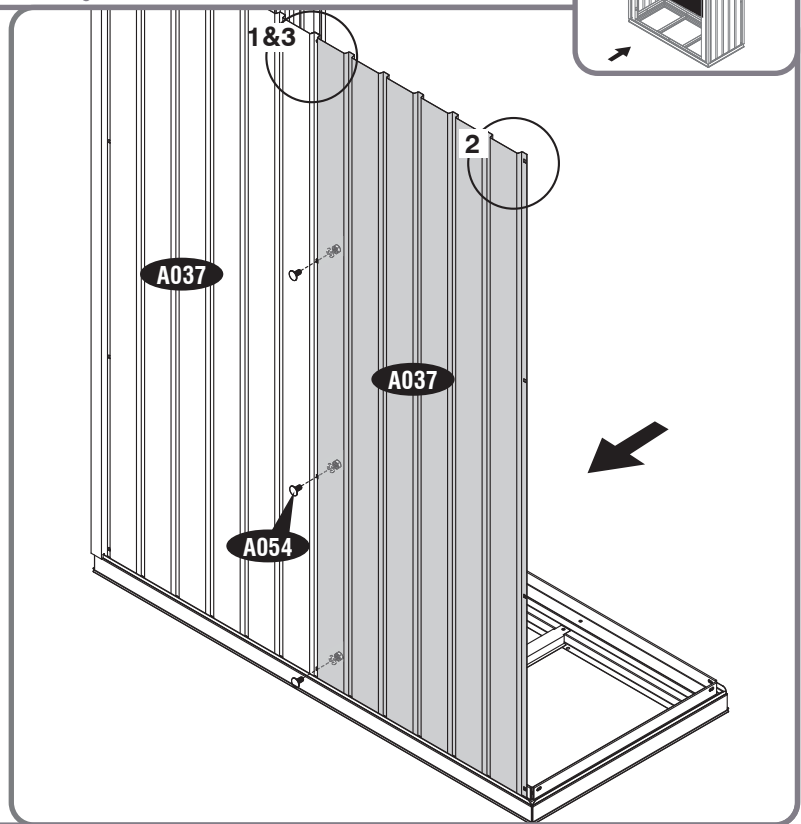
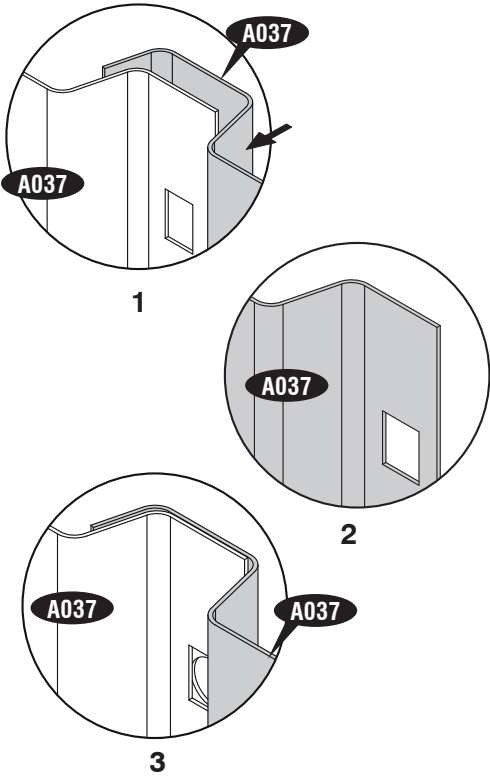
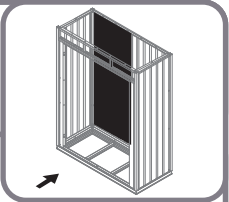
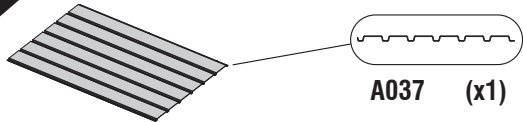

10

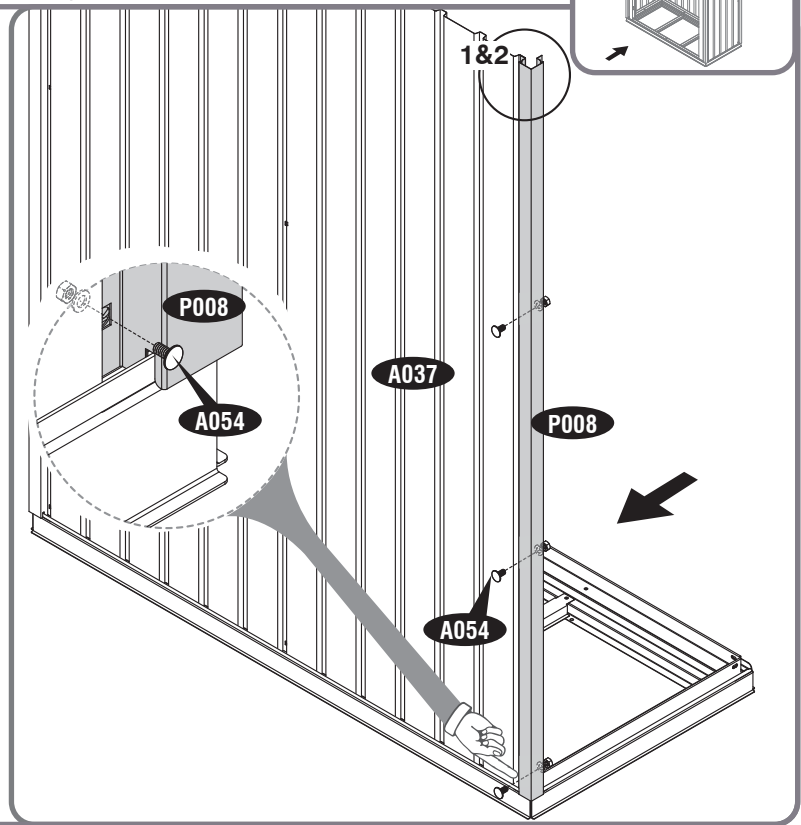
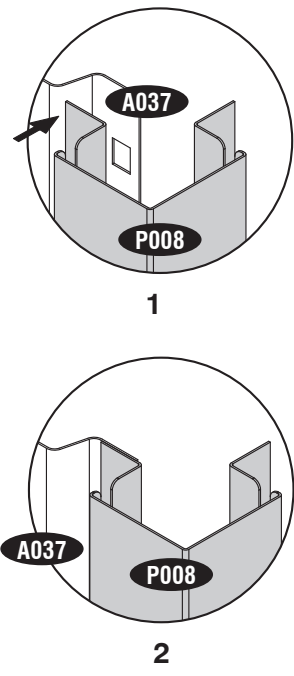
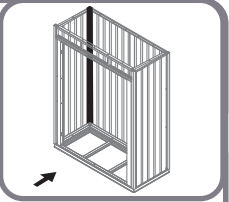
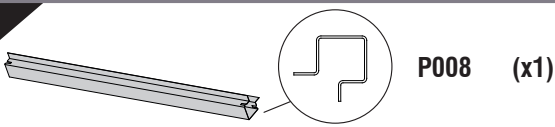

11

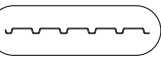

P026 (x1)

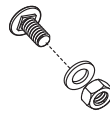

A054 (x3)

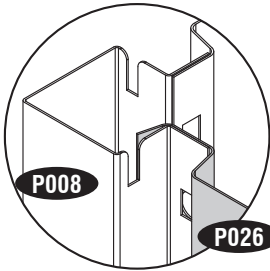
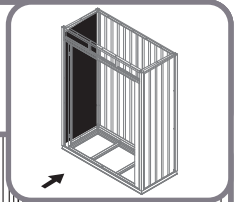

P008

P026

1

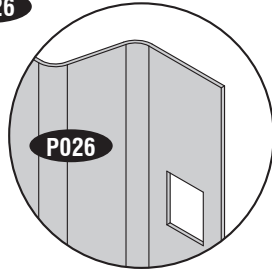

P026

2

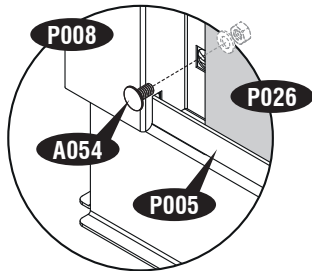

P008

A054

P026

3

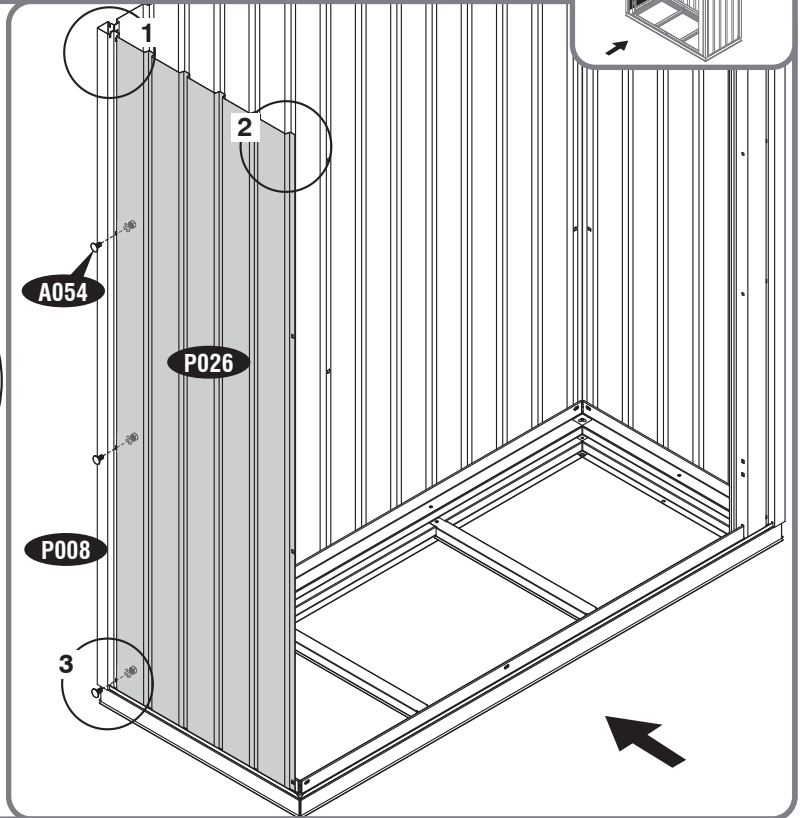

A054

P026

P008

3



12

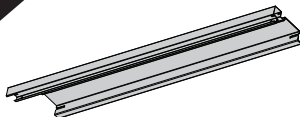

B (x1)

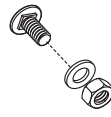

A054 (x4)

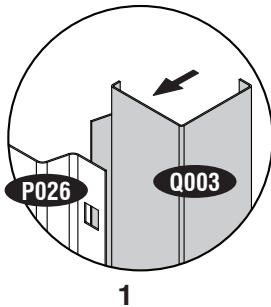
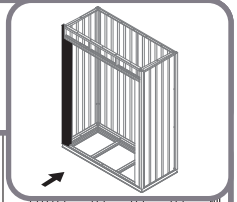

P026

Q003

1

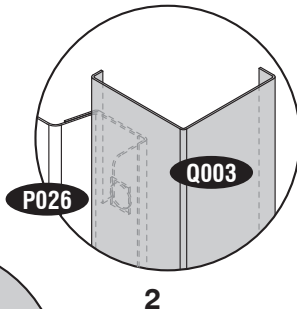

P026

Q003

2

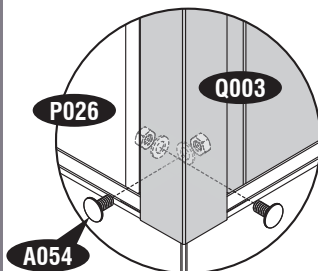

P026

Q003

A054

3

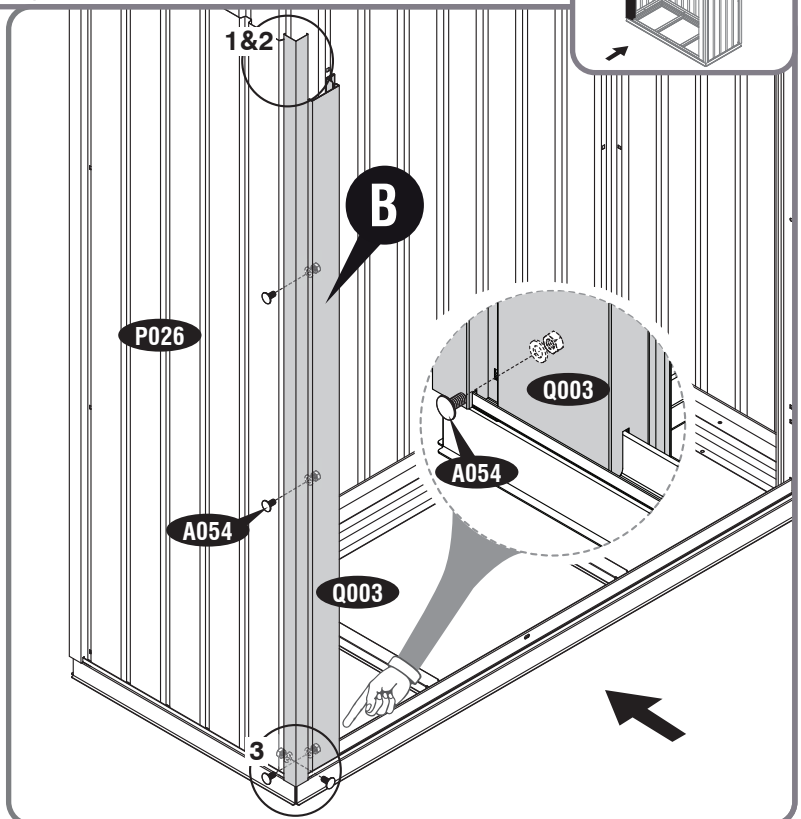

1&2

P026

B

A054

Q003

3

21

13

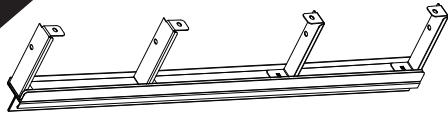

**C** (x1)



A054 (x2)

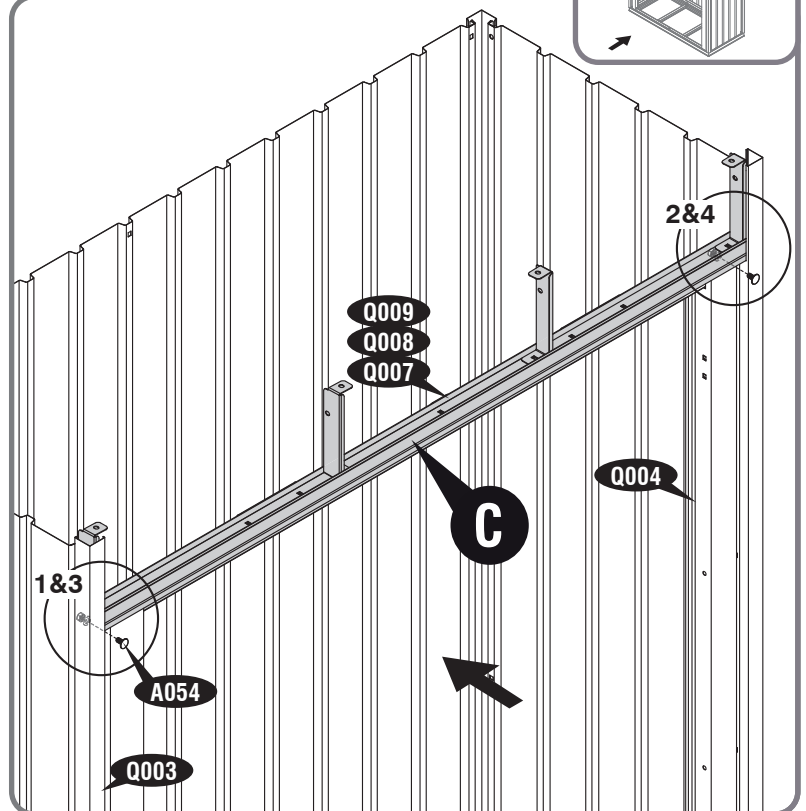
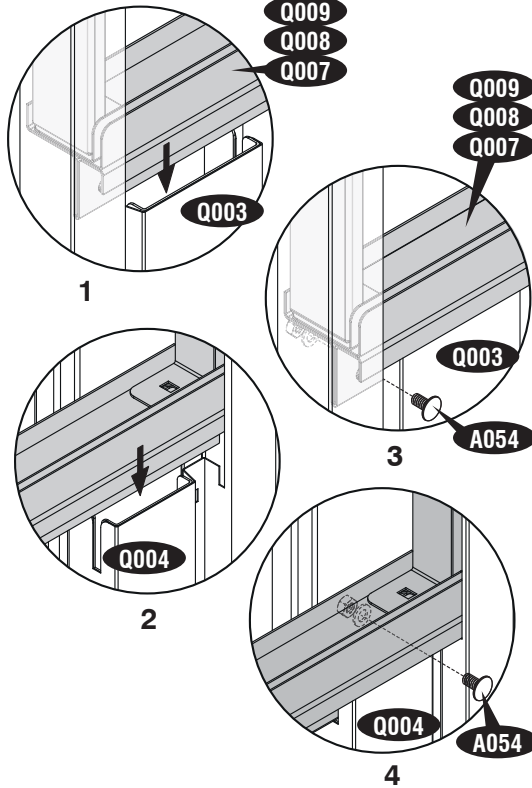
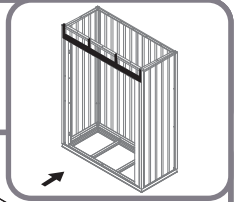

14

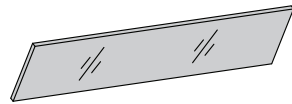

Q029 (x1)

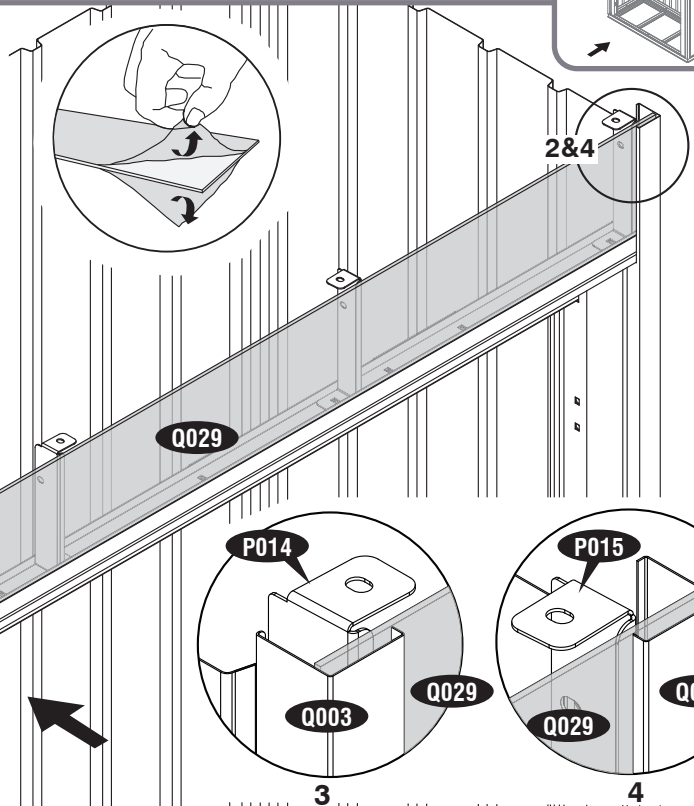
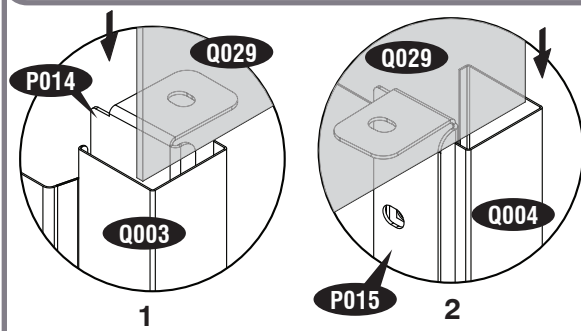
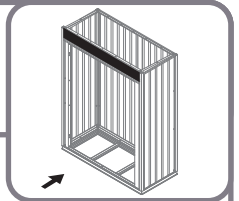

15

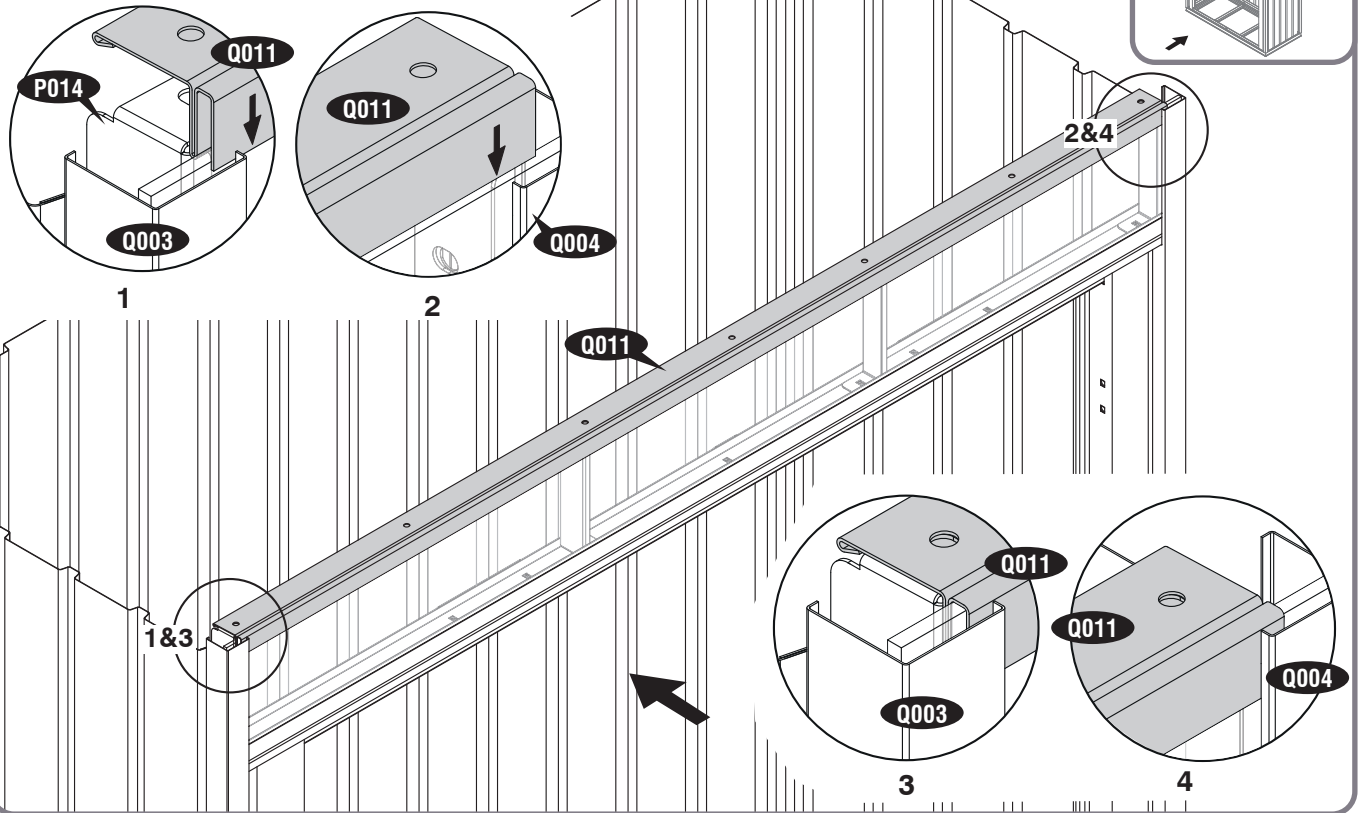
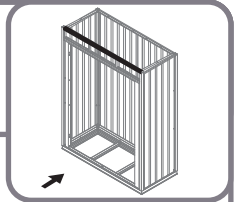
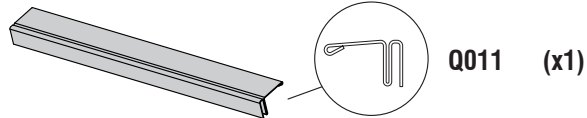

16

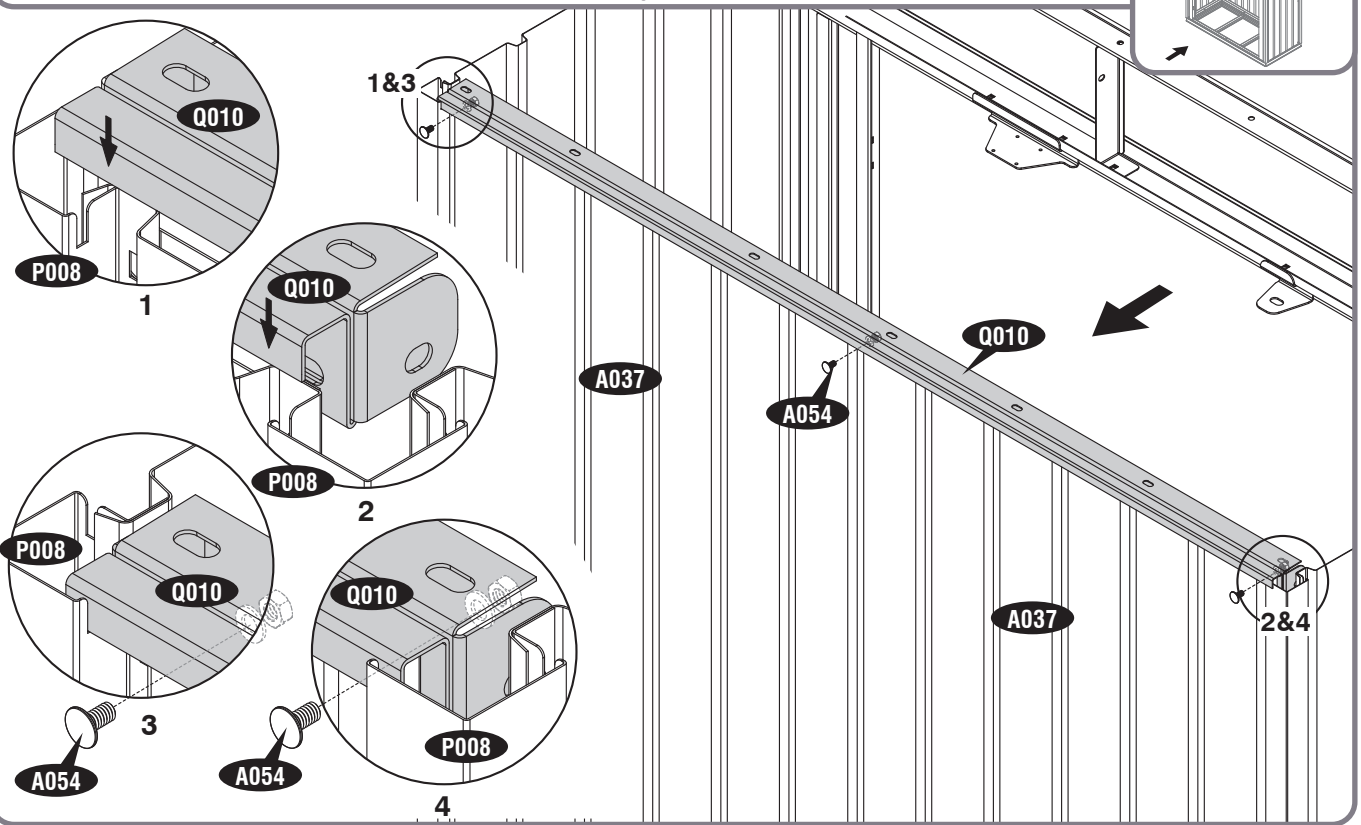
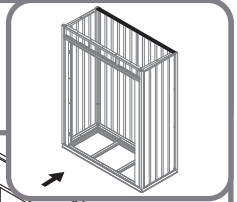

23



17

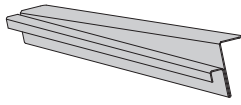

P018 (x1)

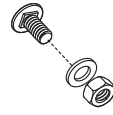

A055 (x2)

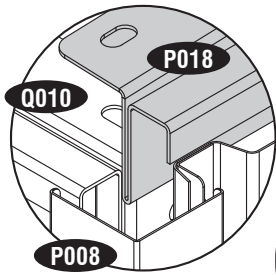
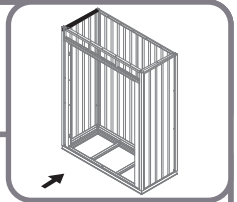

1

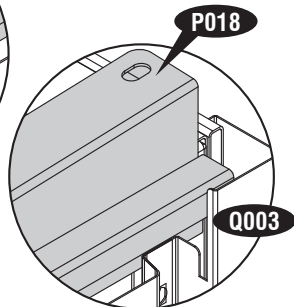

2

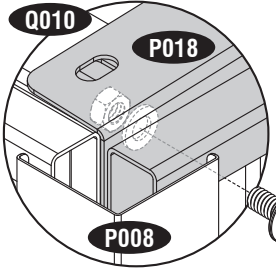

3

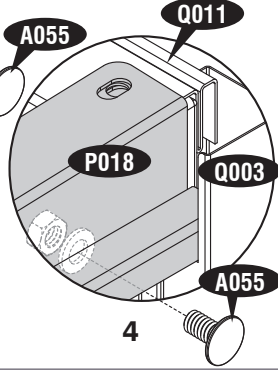

4

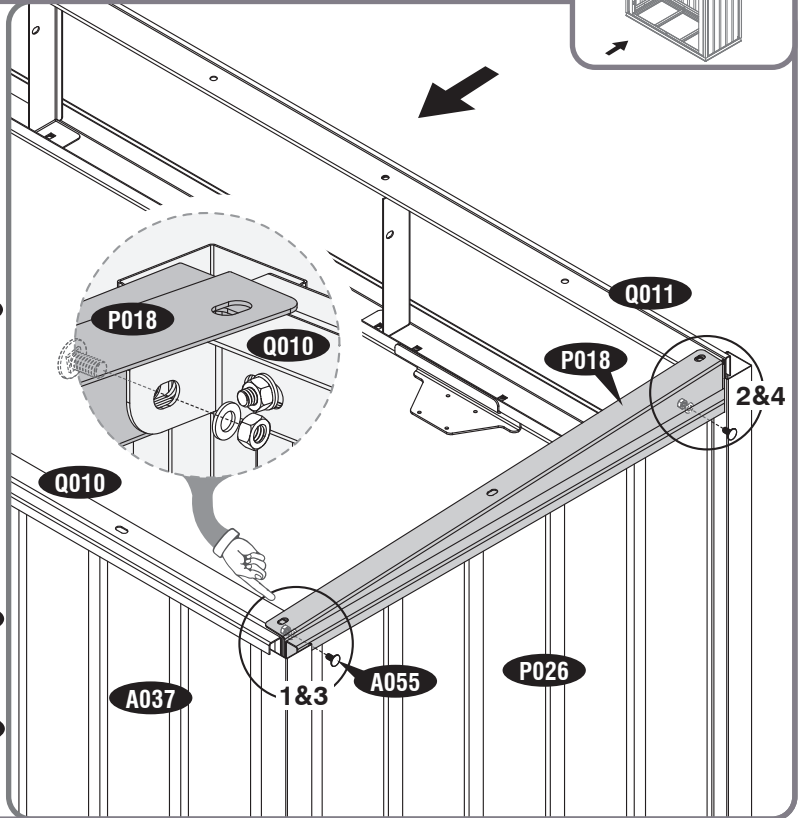

18

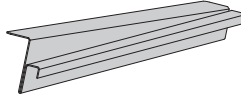

P017 (x1)

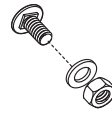

A055 (x2)

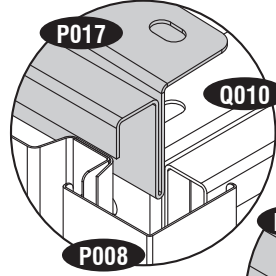
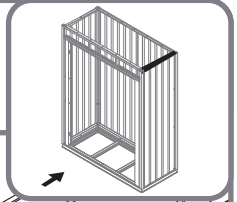

1

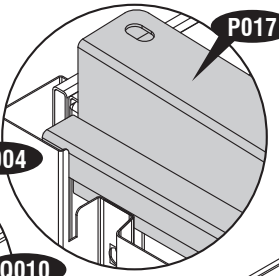

2

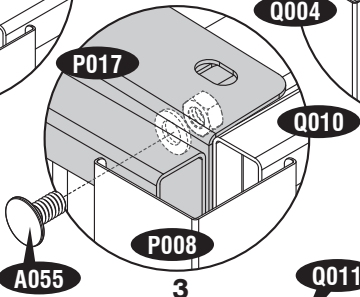

3

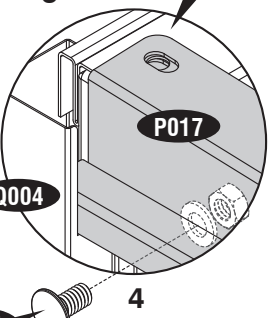

4

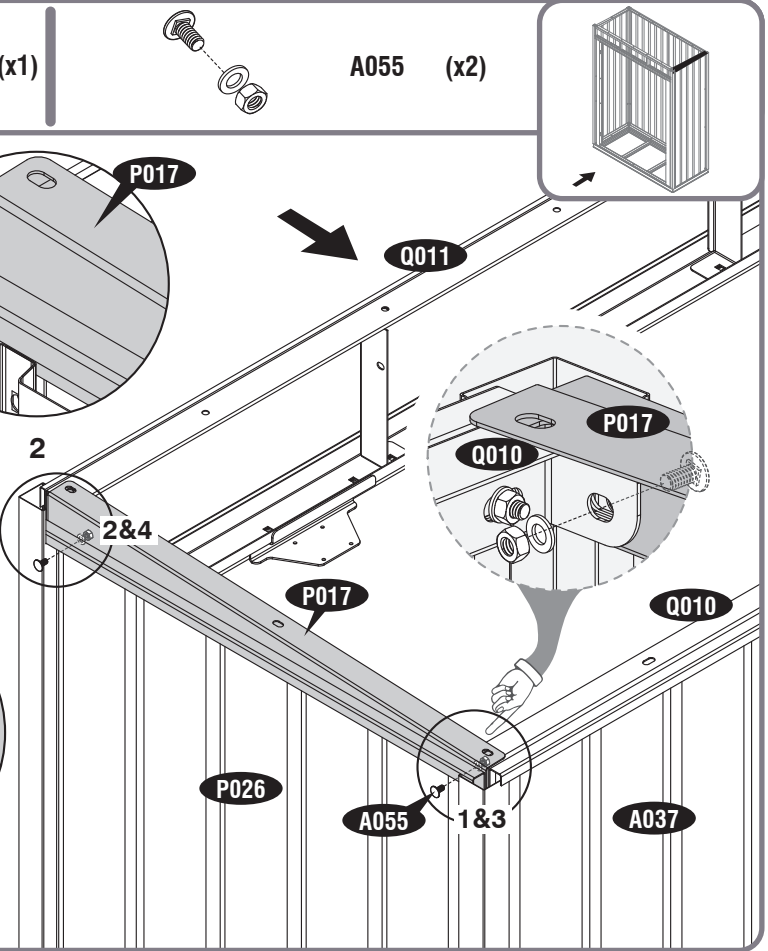



4

- |             |            |               |
|-------------|------------|---------------|
| EN Roof     | CS Střecha | IT Soffitto   |
| FR Toit     | SK Strecha | PL Dach       |
| DE Dach     | SL Streha  | RO Acoperișul |
| ES El techo | HR Krov    | BG Покрив     |
| PT Telhado  | HU Tető    | TR Çatı       |
| NL Dak      | SV Tak     |               |

- |                       |                                   |                                   |
|-----------------------|-----------------------------------|-----------------------------------|
| EN Parts needed       | CS Potřebné součásti              | IT Parti occorrenti               |
| FR Pièces nécessaires | SK Potřebné části                 | PL Niezbędne elementy             |
| DE Benötigte Teile    | SL Dele, ki jih boste potrebovali | RO Elementele componente necesare |
| ES Piezas necesitadas | HR Dijelovi potreban              | BG Необходими части               |
| PT Peças Necessárias  | HU Szükséges részek               | TR Gerekli parçalar               |
| NL Onderdelen nodig   | SV Delar som behövs               |                                   |

Q050	1
P051	1
P052	1
Q051	1
Q052	2
A054	11
A055	6
S2	6



**1**

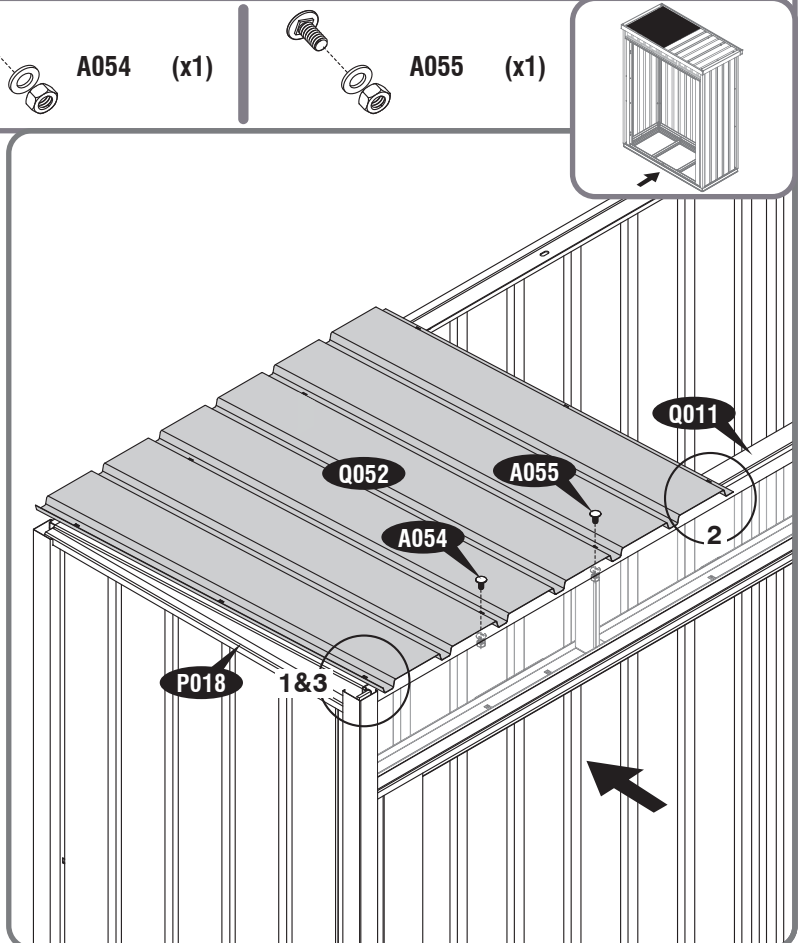
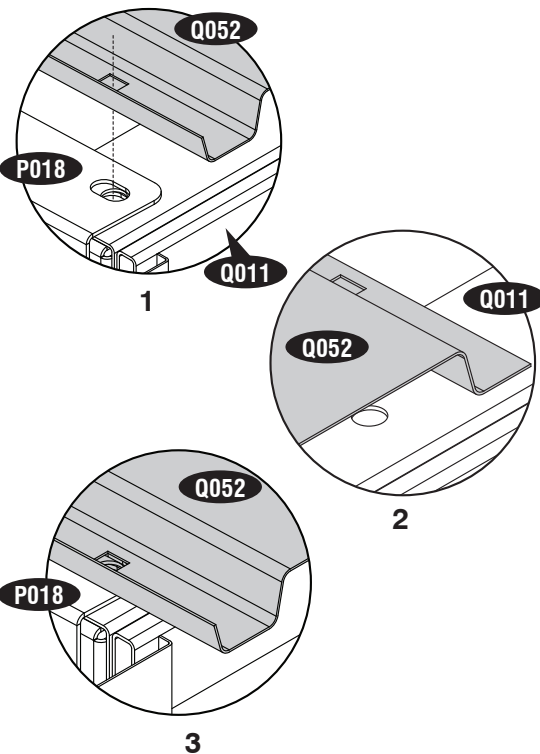

2

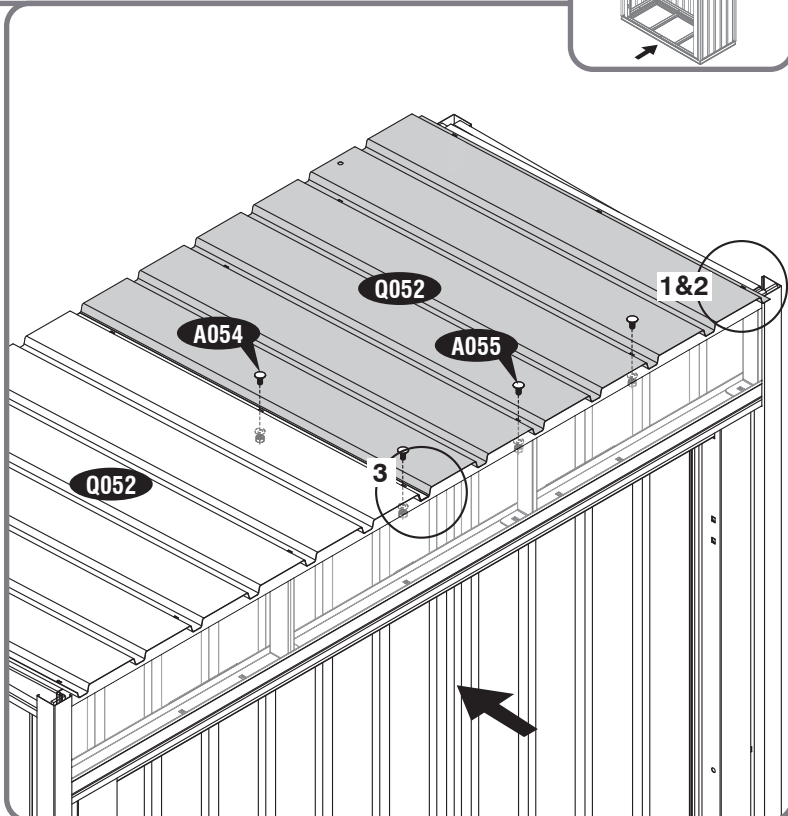
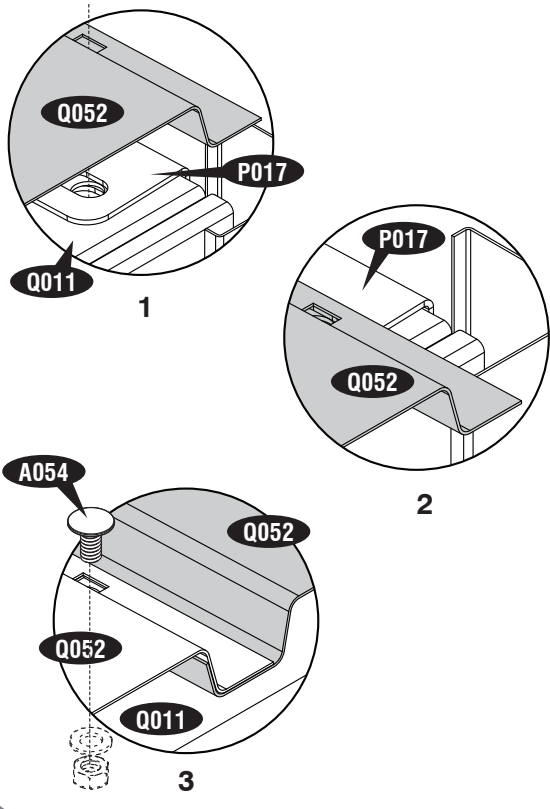
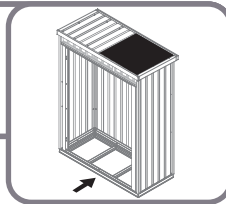
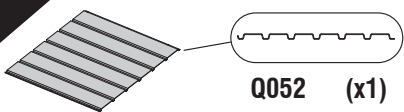

3

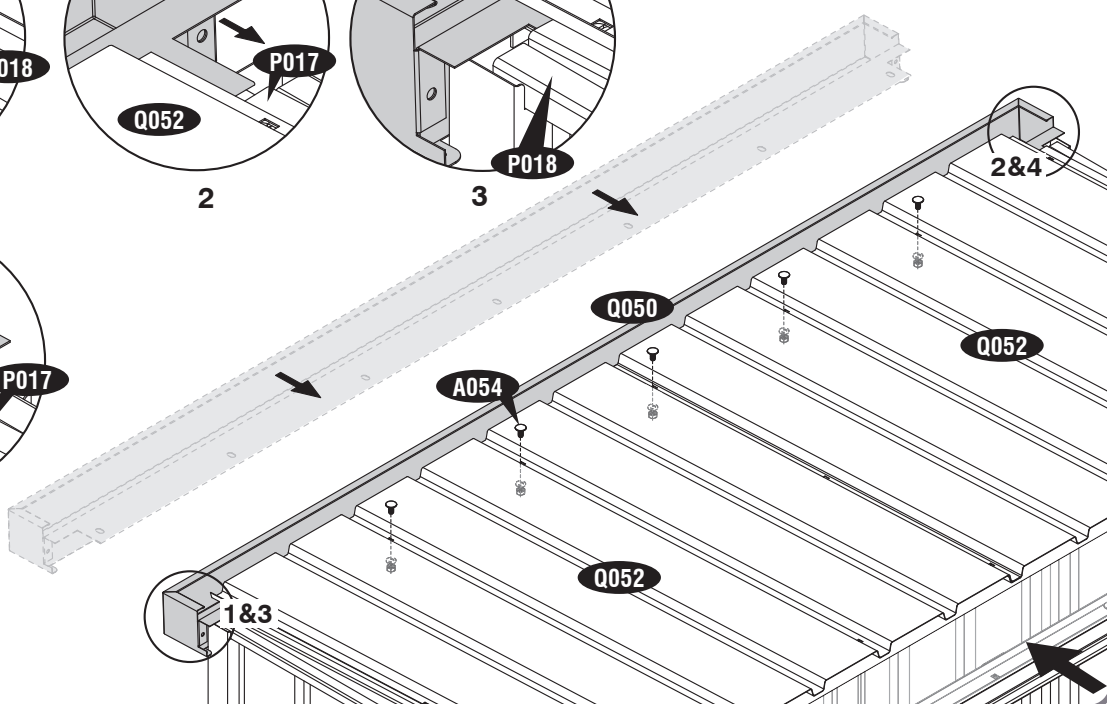
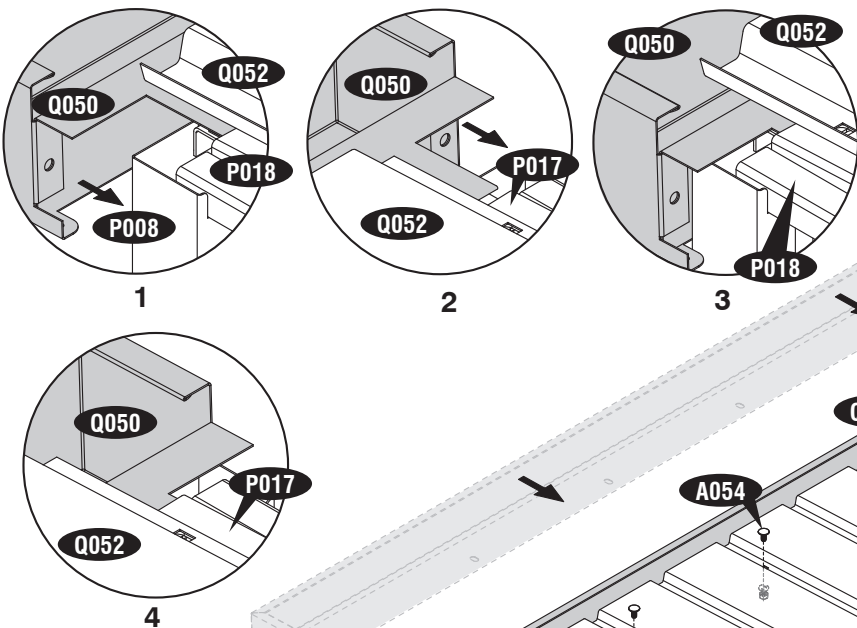
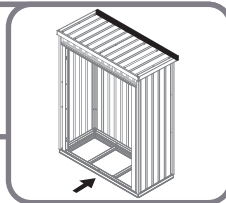
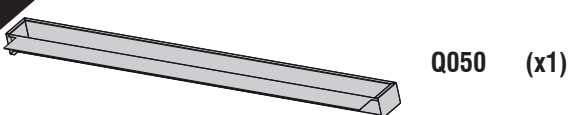

4

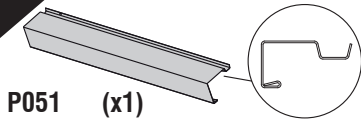

P051 (x1)

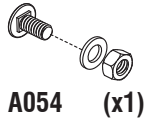

A054 (x1)

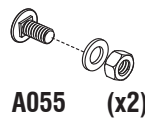

A055 (x2)

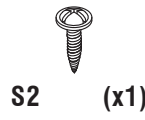

S2 (x1)

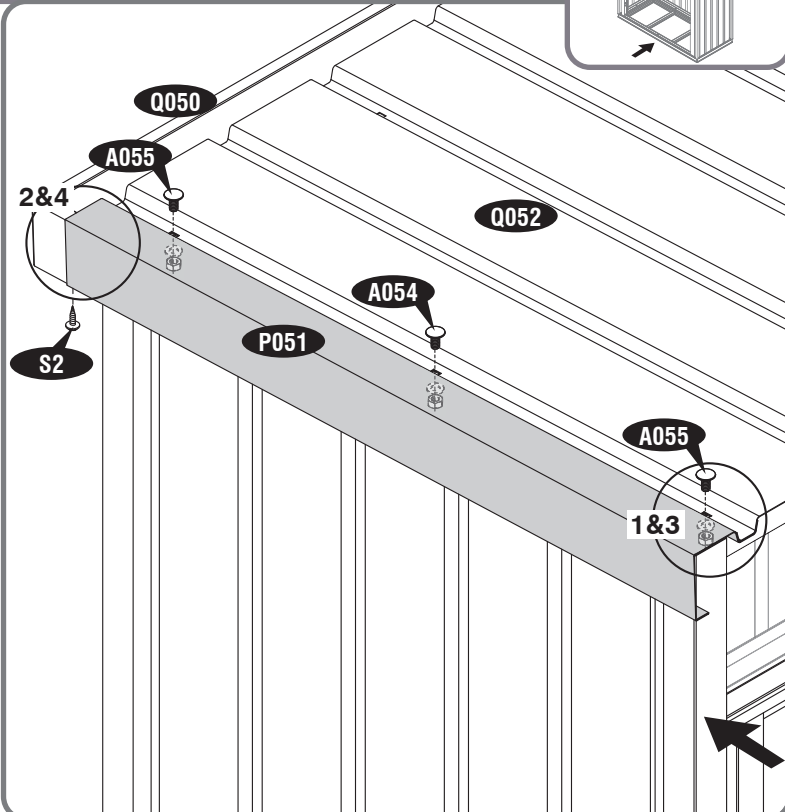
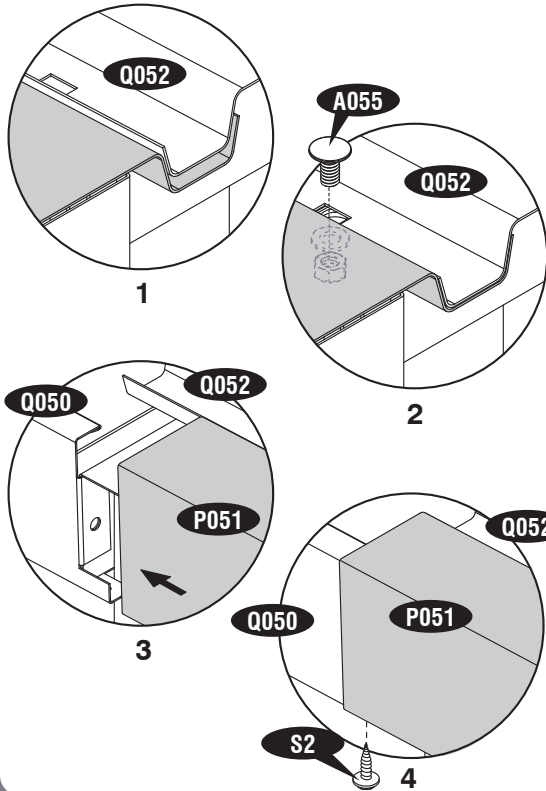
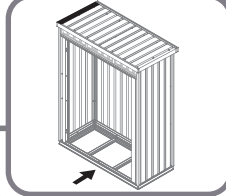

5

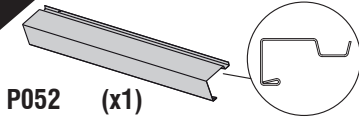

P052 (x1)

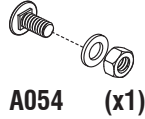

A054 (x1)

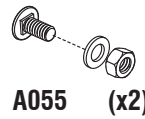

A055 (x2)



S2 (x1)

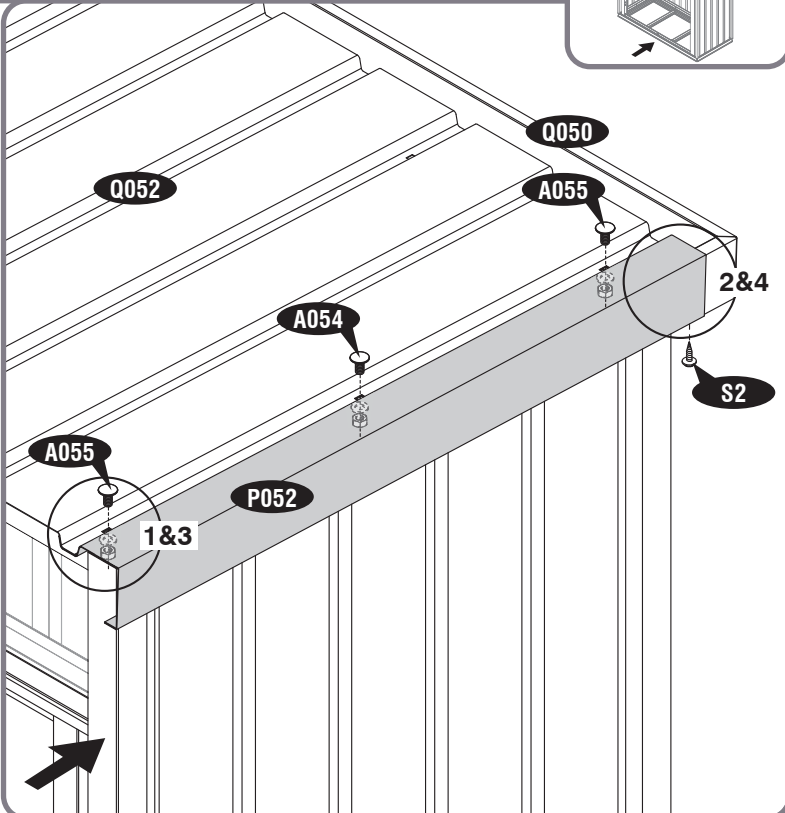
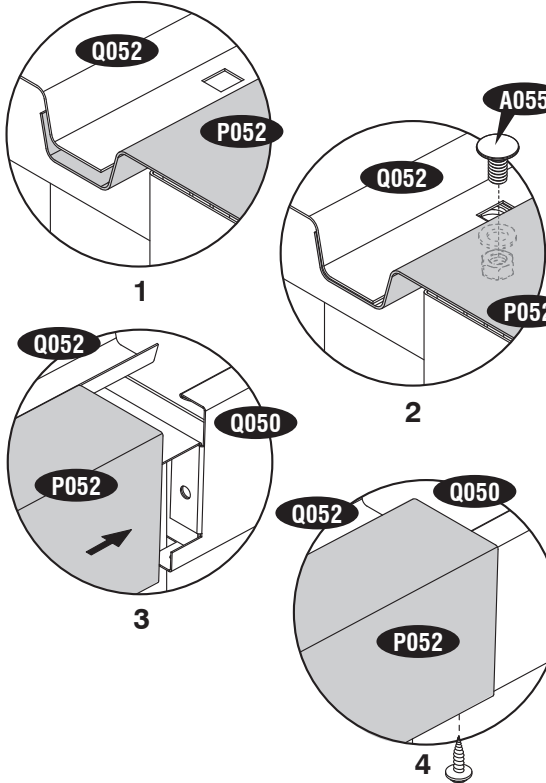
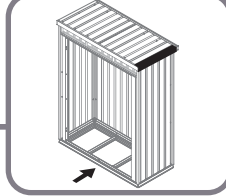

6

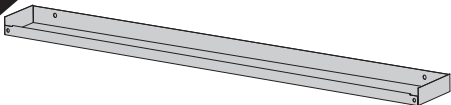

Q051 (x1)



S2 (x4)

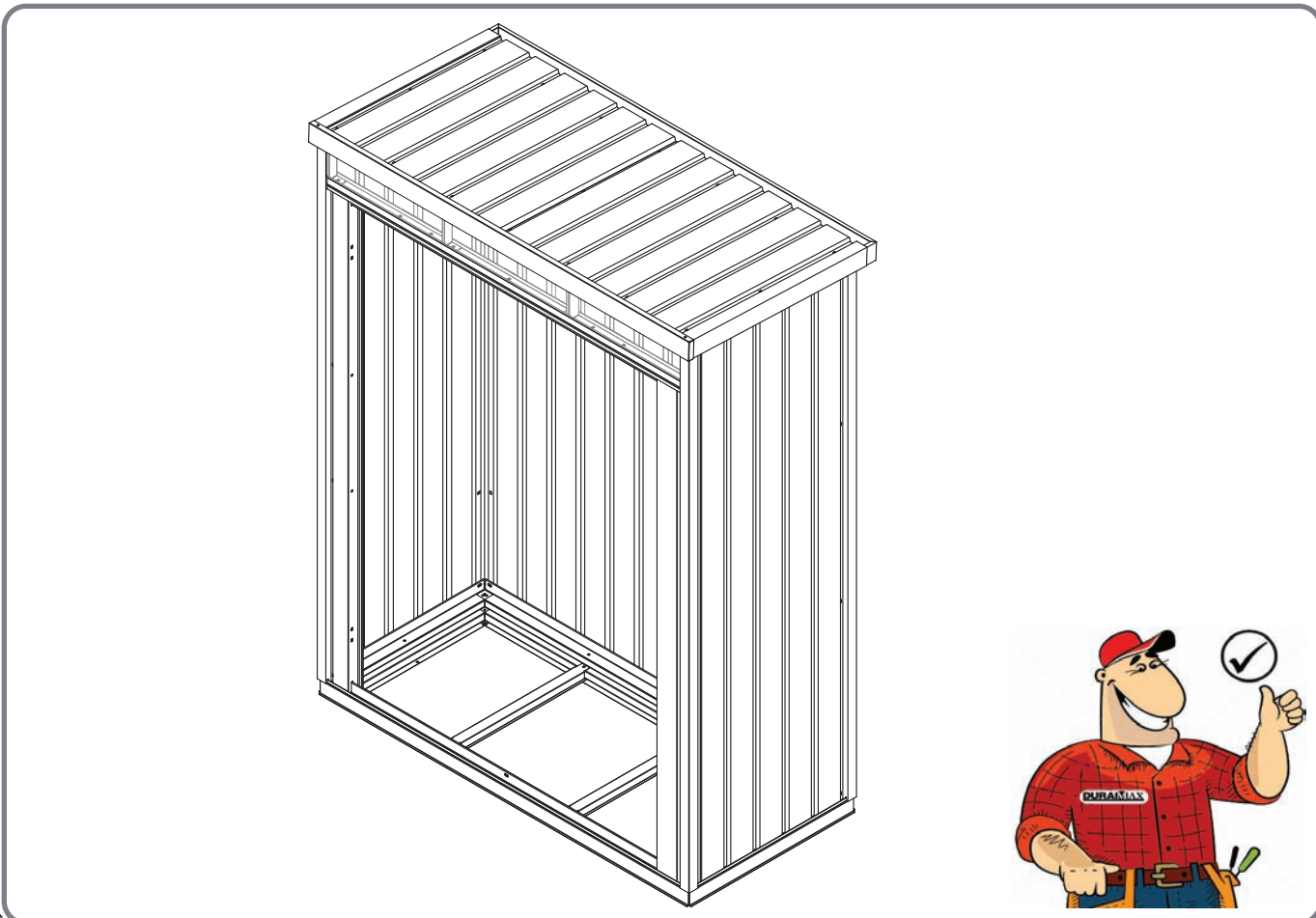
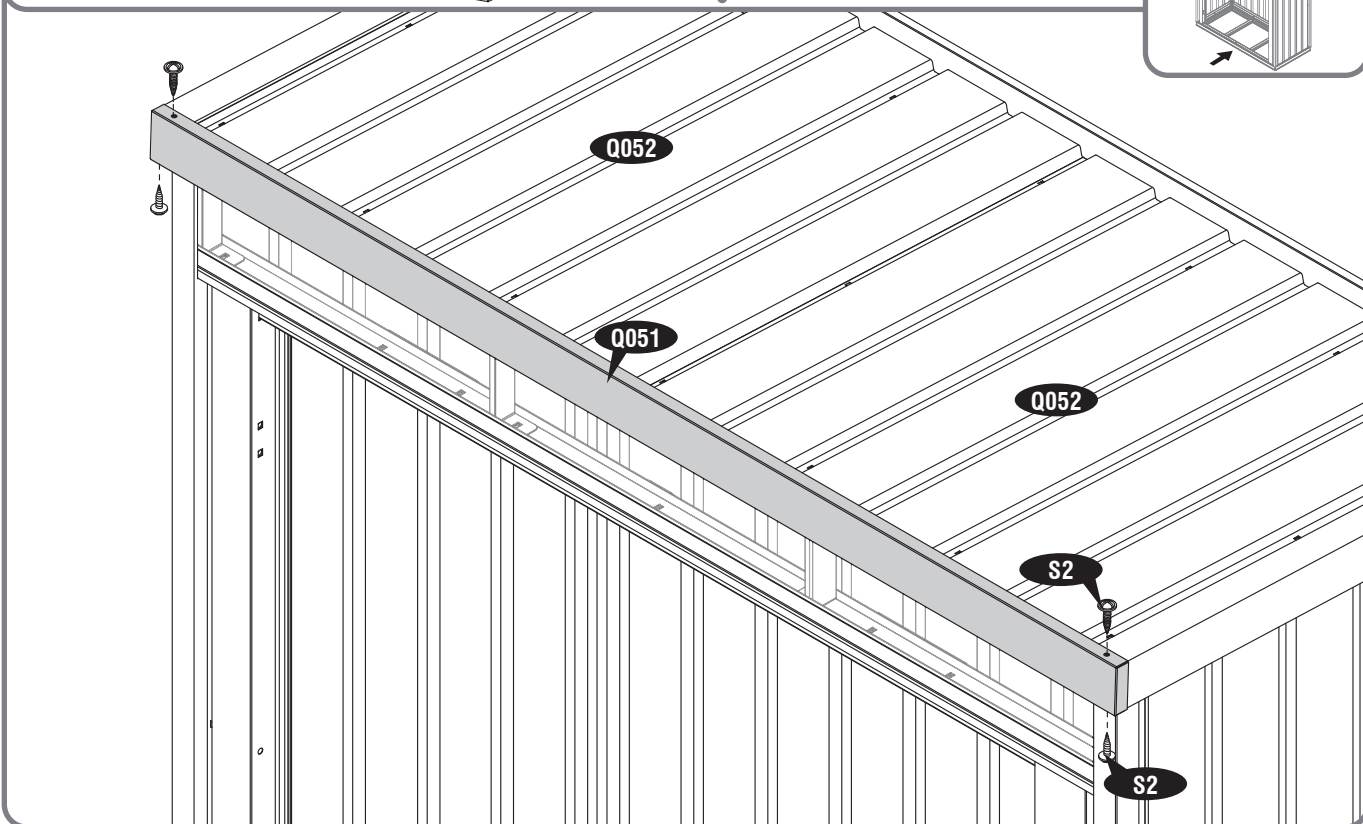
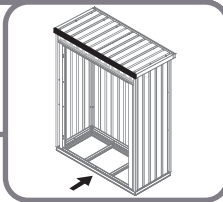



# 5

- |              |          |          |
|--------------|----------|----------|
| EN Door      | CS Dveře | IT Porta |
| FR Porte     | SK Dvere | PL Drzwi |
| DE Die Tür   | SL Vrata | RO Ușa   |
| ES La puerta | HR Vrata | BG Врата |
| PT Porta     | HU Ajtó  | TR Kapı  |
| NL De deur   | SV Dörr  |          |

- |                       |                                   |                                   |
|-----------------------|-----------------------------------|-----------------------------------|
| EN Parts needed       | CS Potřebné součásti              | IT Parti occorrenti               |
| FR Pièces nécessaires | SK Potřebné části                 | PL Niezbędne elementy             |
| DE Benötigte Teile    | SL Dele, ki jih boste potrebovali | RO Elementele componente necesare |
| ES Piezas necesitadas | HR Dijelovi potreban              | BG Необходими части               |
| PT Peças Necessárias  | HU Szükséges részek               | TR Gerekli parçalar               |
| NL Onderdelen nodig   | SV Delar som behövs               |                                   |

A030	2
Q016	1
Q017	1
Q028	1
DLT	1

C22M	2
A044	2
A045	2
Q032	1
A053	1 Slabs

A054	8
TB	2
S2	26



- 1
- DLT (x1)
  - (x1)
  - (x1)
  - (x1)
  - (x2)
  - (x2)
  - Q028 (x1)
  - A030 (x1)
  - S2 (x3)
  - Q016 (x1)

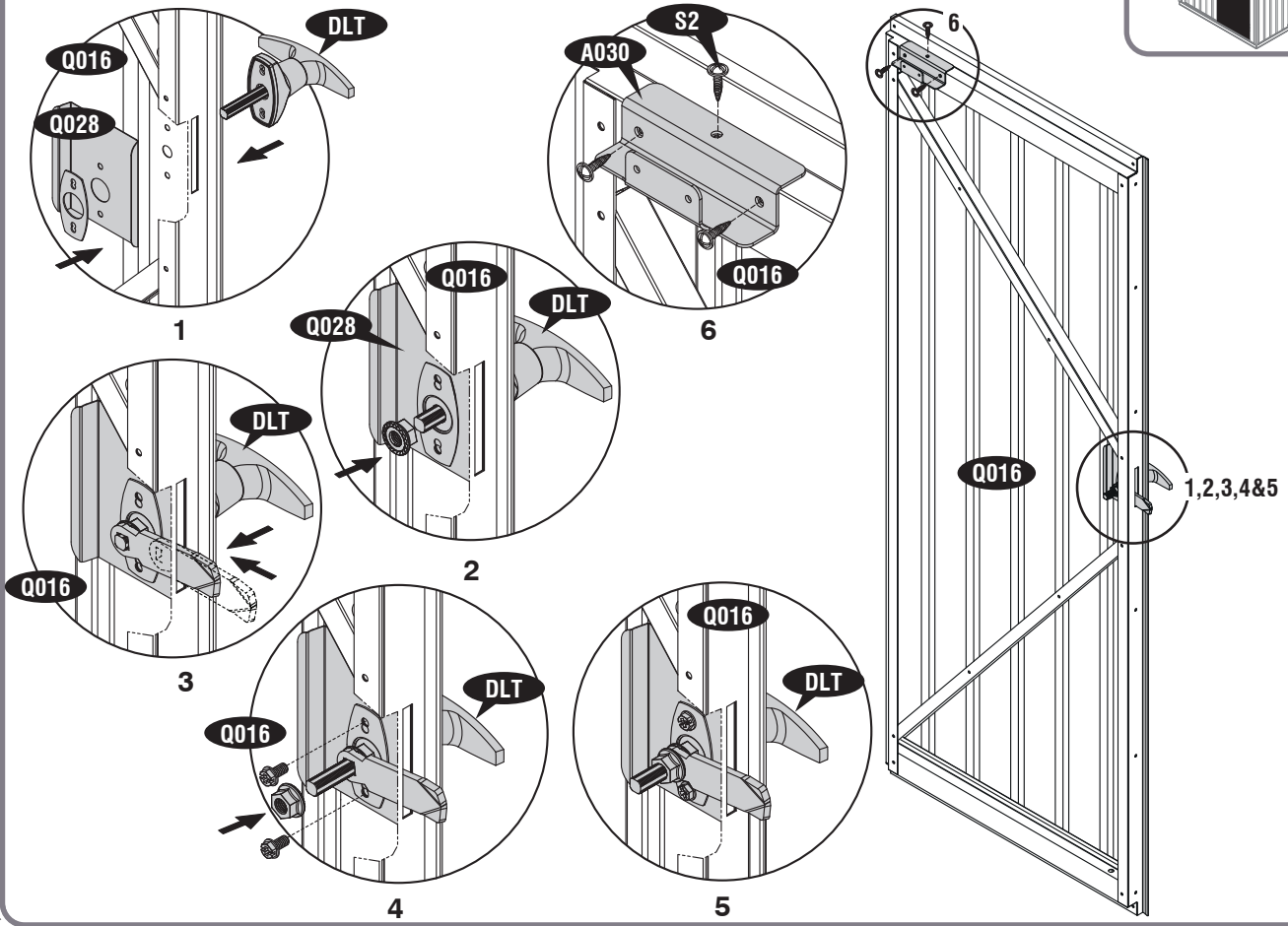
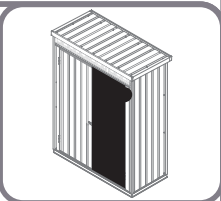

2

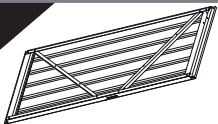

Q017 (x1)

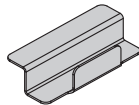

A030 (x1)

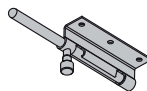

TB (x2)



S2 (x9)

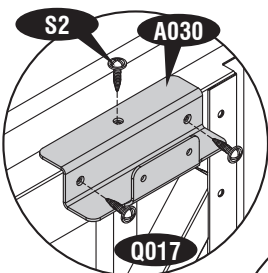

1

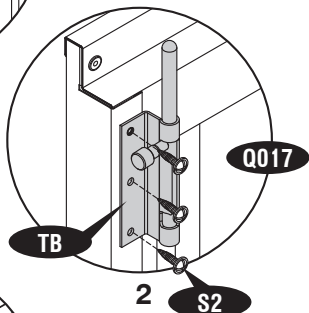

2

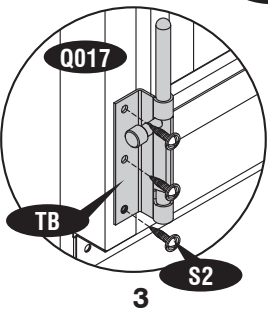

3

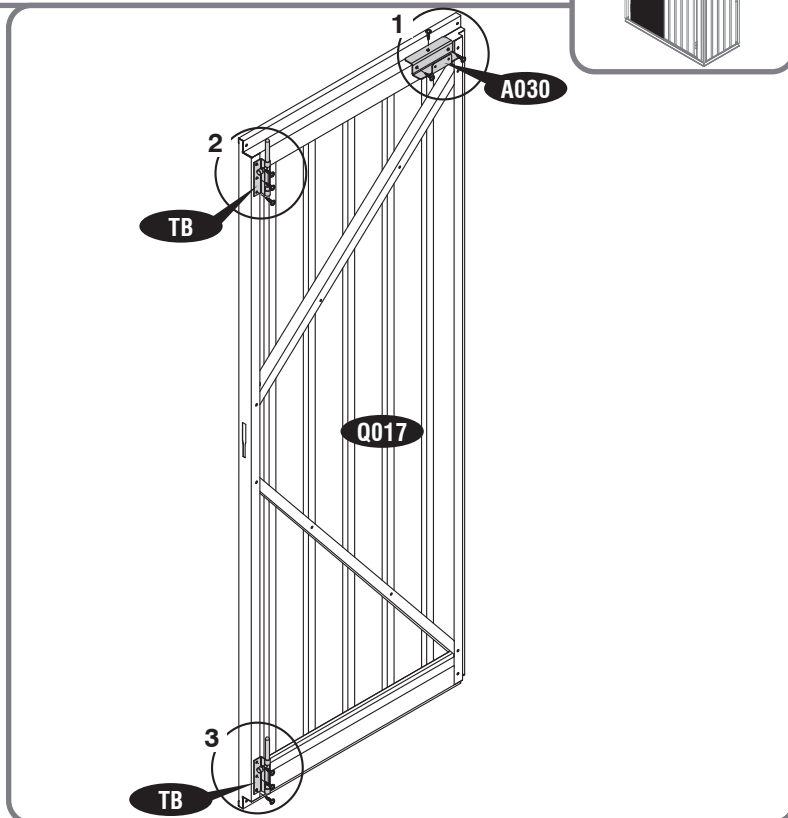

- EN Fully tighten all the bolts & nuts now !  
 FR Serrer tous les boulons & écrous maintenant !  
 DE Alle Schrauben festziehen & Nüssen jetzt!  
 ES Apriete todos los pernos & tuercas ahora!  
 PT Apertar todos os parafusos & doida agora!  
 NL Volledig Draai alle bouten & noten nu!  
 CS Dotáhněte všechny šrouby a matice!  
 SK Plne utiahnite všetky skrutky a matice!  
 SL Popolnoma privijte vse vijake in matice zdaj!  
 HR Sada zategnite sve vijke i matice!  
 HU Teljesen húzza meg az összes csavart és csavaranyát!  
 SV Fullt ut dra åt alla skruvar & nötter nu!  
 IT Serrare tutti i bulloni & dadi ora!  
 PL Dokreć wszystkie śruby & orzechy teraz!  
 RO Strângeți complet toate șuruburile și piulițele acum!  
 BG Напълно затегнете всички болтове и гайки сега!  
 TR Şimdi tüm civata ve somunları tamamen sıkın!

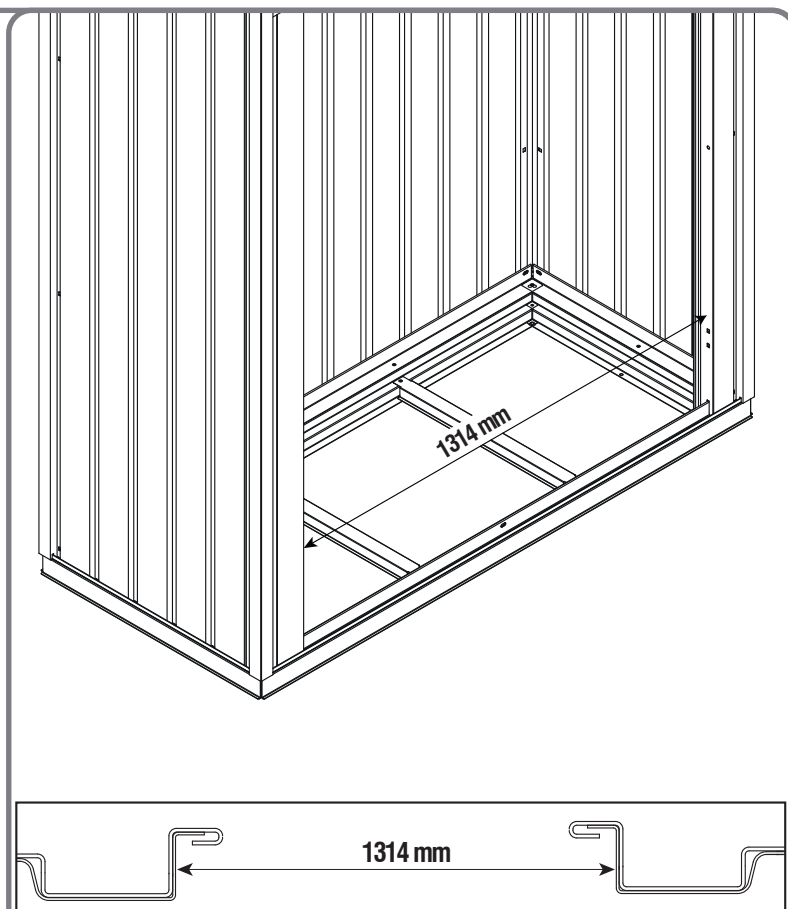

1314 mm

3

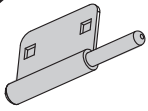

A045 (x1)

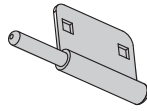

A044 (x1)

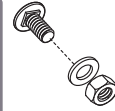

A054 (x4)

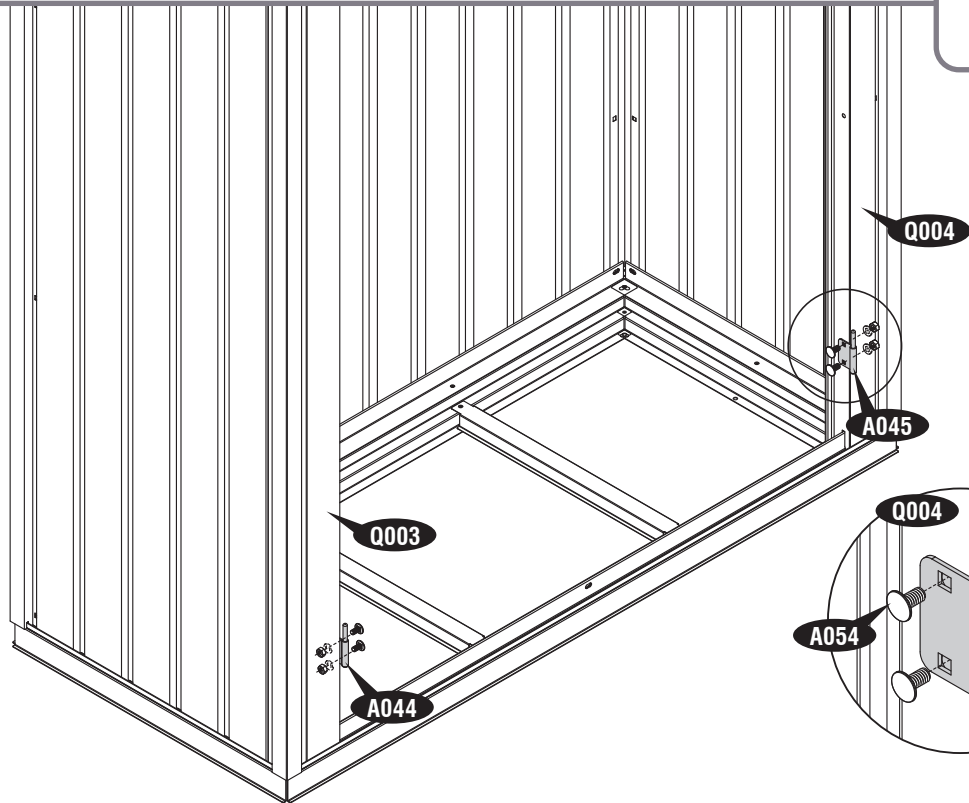

4

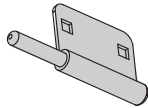

A044 (x1)

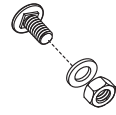

A054 (x2)

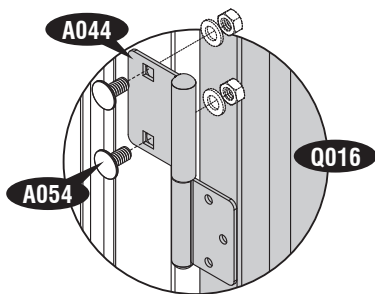

2

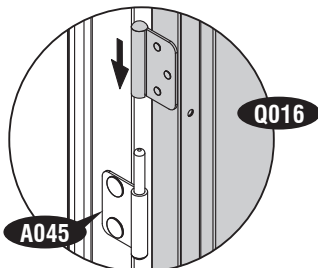

1

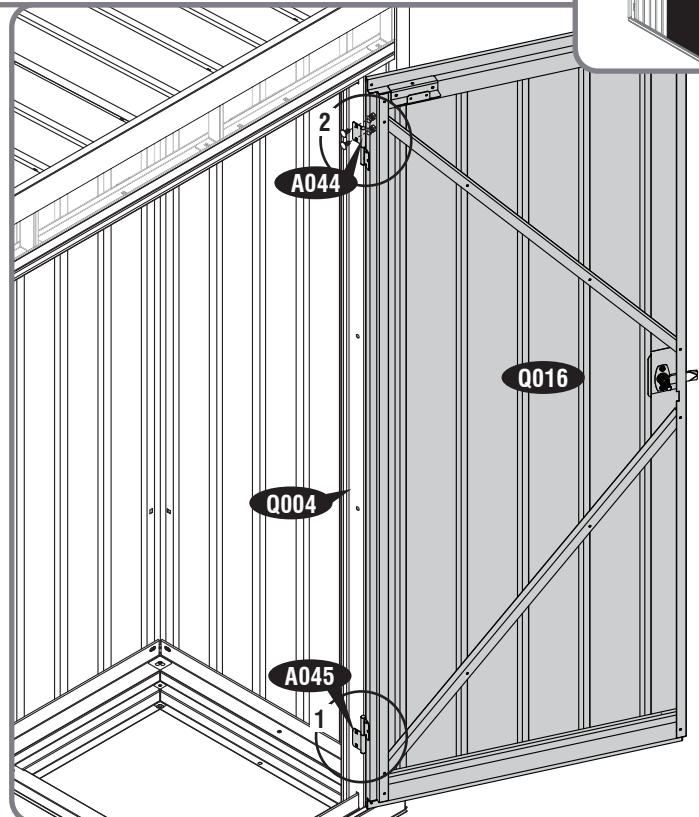



5

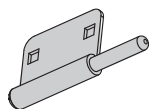

A045 (x1)



A054 (x2)

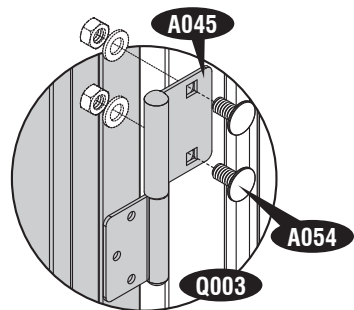

2

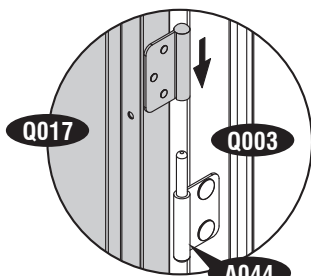

1

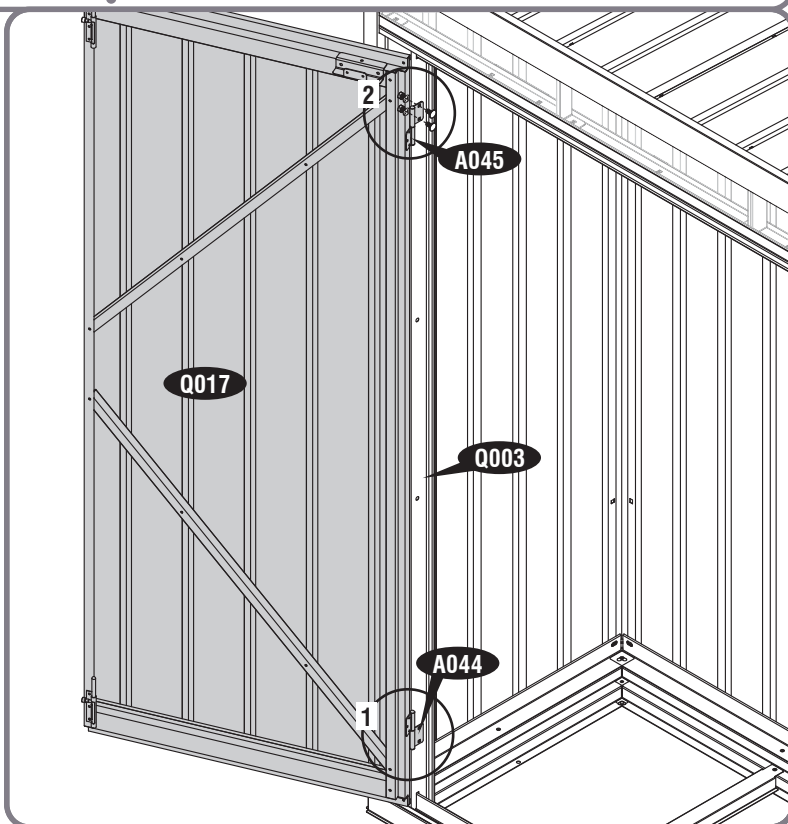

6

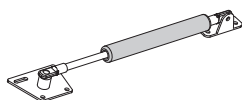

C22M (x2)



S2 (x12)

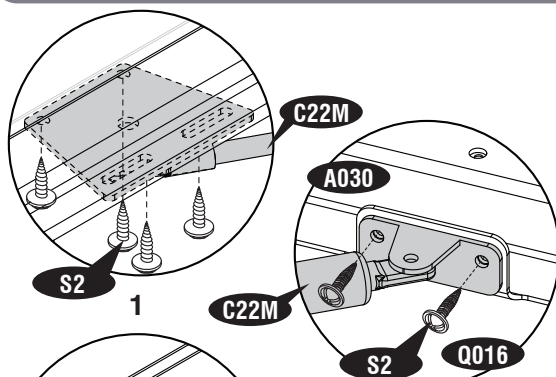
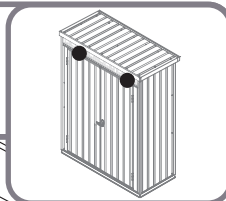

1

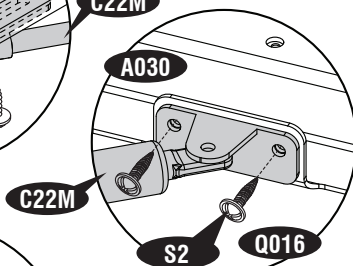

2

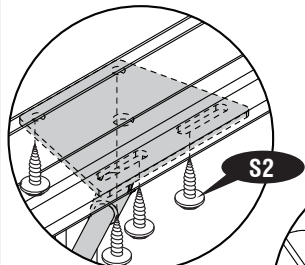

3

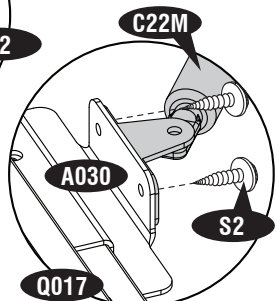

4

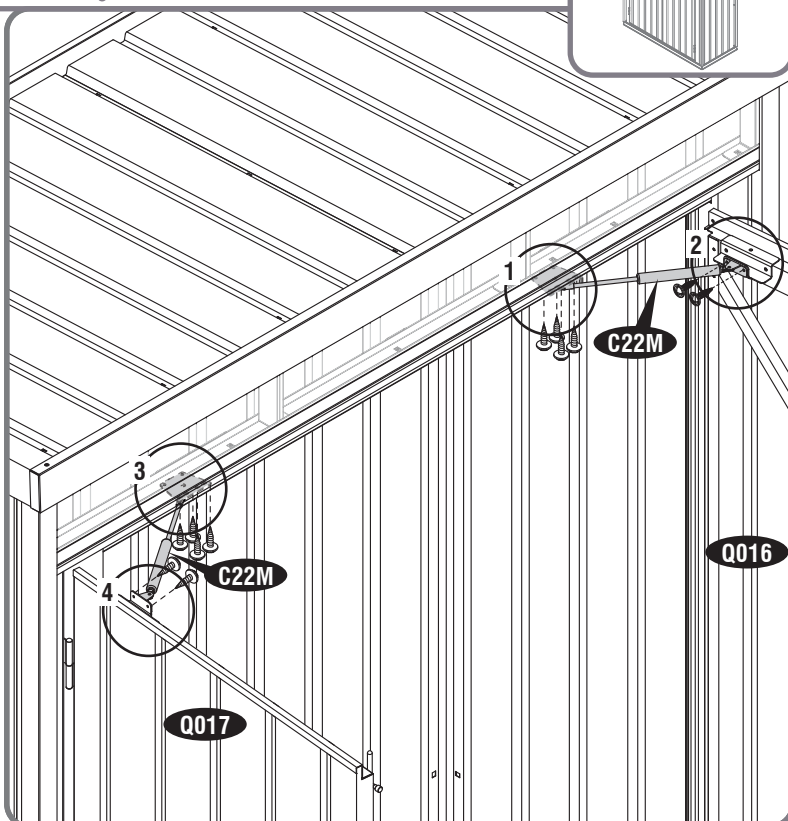

EN Assembly on Concrete Platform	CS Montáž na betonové plošině	IT Montaggio su piattaforma in calcestruzzo
FR Assemblage sur plate-forme en béton	SK Montáž na betónovú plošinu	PL Montaż na betonowej platformie
DE Montage auf Betonplattform	SL Montaža na betonsko ploščad	RO Adunarea pe platforma de beton
ES Montaje sobre la base de hormigón	HR Montaža na betonskoj platformi	BG Монтаж на бетонна платформа
PT Montagem em plataforma de concreto	HU Szerelés beton felületen	TR Beton platform üzerine montaj
NL Montage op betonplatform	SV Montering på betongplattform	



EN Parts needed	CS Potřebné součásti	IT Parti occorrenti
FR Pièces nécessaires	SK Potrebné časti	PL Niezbędne elementy
DE Benötigte Teile	SL Dele, ki jih boste potrebovali	RO Elementele componente necesare
ES Piezas necesitadas	HR Dijelovi potreban	BG Необходими части
PT Peças Necessárias	HU Szükséges részek	TR Gerekli parçalar
NL Onderdelen nodig	SV Delar som behövs	

S8	10
F1	10



- EN** To ensure that your shed withstands high winds, we recommend using this floor option. A concrete pad or large size concrete patio stone squares is recommended for suitable floor base. Make sure it is firm and level and will allow drainage away from the site. Make a level concrete foundation, that has an outside dimension of 64 1/2" x 30" (1640mm x 760mm). **For a concrete pad base, prepare a level bed for a firm footing layer of crushed stone. The concrete pad should then be poured to a thickness of 4 inches (100mm) to 5 inches (125mm). Allow to dry thoroughly for at least 48 hours. Manufacturer is not responsible for the choice and construction of the foundation.**
- FR** Pour vous assurer que votre hangar résiste à des vents violents, nous avons recommandé d'utiliser cette option de plancher. Une dalle de béton ou une grande taille concrètes dalles de patio de est recommandé pour base appropriée au sol. Assurez-vous qu'il est ferme et niveau et permettre un bon drainage du site. Faire niveau fondation en béton, qui a une dimension extérieure de 64 1/2" x 30" (1640mm x 760mm). **Pour une dalle en béton, préparer une couche de graviers de nive au. Le tampon de béton doit ensuite être coulé sur une épaisseur de 4 pouces (100 mm) à 5 pouces (125 mm). Laisser sécher complètement pendant au moins 48 heures. Le fabricant n'est pas responsable du choix et de la construction des fondations.**
- DE** Um sicherzustellen, dass Ihr Schuppen hohen Winden standhält, empfiehlt es sich, diese Bodenoption zu benutzen. Eine konkrete Auflage oder eine große Größe GröÙe konkrete Patio Stein Quadrate wird empfohlen für die geeignete Standring. Stellen Sie sicher, es ist fest und Ebene und Entwässerung von der Website ermöglicht. Machen Sie eine Ebene Betonfundament, die eine externe Dimension von 64 1/2" x 30" (1640mm x 760mm). **für eine konkrete Auflage hat base, einer soliden Basis Schicht aus Schotter ein Niveau Bett vorzubereiten. Die konkrete Auflage sollte dann zu einer Dicke von 4 Zoll (100 mm) bis 5 Zoll (125 mm) gegossen werden. Gründlich mindestens 48 Stunden trocknen lassen. Hersteller ist nicht verantwortlich für die Auswahl und Konstruktion der Stiftung.**
- ES** Para asegurarse de que su cobertizo resiste vientos fuertes, se recomienda utilizar esta opción baja. Un cojín concreto o los cuadrados concretos del tamaño grande de una piedra del patio se recomiendan para la base conveniente para el suelo. Asegúrese de que sea firme y llana y que permita drenaje lejos del sitio. Hacer una fundación nivel concreto que tiene una dimensión fuera de 64 1/2" x 30" (1640mm x 760mm). **Para una base concreta del cojín, prepare una cama llana para una capa de pie firme de la piedra machacada. El cojín concreto se debe entonces verter a un grueso de 4 pulgadas (100mm) a 5 pulgadas (125mm). Permita secarse a fondo por lo menos 48 horas. El fabricante no es responsable de la opción y de la construcción de la fundación.**
- PT** Para garantir que o seu galpão resiste a ventos fortes, recomendamos usar esta opção de andar. Um bloco de concreto ou um quadrados de pedra de pátio de concreto de tamanho grande é recomendado para base apropriado do assoalho. Certifique-se que é firme e nivelada e permitirá drenagem longe do local. Fazer base de uma fundação de concreto nível, que tem uma dimensão exterior de 64 1/2" x 30" (1640mm x 760mm). **Em um bloco de concreto, preparar uma cama de nível para uma camada firme de brita. O base de concreto deve ser derramado em seguida a uma espessura de 4 polegadas (100mm), 5 polegadas (125mm). Deixe para secar completamente pelo menos 48 horas. Fabricante não é responsável pela escolha e construção da Fundação.**
- NL** Om ervoor te zorgen dat uw schuur bestand is tegen hoge winden, raden wij u aan deze vloeroptie te gebruiken. Een concrete pad of een groot formaat concrete patio stenen pleinen wordt aanbevolen voor geschikt woord basis. Zorg ervoor dat het is stevig en niveau en drainage zal toestaan weg van de site. Een niveau concrete stichting, die een externe dimensie van 64 1/2" x 30" (1640mm x 760mm). **For a concrete pad base, prepare a level bed for a firm footing layer of crushed stone. The concrete pad should then be poured to a thickness of 4 inches (100mm) to 5 inches (125mm). Allow to dry thoroughly for at least 48 hours. Manufacturer is not responsible for the choice and construction of the foundation.**
- CS** Abyste zajistili, že váš haly odolává silnému větru, doporučujeme použít tuto podlahu. Pro vhodnou podlahovou základnu se doporučuje betonová podložka nebo velké betonové terasové čtverce. Ujistěte se, že je pevný a rovný a umožní odvodnění od místa. Vyrobtte hladký betonový podklad, který má vnější rozměr 64 1/2" x 30" (1640mm x 760mm). **U betonové podložky připravte rovnou lůžko pro pevnou podkladovou vrstvu drčeného kamene. Betonová vložka by měla být nalita do tloušťky od 100 palců do 5 palců (125 milimetrů). Nechte důkladně vyschnout po dobu nejméně 48 hodin. Výrobce nezodpovídá za volbu a výstavbu nadace.**

**SK** Aby ste zabezpečili, že vaša haly odolá vysokému vetru, odporúčame použiť túto podlahovú možnosť.  
Na vhodnú podlahovú základňu sa odporúča betónová podložka alebo veľké betónové terasové kamenné štvorce. Uistite sa, že je pevný a rovný a umožní odvodnenie z miesta. Vytvorte základovú betónovú základ, ktorý má vonkajší rozmer 64 1/2" x 30"(1640mm x 760mm).  
**Pre betónovú podložku pripravte hladkú vrstvu pre pevnú základovú vrstvu drveného kameňa. Betónová podložka by mala byť potom naliata do hrúbky 4 palce (100 mm) až 5 palcov (125 mm). Nechajte dôkladne vysušiť aspoň 48 hodín. Výrobca nie je zodpovedný za výber a výstavbu nadácie.**

**SL** Da bi zagotovili, da bo vaša hiša odtegnila visoke vetrove, smo priporočili, da uporabite to možnost.  
Za primerne talne podlage je priporočljiva betonska podloga ali betonski trgi z velikimi površinami. Prepričajte se, da je čvrsta in raven ter omogočila drenažo stran od mesta. Izdelajte ravno betonsko podlogo, ki ima zunanjo dimenzijo dimenzij 64 1/2" x 30"(1640mm x 760mm).  
**Za betonsko podlogo pripravite ravno posteljo za trdno podlogo iz drobljenega kamna. Betonsko ploščo je treba nato vliiti do debeline 4 palcev (100 mm) do 5 palcev (125 mm). Pustite, da se temeljito posuši najmanj 48 ur. Proizvajalec ni odgovoren za izbiro in gradnjo temeljev.**

**HR** Da bismo osigurali da vaš prolaz izdrži jak vjetar, preporučujemo da upotrijebite tu podu.  
Za pogodnu podnu bazu preporučuje se betonska podloga ili velike kamene ploče od betona. Pobrinite se da je čvrsta i razina i omogućit će odvod daleko od stranice. Izradite temeljni betonski temelj koji ima vanjsku dimenziju od 64 1/2" x 30"(1640mm x 760mm).  
**Za betonsku podlogu, pripremite krevet na razini za čvrsto podnožje slomljenog kamena. Betonsku podlogu treba zatim izliti na debljinu od 100 mm do 125 inča. Ostavite temeljito suhom najmanje 48 sati. Proizvođač nije odgovoran za odabir i izgradnju zaklade.**

**HU** Annak érdekében, hogy a fészert ellenálljon a magas szeleknek, javasoljuk, hogy használja ezt a padlót.  
Betonpárna vagy nagyméretű betonpadló kőpadok ajánlottak megfelelő padlóalapra. Győződjön meg arról, hogy szilárd és vízszintes, és lehetővé teszi a vízelvezetést távol a helyszíntől. Végezzünk el egy szintetikus alapot, amely 64 1/2" x 30"(1640mm x 760mm).  
**Betonpárnás aljzat esetén készítsen egy szintes ágyat egy szilárd alapozórétegre. A betonpárnát ezután 100 mm-es és 125 mm-es vastagságúra kell önteni. Legalább 48 órán keresztül hagyja alaposan száradni. A gyártó nem vállal felelősséget az alapítvány kiválasztásához és megépítéséért.**

**SV** För att säkerställa att din skjul tål hög vind rekommenderar vi att du använder det här golvalternativet.  
En betongkudde eller en stor betongplattform stenplattor rekommenderas för lämplig golvyta. Se till att den är fast och jämn och gör det möjligt att dränera bort från platsen. Gör en jämn betongfundament, som har en yttre dimension av 64 1/2" x 30"(1640mm x 760mm).  
**För en betongplatta bas, förbereda en nivå säng för ett fast fotskikt av krossad sten. Betongplattan ska sedan hållas till en tjocklek av 4 tum (100 mm) till 5 tum (125 mm). Låt torka noggrant i minst 48 timmar. Tillverkaren ansvarar inte för valet och byggandet av stiftelsen.**

**IT** Per garantire che il tuo capannone sopporta venti elevati, abbiamo consigliato di utilizzare questa opzione a pavimento.  
Si consiglia un tappetino in calcestruzzo o un quadrato in pietra di cemento in grande formato per una base adatta. Assicurarsi che sia stabile e livellato e permetterebbe di drenare lontano dal sito. Realizzare una base di calcestruzzo di livello, che ha una dimensione esterna di 64 1/2" x 30"(1640mm x 760mm).  
**Per una base di rilievo in calcestruzzo, preparare un letto a livello per un solido strato di pietra schiacciata. Il tappetino di calcestruzzo deve quindi essere versato ad uno spessore da 100 mm a 125 centimetri. Lasciare asciugare accuratamente per almeno 48 ore. Il produttore non è responsabile della scelta e della costruzione della fondazione.**

**PL** W celu zapewnienia, że szopy wytrzymują wysokie wiatry, zalecamy skorzystanie z tej opcji podłogi.  
Betonu pad lub duży rozmiar konkretne patio kamień kwadratów jest zalecane dla odpowiedniej bazy pietra. Upewnij się, że to jest prosto i stabilnie i pozwoli drenaż witrny. Zrobić fundamentie betonowym poziom, który ma wymiar zewnętrzny 64 1/2" x 30"(1640mm x 760mm).  
**Do betonu pad podstawy, przygotować łóżko poziom dla firmy stopie warstwę tłucznia. Betonu pad powinien być następnie przelewa się do grubości 4 cali (100mm) do 5 cali (125mm). Pozostawić do wyschnięcia dokładnie na co najmniej 48 godzin. Producent nie jest odpowiedzialny za wybór i budowie fundamentów.**

**RO** Pentru a vă asigura că vaporul dvs. rezistă unor vânturi puternice, am recomandat să folosiți această opțiune pentru podea.  
Un tampon de beton sau o pătrată de piatră din beton de dimensiuni mari este recomandată pentru o bază adecvată pentru podea. Asigurați-vă că este ferm și la nivel și va permite scurgerea departe de site. Asigurați o fundație de beton de nivel, care are o dimensiune exterioară de 64 1/2" x 30"(1640mm x 760mm).  
**Pentru o bază de bază de beton, pregătiți un pat de nivel pentru un strat ferm de piatră zdrobită. Plăcuța de beton trebuie apoi turnată la o grosime de 4 inci (100 mm) până la 5 inci (125 mm). Lăsați-l să se usuce bine timp de cel puțin 48 de ore. Producătorul nu este responsabil pentru alegerea și construirea fundației.**

**BG** За да сте сигурни, че Вашата барака издържа високи ветрове, препоръчваме да използвате тази опция за пода.  
За подходяща подова основа се препоръчва използването на бетонна подложка или големи бетонни квадратни плочки. Уверете се, че тя е здрава и равна и ще позволи дренаж далеч от мястото. Направете нивелирана бетонна основа, която има външен размер от 64 1/2" x 30"(1640mm x 760mm).  
**За бетон основа на подложка, подгответе ниво легло за твърда основа слой от натрошен камък. След това бетонната подложка трябва да се излива на дебелина от 4 инча (100 mm) до 5 инча (125 mm). Оставете да изсъхне напълно за поне 48 часа. Производителят не носи отговорност за избора и изграждането на основата.**

**TR** Sunduğunuzdan yüksek rüzgarlara dayanıklı olmasını sağlamak için bu zemin seçeneğini kullanmanızı öneririz.  
Uygun taban tabanı için beton bir yastık veya büyük boy bir beton bahçe avlusu karosu önerilir. Sert ve sağlam olduğundan ve drenajın yerinden uzaklaşmasına izin vereceğinden emin olun. Basic Shed için dış boyut 64 1/2" x 30"(1640mm x 760mm).  
**Beton pad taban için, ezilmiş taştan sağlam bir taban tabakası için düz bir yatak hazırlayın. Beton pedi daha sonra 4 inç (100mm) ile 5 inç (125mm) arasındaki bir kalınlığa dökülmelidir. En az 48 saat boyunca iyice kurummasına izin verin. Üretici, vakfın seçimi ve yapımı için sorumlu değildir.**





F1 (x10)



S8 (x10)

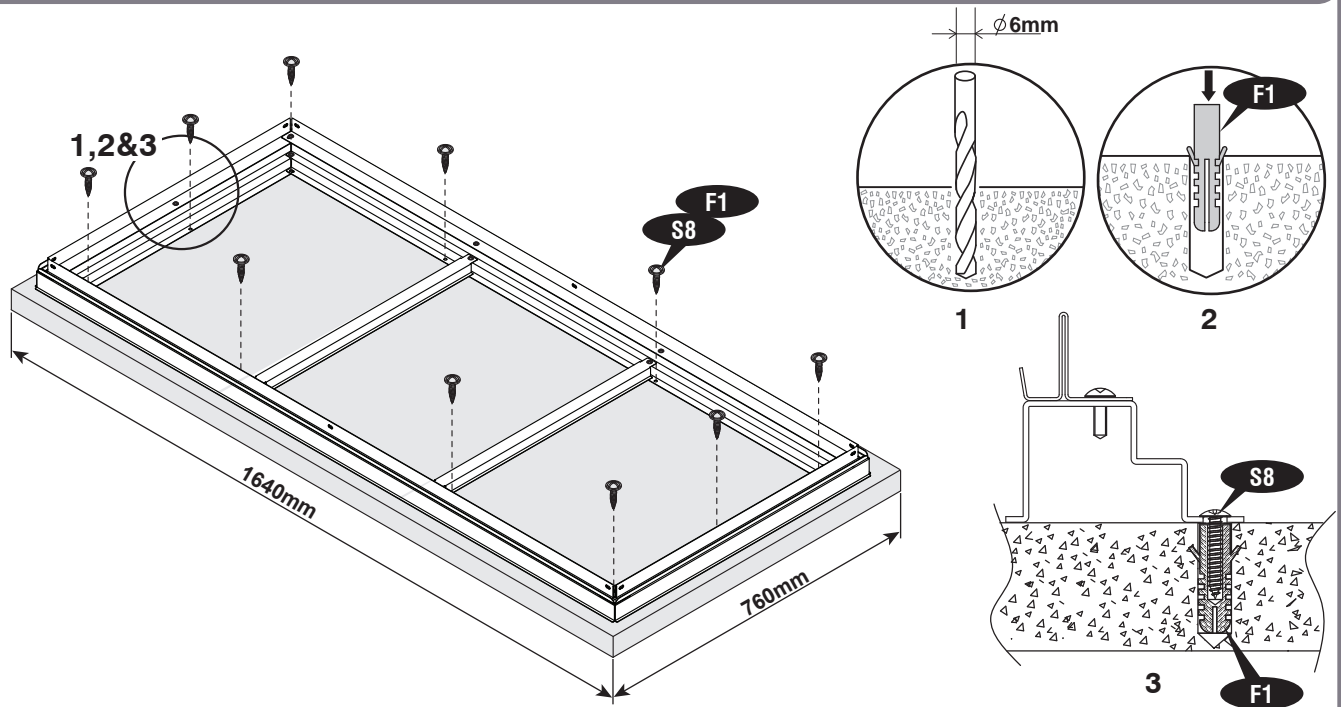

EN Floor Options

FR Option plancher

DE Bodenoptionen

ES Opción de piso

PT Opções de piso

NL Betonnen plaat

CS Možnosti podlahy

SK Možnosti podlahové

SL Možnosti tal

HR Kat Mogućnosti

HU Padlóbeállítások

SV Golvalternativ

IT Opzioni del pavimento

PL Opcje podłogowe

RO Opțiuni de podea

BG Подови опции

TR Yer Seçenekleri

EN Plywood (Not included)

FR Contreplaqué (non inclus)

DE Sperrholz (Nicht enthalten)

1

ES Contrachapado (No incluido)

PT Contraplacado (não incluído)

NL Multiplex (niet inbegrepen)

CS Překlíčka (není součástí balení)

SK Preglejka (nie je súčasťou balenia)

SL Vezane plošče (niso vključene)

HR Šperploča (nije uključeno)

HU Rétegelt lemez (nem tartozék)

SV Plywood (ingår ej)

IT Compensato (non incluso)

PL Sklejka (nie wliczone)

RO Placaj (Nu este inclus)

BG Шперплат (не е включен)

TR Kontrplak (dahil değildir)

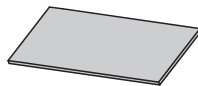

58 3/8" x 23 5/8" X 3/4" (x2)  
[1482mm x 600mm x 19mm (x2)]



EN Place the Exterior Grade (CDX) - 3/4" (19mm) Weather proof Marine grade plywood on top of the foundation.

FR Placer le grade extérieur (CDX) -3/4 "(19mm) résistante aux intempéries de contreplaqué de qualité marine au-dessus de la fondation.

DE Legen Sie das wetterbeständige Marine Grade Sperrholz (CDX) -3/4"(19 mm) auf die Oberseite des Fundaments.

ES Coloque el grado exterior (CDX) -3/4 "(19 mm) resistente a la intemperie contrachapado marino de grado en la parte superior de la fundación.

PT Coloque o Exterior Grau (CDX) - 3/4 "(19mm) Contraplacado marítimo à prova de intempéries no topo da fundação.

- NL** Place the Exterior Grade (CDX) - 3/4" (19mm) Weather proof Marine grade plywood on top of the foundation.
- CS** Umístěte vnější použití (CDX) - 3/4" (19 mm), odolná vůči povětrnostním vlivům mořské stupeň překližky na vrcholu základu.
- SK** Umiestnite vonkajšie použitie (CDX) - 3/4 "(19 mm), odolná voči poveternostným vplyvom morskej stupeň preglejky na vrchole základu.
- SL** Postavite Zunanjost razred (CDX) - 3/4 "(19mm) Vreme dokaz Marine stopnje vezan na vrhu temelja.
- HR** Postavite vanjsku površinu (CDX) - 3/4 "(19 mm) morsku ploču s obloženom vremenskom zaštitom na vrhu temelja.
- HU** Helyezzük el a külső minőséű (CDX) - 3/4 "(19 mm) időjárásálló minőséű tengeri rétegelt lemezt az alapzat tetején.
- SV** Placera yttre graden (CDX) - 3/4 "(19mm) Vädret bevis Marine grade plywood ovanpå fundamentet.
- IT** Collocare il compensato di grado marino per esterni (CDX) - 3/4 "(19mm) sopra la fondazione.
- PL** Umieść wodoodporną sklejkę klasy morskiej (CDX) - 3/4 "(19 mm) odporną na warunki atmosferyczne na fundamentcie
- RO** Așezați placa de calitate exterioară (CDX) - placaj de calitate maritimă de 3/4 "(19mm) pe fundul fundației.
- BG** Поставете външния клас (CDX) - 3/4 "(19 мм) Влагоустойчив шперплат от морски клас върху основата.
- TR** Dış Tabanı (CDX) - 3/4 "(19mm) Hava şartlarına dayanıklı Deniz sınıfı kontrplakı, temelın üstüne yerleştirin.

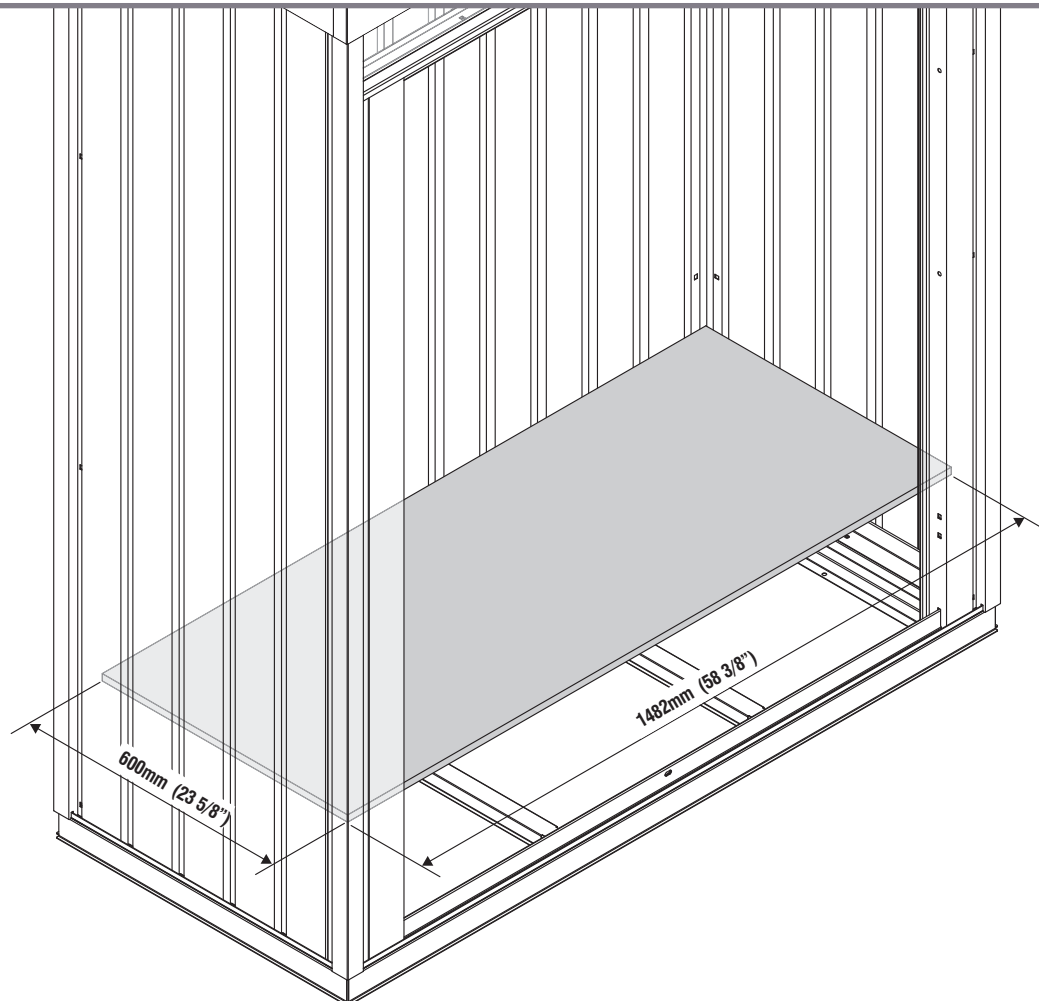

- |                                     |   |                                       |
|-------------------------------------|---|---------------------------------------|
| EN Concrete Floor (Not included)    | CS Betonová podlaha (není součástí balení)    | IT Pavimento in cemento (non incluso) |
| FR Plancher de béton (non inclus)   | SK Betónová podlaha (nie je súčasťou balenia) | PL Podłoga betonowa (nie wliczone)    |
| DE Betonboden (Nicht enthalten)     | SL Betonska tla (niso vključene)              | RO Podea din beton (nu este inclusă)  |
| ES Piso de concreto (No incluido)   | HR Betonski kat (nije uključen)               | BG Бетонни подове (не са включени)    |
| PT Piso de concreto (não incluído)  | HU Betonpadló (nem tartozék)                  | TR Beton Zemin (dahil değildir)       |
| NL Betonnen vloer (niet inbegrepen) | SV BetonggolV (ingår ej)                      |                                       |

2

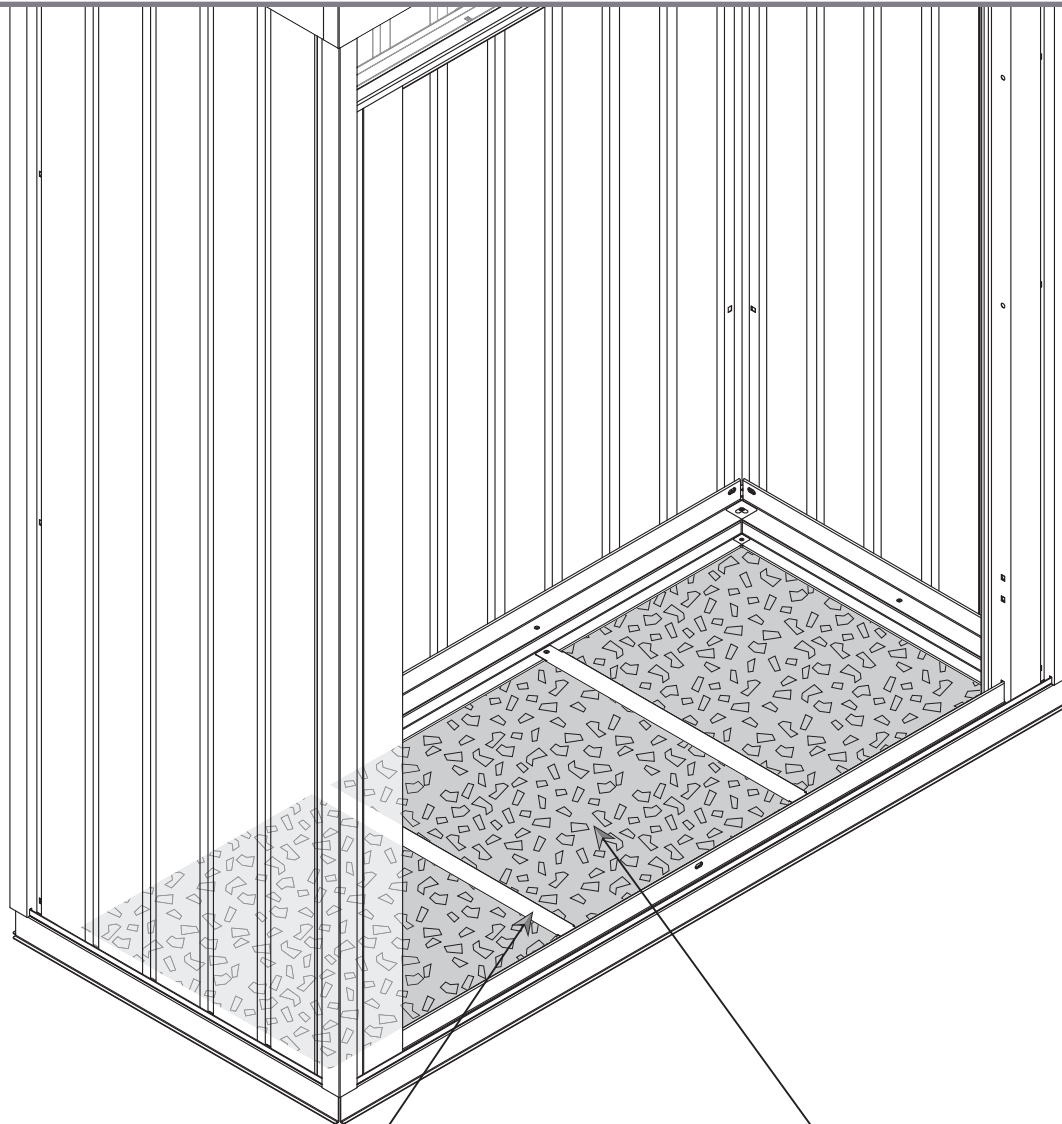

(EN) Concrete to be filled up to this level  
 (FR) Béton à remplir à ce niveau  
 (DE) Beton, der bis zu dieser Ebene gefüllt werden muss  
 (ES) Concreto para ser llenado hasta este nivel  
 (PT) Concreto a ser preenchido até este nível  
 (NL) Beton dat tot dit niveau moet worden opgevuld  
 (CS) Beton, který se má naplnit do této úrovně  
 (SK) Betón, ktorý sa má naplniť do tejto úrovne  
 (SL) Beton, ki ga je treba napolniti do te stopnje  
 (HR) Beton koji treba popuniti na ovu razinu  
 (HU) Beton kell tölteni ezt a szintet  
 (SV) Betong fylls upp till denna nivå  
 (IT) Calcestruzzo da riempire fino a questo livello  
 (PL) Beton do wypełnienia do tego poziomu  
 (RO) Beton care trebuie umplut până la acest nivel  
 (BG) Бетонът трябва да се запълни до това ниво  
 (TR) Bu seviyeye kadar doldurulacak beton

(EN) Concrete  
 (FR) Béton  
 (DE) Beton  
 (ES) Hormigón  
 (PT) Concreto  
 (NL) Beton  
 (CS) Beton  
 (SK) Beton  
 (SL) Beton  
 (HR) Beton  
 (HU) Konkrét  
 (SV) Betong  
 (IT) Calcestruzzo  
 (PL) Beton  
 (RO) Beton  
 (BG) бетон  
 (TR) Beton

7

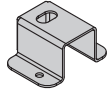

Q032 (x1)



S2 (x2)

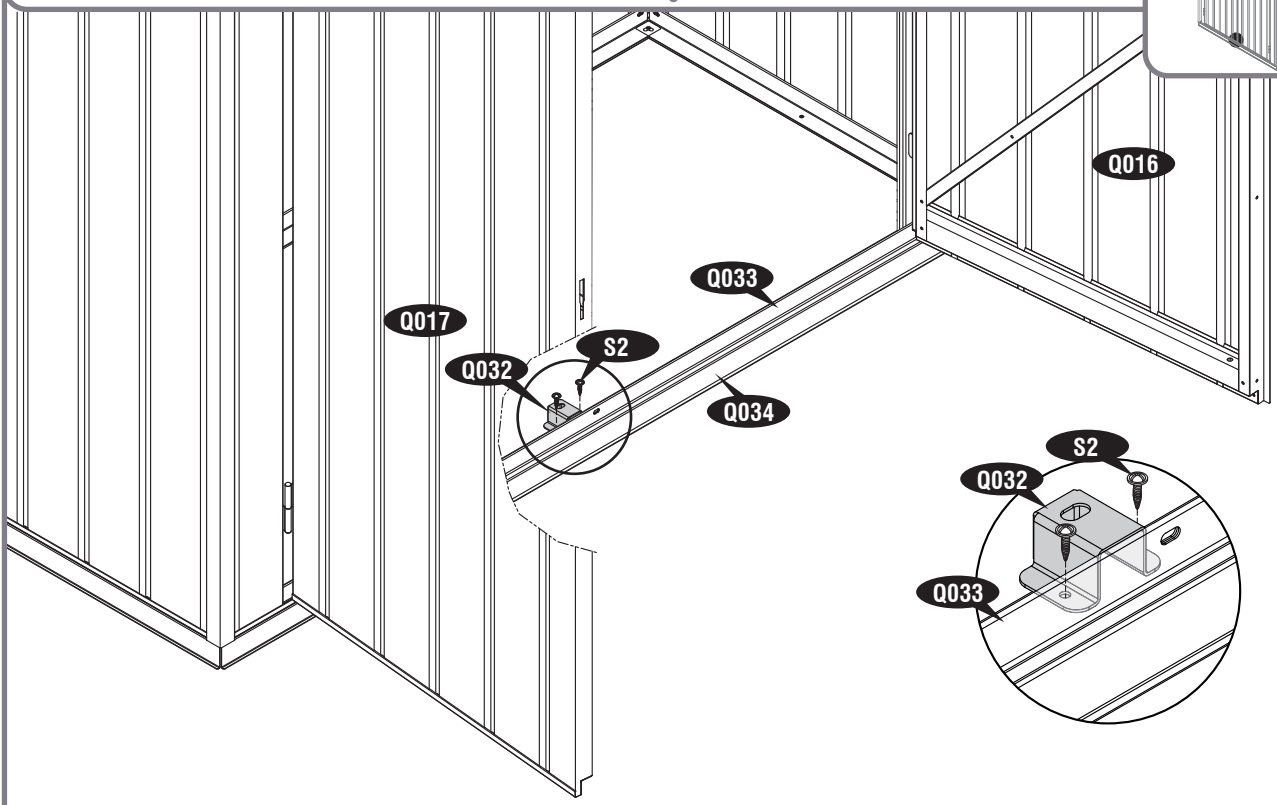

8



A048 (x1)



A049 (x1)



A050 (x1)

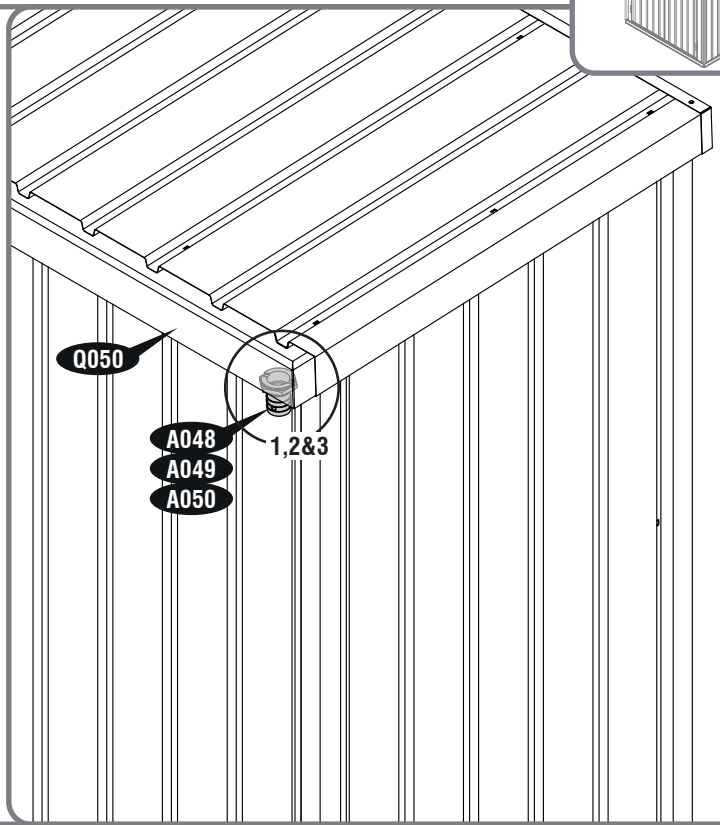
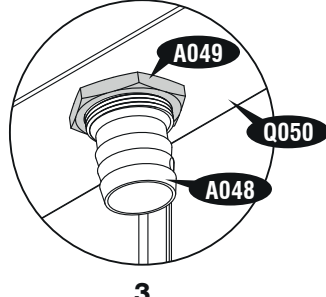
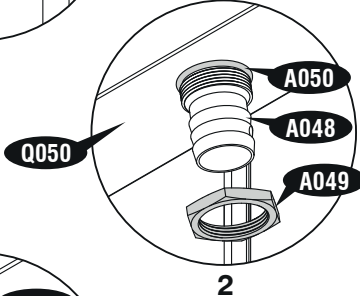
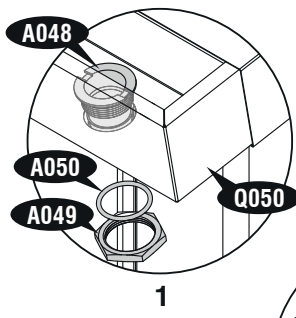



## A053

- (EN) Fix the plastic screw cover (A053) to the screws and bolts edge from inside to prevent injury.
- (FR) Fixer le couvercle à vis en plastique (A053) à la pointe de vis et de boulons à l'intérieur pour prévenir les accidents.
- (DE) Befestigen Sie die Kunststoffschraubenbedeckung (A053) an das Ende der Schrauben und Bolzen von innen, um Verletzungen zu verhindern.
- (ES) Ponga los tornillos de plástico (A053) desde el interior de la caseta para prevenir heridas.
- (PT) Fixar as coberturas plásticas (A053) em todos os parafusos e porcas para prevenir lesões.
- (NL) Op de plastic schroefdoppen (A053) op de schroeven en bouten om verwondingen te vermijden.
- (CS) Nasadte plastové kryti šroubu(A053), aby zabránit případným zraněním.
- (SK) Položte umelé kryty na skrutky (A053) a šraubky z vnútornej strany, aby ste predišli úrazu.
- (SL) Pritrdite plastične pokrove za vijake (A053) na vijake in robove sornikov z notranje strani, da preprečite telesne poškodbe.
- (HR) Popravite plastični poklopac vijak (A053) do vijaka i matica rub od unutra za sprječio ozljede.
- (HU) Helyezze fel a (A053) műanyag csavarfedeleket a csavarokra belülről, a sérülések elkerülése érdekében.
- (SV) Sätt fast plastskruvskyddet (A053) på skruvarna och bultändarna från insidan för att förebygga skada.
- (IT) Fissa la copertura per le viti in plastica (A053) alle viti e alle estremità dei bulloni per prevenire danni e ferite.
- (PL) Aby zapobiec zranieniu, zainstaluj plastikowe nakrętki (A053) na końce śrub i wkrętów od wewnątrz.
- (RO) Fixați protecția de plastic a șuruburilor (A053) pe marginea șuruburilor și bolțurilor din interior pentru a preveni accidentarea.
- (BG) Завийте пластмасовите капачки, скриващи винтовете (A053) до краищата на болтовете и винтовете от вътрешната страна, за да избегнете наранявания.
- (TR) Herhangi bir kazayı önlemek için, plastik kapağı (A053) içeriden vida ve pulların köşelerine sabitleyiniz.

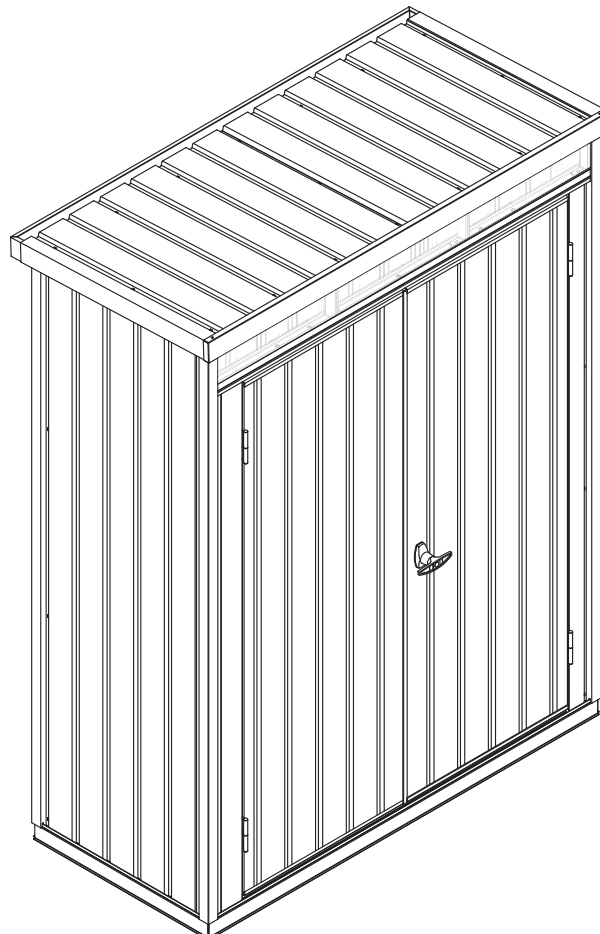
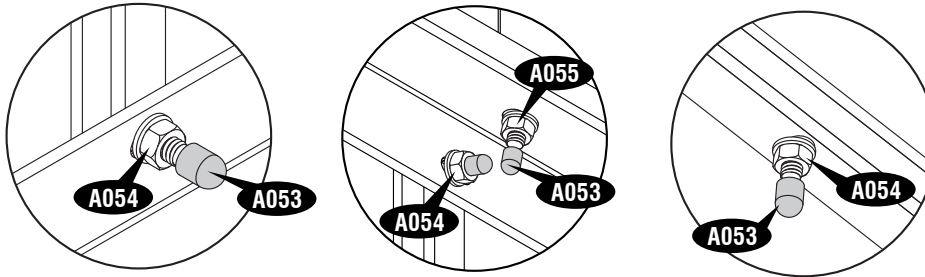





6

- |               |           |            |
|---------------|-----------|------------|
| EN Shelf      | CS Regál  | IT Mensola |
| FR Étagère    | SK Šelf   | PL Półka   |
| DE Regal      | SL Polica | RO Poliță  |
| ES Estante    | HR Raf    | BG Рафт    |
| PT Prateleira | HU Polc   | TR Raf     |
| NL Plank      | SV Hylla  |            |

- |                       |                                   |                                   |
|-----------------------|-----------------------------------|-----------------------------------|
| EN Parts needed       | CS Potřebné součásti              | IT Parti occorrenti               |
| FR Pièces nécessaires | SK Potřebné části                 | PL Niezbędne elementy             |
| DE Benötigte Teile    | SL Dele, ki jih boste potrebovali | RO Elementele componente necesare |
| ES Piezas necesitadas | HR Dijelovi potreban              | BG Необходими части               |
| PT Peças Necessárias  | HU Szükséges részek               | TR Gereklî parçalar               |
| NL Onderdelen nodig   | SV Delar som behövs               |                                   |

C002	2
C004	4
C006	2
S2	4

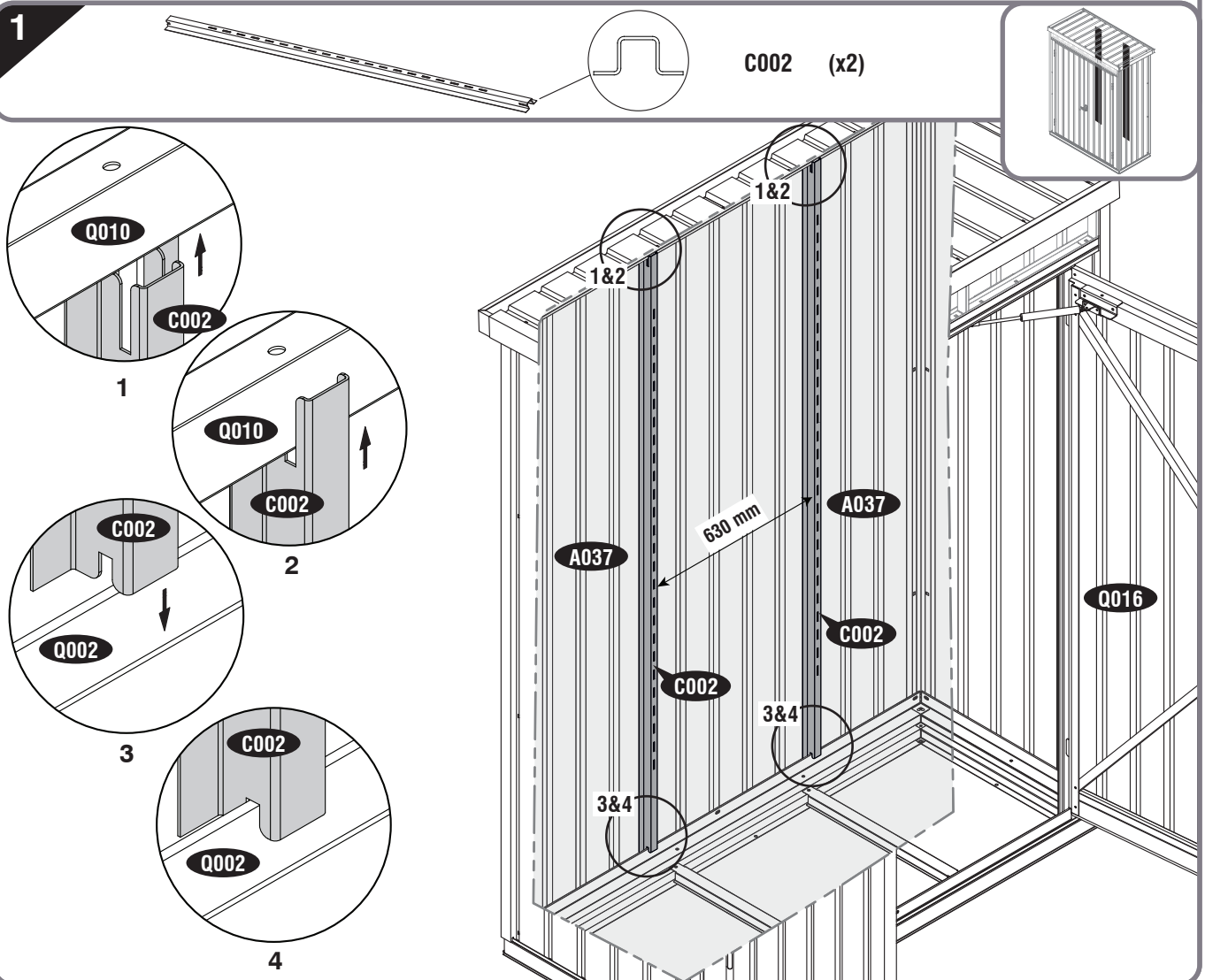

2

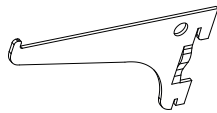

C004 (x4)

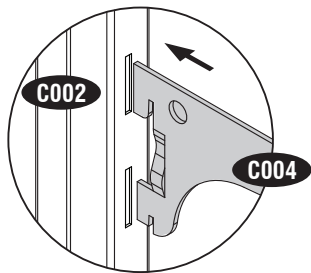
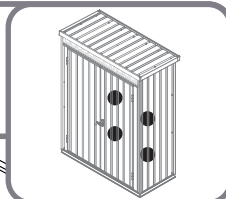

1

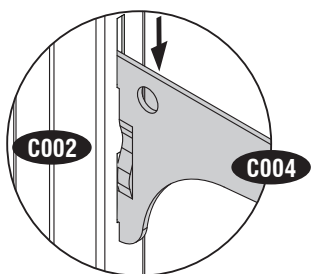

2

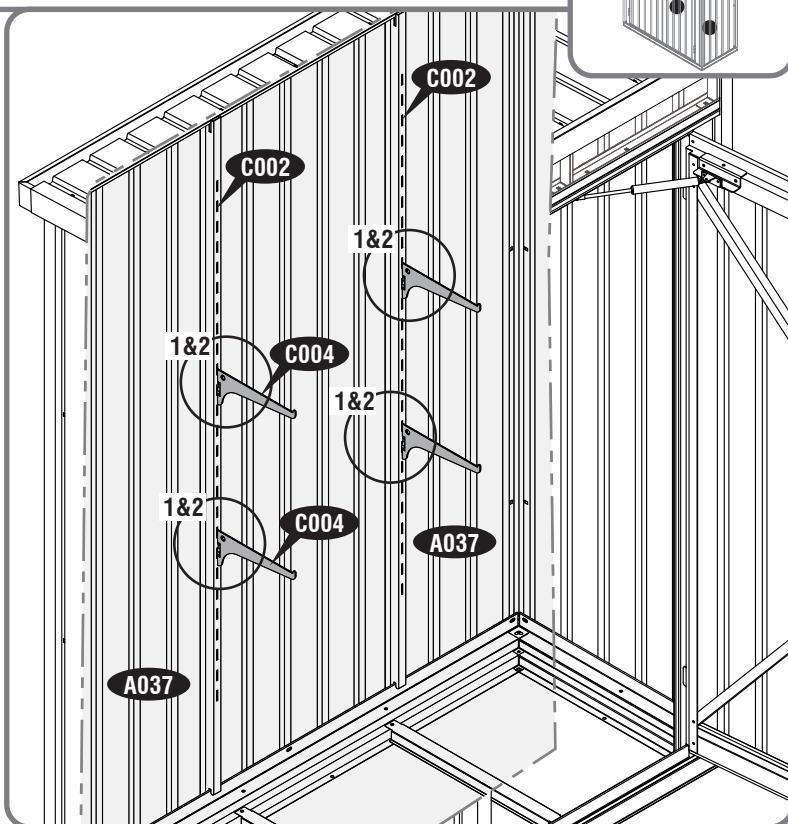

3



C006 (x2)



S2 (x4)

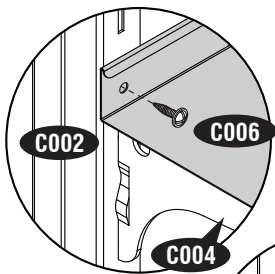
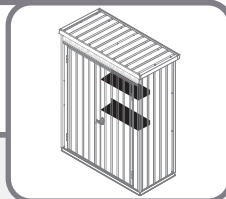

1

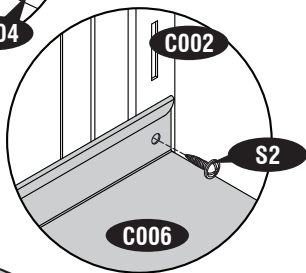

2

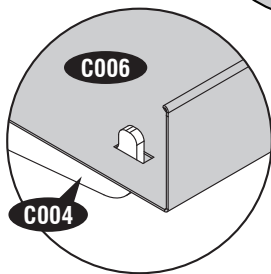

3

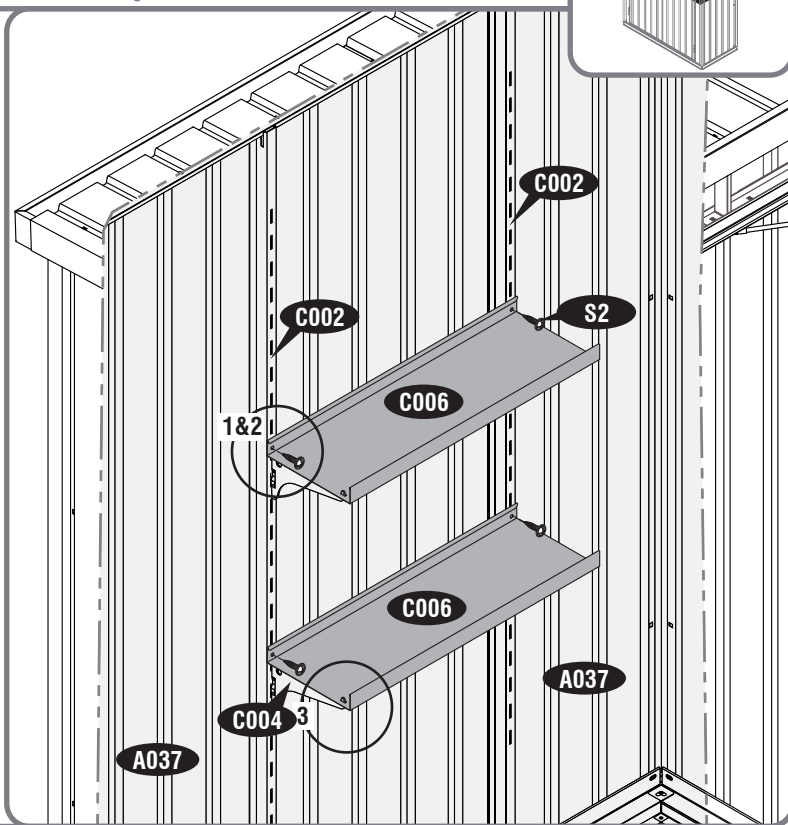





U.S. Polymers, Inc.  
1057 S. Vail Ave  
Montebello, CA 90640,  
United States of America

[www.duramaxbp.com](http://www.duramaxbp.com)